

APPENDIX I

Noise Study

NOISE STUDY

Cypress Point 54 Unit Residential Development City of Oceanside, CA

Prepared By:

Ldn Consulting, Inc.
42428 Chisolm Trail
Murrieta, California 92562
760-473-1253

Prepared For:

**Concordia Homes
380 Stevens Avenue, Suite 307
Solana Beach, CA 92075**

August 17, 2021

TABLE OF CONTENTS

TABLE OF CONTENTS	II
LIST OF FIGURES	III
LIST OF TABLES	III
GLOSSARY OF COMMON TERMS	IV
EXECUTIVE SUMMARY	V
1.0 PROJECT INTRODUCTION	2
1.1 PURPOSE OF THIS STUDY	2
1.2 PROJECT LOCATION	2
1.3 PROJECT DESCRIPTION	2
2.0 ACOUSTICAL FUNDAMENTALS	5
3.0 SIGNIFICANCE THRESHOLDS AND STANDARDS	7
3.1 TRANSPORTATION RELATED NOISE	7
3.2 CONSTRUCTION NOISE AND VIBRATION	7
3.3 OPERATIONAL NOISE	9
4.0 NOISE ENVIRONMENT	10
4.1 EXISTING NOISE ENVIRONMENT ONSITE	10
4.2 ONSITE ROADWAY NOISE	13
4.3 OFFSITE PROJECT RELATED TRANSPORTATION NOISE LEVELS	14
4.4 POTENTIAL OPERATIONAL NOISE IMPACTS (NON-CONSTRUCTION NOISE)	15
5.0 CONSTRUCTION NOISE LEVELS	18
5.1 POTENTIAL CONSTRUCTION NOISE IMPACT	18
5.2 CONSTRUCTION NOISE CONCLUSIONS	20
5.3 CONSTRUCTION VIBRATION FINDINGS	20
5.4 VIBRATION FINDINGS	21
6.0 CERTIFICATIONS	22

LIST OF FIGURES

FIGURE 1-A: PROJECT VICINITY MAP	3
FIGURE 1-B: PROPOSED PROJECT SITE PLAN	4
FIGURE 4-A: AMBIENT NOISE MONITORING LOCATION	11
FIGURE 4-B: OCEANSIDE MUNICIPAL AIRPORT NOISE CONTOURS/PROJECT LOCATION	12
FIGURE 4-C: FUTURE NOISE LEVELS	14
FIGURE 4-D: LOCATIONS OF THE PROPOSED HVAC UNITS	16

LIST OF TABLES

TABLE 3-1: GROUNDBORNE VIBRATION AND NOISE IMPACT CRITERIA (HUMAN ANNOYANCE)	8
TABLE 3-2: GROUNDBORNE VIBRATION IMPACT CRITERIA (STRUCTURAL DAMAGE)	8
TABLE 3-3: SOUND LEVEL LIMITS	9
TABLE 4-1: MEASURED AMBIENT NOISE LEVELS	10
TABLE 4-2: TRAFFIC PARAMETERS	13
TABLE 4-3: PROJECT HVAC NOISE LEVELS (NEAREST PROPERTY LINE)	17
TABLE 5-1: CONSTRUCTION NOISE LEVELS.....	19
TABLE 5-2: VIBRATION LEVELS FROM CONSTRUCTION ACTIVITIES (RESIDENTIAL RECEPTORS).....	20

ATTACHMENTS

HVAC NOISE LEVELS AND SPECIFICATIONS	23
FRESNEL BARRIER REDUCTION CALCULATIONS	33

GLOSSARY OF COMMON TERMS

Sound Pressure Level (SPL): a ratio of one sound pressure to a reference pressure (L_{ref}) of 20 μ Pa. Because of the dynamic range of the human ear, the ratio is calculated logarithmically by $20 \log (L/L_{ref})$.

A-weighted Sound Pressure Level (dBA): Some frequencies of noise are more noticeable than others. To compensate for this fact, different sound frequencies are weighted more.

Minimum Sound Level (L_{min}): Minimum SPL or the lowest SPL measured over the time interval using the A-weighted network and slow time weighting.

Maximum Sound Level (L_{max}): Maximum SPL or the highest SPL measured over the time interval the A-weighted network and slow time weighting.

Equivalent sound level (L_{eq}): the true equivalent sound level measured over the run time. L_{eq} is the A-weighted steady sound level that contains the same total acoustical energy as the actual fluctuating sound level.

Day Night Sound Level (LDN): Representing the Day/Night sound level, this measurement is a 24 –hour average sound level where 10 dB is added to all the readings that occur between 10 pm and 7 am. This is primarily used in community noise regulations where there is a 10 dB “Penalty” for nighttime noise. Typically, LDN’s are measured using A weighting.

Community Noise Exposure Level (CNEL): The accumulated exposure to sound measured in a 24-hour sampling interval and artificially boosted during certain hours. For CNEL, samples taken between 7 pm and 10 pm are boosted by 5 dB; samples taken between 10 pm and 7 am are boosted by 10 dB.

Octave Band: An octave band is defined as a frequency band whose upper band-edge frequency is twice the lower band frequency.

Third-Octave Band: A third-octave band is defined as a frequency band whose upper band-edge frequency is 1.26 times the lower band frequency.

Response Time (F,S,I): The response time is a standardized exponential time weighting of the input signal according to fast (F), slow (S) or impulse (I) time response relationships. Time response can be described with a time constant. The time constants for fast, slow and impulse responses are 1.0 seconds, 0.125 seconds and 0.35 milliseconds, respectively.

EXECUTIVE SUMMARY

This noise study has been completed to determine the noise impacts to and from the development of the proposed 54-unit single family development. The proposed Project site is located at the terminus of Pala Road and Los Arbolitos Boulevard in the City of Oceanside. The project site including the area necessary to complete the roadway alignments adjacent to the site is roughly 7.3 acres.

Transportation Noise Levels – Onsite

Based upon the findings of the Buildout analysis, exterior noise from vehicular traffic onto the Project will be in compliance with the City of Oceanside's Noise Element and no impacts are anticipated at the outdoor usable areas and no mitigation measures are required. The proposed project is near the Oceanside Municipal Airport areas but is not within any of the noise contours due to infrequent aircraft over flights and therefore no mitigation to any structures or sensitive land uses is necessary due to aircraft.

The City of Oceanside as part of its noise guidelines also states, consistent with Title 24 of the California Code of Regulations (CCR), a project is required to perform an interior assessment on the portions of a project site where building façade noise levels are above 60 dBA CNEL in order to ensure a 45 dBA CNEL interior noise level. An interior noise assessment is required for the residential units along the roadways prior to the issuance of the first building permit once the architectural floor plans are available. This final report would identify the interior noise requirements to meet the City's established interior noise limit of 45 dBA CNEL.

Offsite Project Related Transportation Noise Levels

The Project does not create a direct noise increase of more than 3 dBA CNEL on any roadway segment. Therefore, the project's direct contributions to off-site roadway noise increases will not cause any significant impacts to any existing or future noise sensitive land uses. Therefore, the Project's contributions to off-site roadway noise increase would not be considered cumulatively considerable and would not cause any significant impacts.

Construction Noise Levels

None of the proposed equipment will exceed the City of Oceanside 85 dBA standard at 100 feet from the source. The project will also meet the County of San Diego 75 dBA Leq standard on all proposed equipment and no impacts are anticipated. Accordingly, impacts will be less than significant and no mitigation measures are required.

Operational Noise

Based upon the property line noise levels determined for the Project none of the proposed noise sources directly or cumulatively exceeds the property line standards at the residential property lines. Therefore, the proposed development related operational noise levels comply with the City's daytime noise standards at surrounding residences. No impacts are anticipated and no mitigation is required.

1.0 PROJECT INTRODUCTION

1.1 Purpose of this Study

The purpose of this Noise study is to determine noise impacts, if any, to the Project from off-site sources (i.e., vehicular traffic along adjacent roadways) and impacts from the Project operations (i.e., traffic generated from Project). Should impacts be determined, the intent of this study would be to recommend suitable mitigation measures to reduce impacts to below a level of significance.

1.2 Project Location

The proposed project is located just north at the terminus of Pala Road and is located west of Los Arbolitos boulevard in the City of Oceanside. A general project vicinity map is shown in Figure 1-A on the following page.

1.3 Project Description

The proposed project seeks to construct fifty-four (54) single family residential units along with all necessary roadway improvements at Aspen Street and Pala Road. The Project would have 8 low-income affordable units mixed within the development. Currently the site is within a flood zone and will be raised two to three feet which will require an import of 35,000 Cubic Yards (CY) of soil. As a design feature to the project, all units will receive natural gas fireplaces and an average of three kilowatts (3 KW) of solar per unit. A site development plan is shown in Figure 1-B on Page 3 of this report.

Figure 1-A: Project Vicinity Map

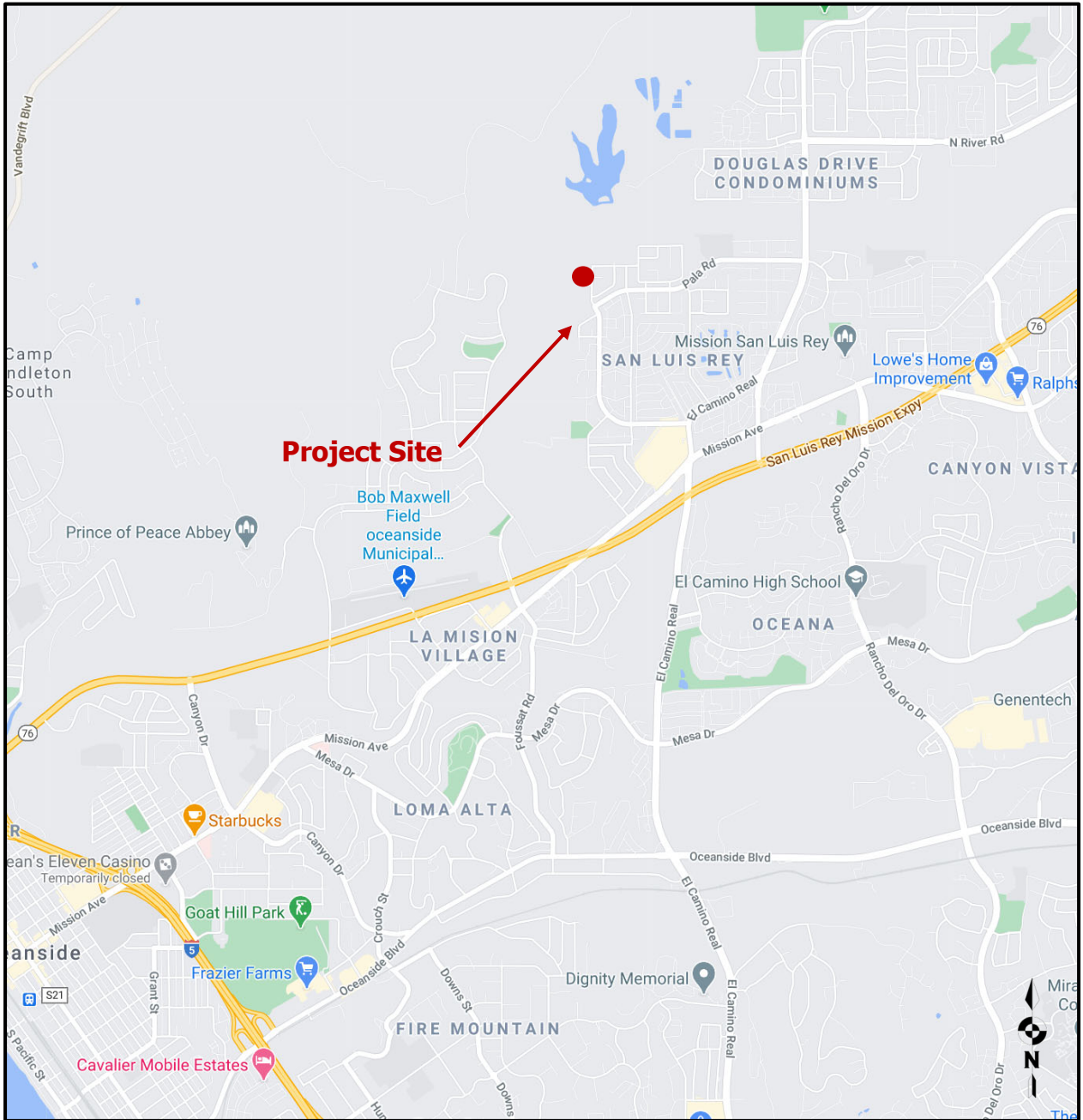

Source: Google 2020

Figure 1-B: Proposed Project Site Plan

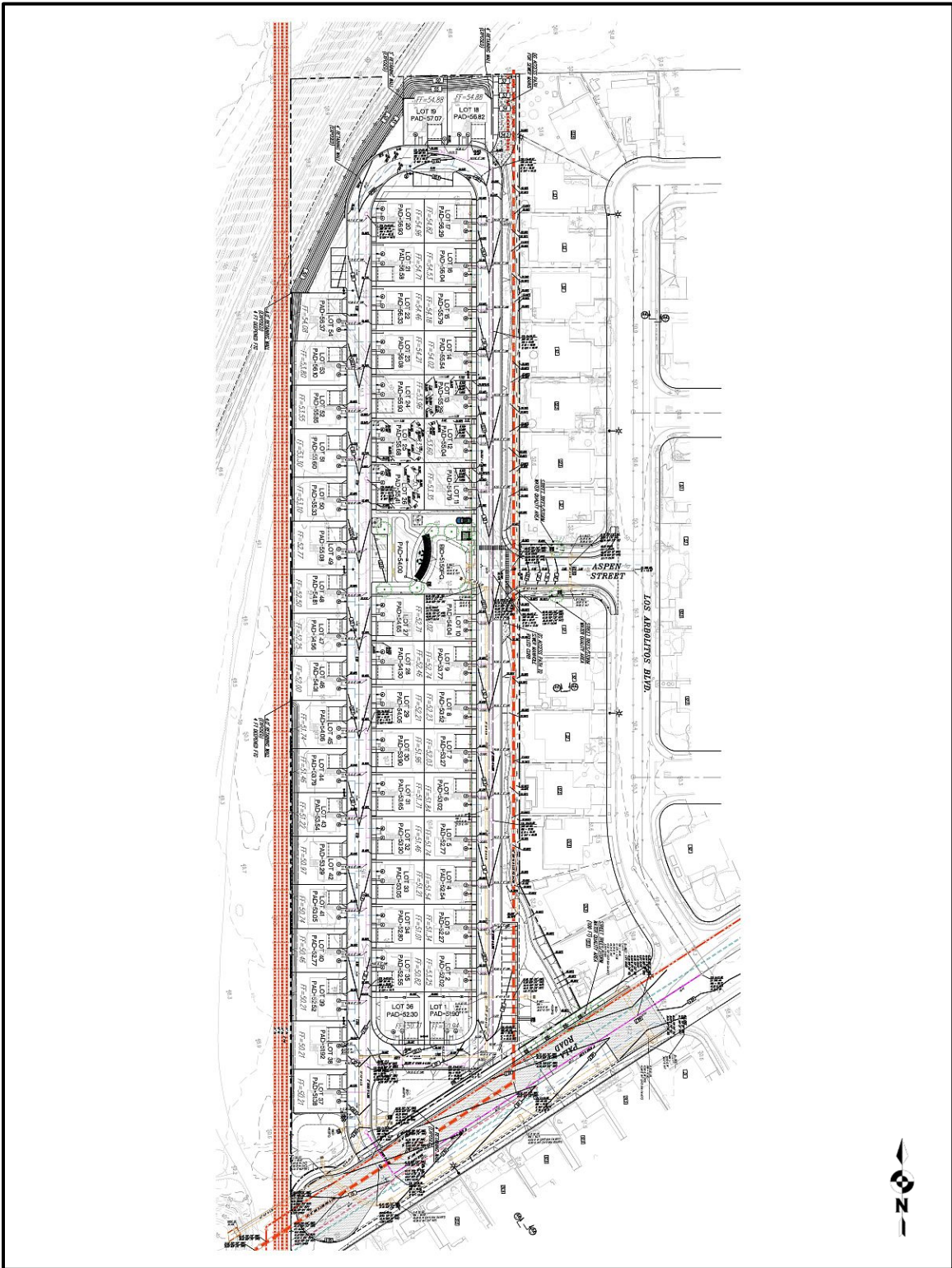

Source: Concordia , 2020

2.0 ACOUSTICAL FUNDAMENTALS

Noise is defined as unwanted or annoying sound which interferes with or disrupts normal activities. Exposure to high noise levels has been demonstrated to cause hearing loss. The individual human response to environmental noise is based on the sensitivity of that individual, the type of noise that occurs, and when the noise occurs.

Sound is measured on a logarithmic scale consisting of sound pressure levels known as a decibel (dB). The sounds heard by humans typically do not consist of a single frequency but of a broadband of frequencies having different sound pressure levels. The method for evaluating all the frequencies of the sound is to apply an A-weighting to reflect how the human ear responds to the different sound levels at different frequencies. The A-weighted sound level adequately describes the instantaneous noise whereas the equivalent sound level depicted as L_{eq} represents a steady sound level containing the same total acoustical energy as the actual fluctuating sound level over a given time interval.

The Community Noise Equivalent Level (CNEL) is the 24-hour A-weighted average for sound, with corrections for evening and nighttime hours. The corrections require an addition of 5 decibels to sound levels in the evening hours between 7 p.m. and 10 p.m. and an addition of 10 decibels to sound levels at nighttime hours between 10 p.m. and 7 a.m. These additions are made to account for the increased sensitivity during the evening and nighttime hours when sound appears louder.

A vehicle's noise level is a combination of the noise produced by a vehicle's engine, exhaust, and tires. The cumulative traffic noise levels along a roadway segment are based on three primary factors: the amount of traffic, the travel speed of the traffic, and the vehicle mix ratio or number of medium and heavy trucks. The intensity of traffic noise is increased by higher traffic volumes, greater speeds, and increased number of trucks.

Because mobile/traffic noise levels are calculated on a logarithmic scale, a doubling of the traffic noise or acoustical energy results in a noise level increase of 3 dBA. Therefore, the doubling of the traffic volume, without changing the vehicle speeds or mix ratio, results in a noise increase of 3 dBA. Mobile noise levels radiate in an almost oblique fashion from the source and drop off at a rate of 3 dBA for each doubling of distance under hard site conditions and at a rate of 4.5 dBA for soft site conditions. Hard site conditions consist of concrete, asphalt, and hard pack dirt while soft site conditions exist in areas having slight grade changes, landscaped areas, and vegetation. Alternately, fixed/point sources radiate outward uniformly as it travels away from the source. Their sound levels attenuate or drop off at a rate of 6 dBA for each doubling of distance.

The most effective noise reduction methods consist of controlling the noise at the source and blocking the noise transmission with barriers. Any or all of these methods may be required to reduce noise levels to an acceptable level. To be effective, a noise barrier must have enough mass to prevent significant noise transmission through it and high enough and long enough to shield the receiver from the noise source. A safe minimum surface weight for a noise barrier is 3.5 pounds/square foot (equivalent to 3/4-inch plywood), and the barrier must be carefully constructed so that there are no cracks or openings.

Barriers constructed of wood or as a wooden fence must have minimum design considerations as follows: the boards must be $\frac{3}{4}$ inch thick and free of any gaps or knot holes. The design must also incorporate either overlapping the boards at least 1 inch or utilizing a tongue-and-groove design for this to be achieved.

3.0 SIGNIFICANCE THRESHOLDS AND STANDARDS

3.1 Transportation Related Noise

The City of Oceanside's Noise Element requires that all exterior sensitive areas shall limit noise exposure. For noise sensitive residential land uses, the City has adopted a policy which has established a "normally acceptable" exterior noise level goal of 65 dBA CNEL for the outdoor areas and an interior noise level of less than 45 dBA CNEL.

Interior noise levels should be mitigated to a maximum of 45 dBA CNEL in all habitual rooms when the exterior of the residence are exposed to levels of 60 dBA CNEL or more. If windows and doors are required to be closed to meet the interior noise standard, then mechanical ventilation shall be provided per City requirements.

3.2 Construction Noise and Vibration

The City of Oceanside Noise Element controls noise levels due to construction operations. It shall be unlawful for any person to operate construction equipment at any construction site, except as outlined in subsections (a) and (b) below:

- (a) It shall be unlawful for any person to operate any construction equipment at a level in excess of 85 dBA at 100 feet from the source.
- (b) It should be unlawful for any person to engage in construction activities between 6 PM and 7 AM when such activities exceed the ambient noise level by 5 dBA. A special permit may be granted by the Director of Public Works if extenuating circumstances exist.

The City has not yet adopted vibration criteria. The United States Department of Transportation Federal Transit Administration (FTA) provides criteria for acceptable levels of groundborne vibration for various types of special buildings that are sensitive to vibration. For purposes of identifying potential project-related vibration impacts, the FTA criteria will be used. The human reaction to various levels of vibration is highly subjective. The upper end of the range shown for the threshold of perception, or roughly 65 VdB, may be considered annoying by some people. Vibration below 65 VdB may also cause secondary audible effects, such as a slight rattling of doors, suspended ceilings/fixtures, windows, and dishes, any of which may result in additional annoyance. Table 3-1 shows the FTA groundborne vibration and noise impact criteria for human annoyance.

Table 3-1: Groundborne Vibration and Noise Impact Criteria (Human Annoyance)

	Groundborne Vibration Impact Levels (VdB re 1 microinch/second)			Groundborne Noise Impact Levels (dB re 20 micropascals)		
	Frequent Events ¹	Occasional Events ²	Infrequent Events ³	Frequent Events ¹	Occasional Events ²	Infrequent Events ³
Category 1: Buildings where low ambient vibration is essential for interior operations.	65 VdB ⁴	65 VdB ⁴	65 VdB ⁴	N/A ⁴	N/A ⁴	N/A ⁴
Category 2: Residences and buildings where people normally sleep.	72 VdB	75 VdB	80 VdB	35 dBA	38 dBA	43 dBA
Category 3: Institutional land uses with primarily daytime use.	75 VdB	78 VdB	83 VdB	40 dBA	43 dBA	48 dBA

Source: United States Department of Transportation Federal Transit Administration (FTA), *Transit Noise and Vibration Impact Assessment*, June 2006.

¹ "Frequent Events" are defined as more than 70 vibration events per day. Most rapid transit projects fall into this category.

² "Occasional Events" are defined as between 30 and 70 vibration events of the same source per day. Most commuter truck lines have this many operations.

³ "Infrequent Events" are defined as fewer than 30 vibration events of the same kind per day. This category includes most commuter rail branch lines

⁴ This criterion limit is based on levels that are acceptable for most moderately sensitive equipment such as optical microscopes. Vibration-sensitive manufacturing or research will require detailed evaluation to define the acceptable vibration levels. Ensuring lower vibration levels in a building often requires special design of the HVAC systems and stiffened floors.

⁵ Vibration-sensitive equipment is not sensitive to groundborne noise.

In addition to the vibration annoyance standards presented above, the FTA also applies the following standards for construction vibration damage. Table 3-2 on the following page, structural damage is possible for typical residential construction when the peak particle velocity (PPV) exceeds 0.2 inch per second (in/sec). This criterion is the threshold at which there is a risk of damage to normal dwellings.

In the context of this analysis, the noise and vibration impacts associated with the construction operations will be conditioned to comply with the thresholds stated above. The potential noise and vibration impacts are analyzed separately below.

Table 3-2: Groundborne Vibration Impact Criteria (Structural Damage)

Building Category	PPV (in/sec)	VdB
I. Reinforced-concrete, steel, or timber (no plaster)	0.5	102
II. Engineered concrete and masonry (no plaster)	0.3	98
III. Non-engineered timber and masonry buildings	0.2	94
IV. Buildings extremely susceptible to vibration damage	0.12	90

Source: United States Department of Transportation Federal Transit Administration (FTA), *Transit Noise and Vibration Impact Assessment*, June 2006.

3.3 Operational Noise

Fixed sources and operational noise standards are governed by the City of Oceanside Noise Ordinance Section 38.12. Except for exempted activities and sounds as provided in this chapter or exempted properties as referenced in Section 38.15. It shall be unlawful for any person to cause or allow the creation of any noise to the extent that the one-hour average sound level, at any point on or beyond the boundaries of the property in the applicable base district zone on which the sound is produced exceeds the applicable limits set forth below in Table 3-3.

Table 3-3: Sound Level Limits

Base District Zone	7:00 a.m. to 9:59 p.m.	10:00 p.m. to 6:59 a.m.
(1) Residential Districts:		
RE (Residential Estate)	50	45
RS (Single-Family)	50	45
RM (Medium Density)	50	45
RH (High Density)	55	50
RT (Residential Tourist)	55	50
(2) C (Commercial)	65	60
(3) I (Industrial)	70	65
(4) D (Downtown)	65	55
(5) A (Agricultural)	50	45
(6) OS (Open Space)	50	45

In addition to the sound level limits established above, there are established sound level limits for PD (planned development) base district zones. For any residential land use within a PD zone, the sound level limit is that limit which would be otherwise applicable in the residential district zone (RE, RS, RM, RH or RT) corresponding to density of the residential development in that PD zone.

For any nonresidential land use within a PD zone, the sound level limit is that limit corresponding to the C (commercial) or I (industrial) zone which would be applicable to that use if not subject to the PD zone. For the purposes of this section, a land use shall be that use shown on a duly approved planned development plan or specific plan.

When property lines form the joint boundary of two (2) base district zones, the sound level limit shall be the arithmetic mean of the limit applicable to each of the two (2) zones.

4.0 NOISE ENVIRONMENT

4.1 Existing Noise Environment Onsite

Noise measurements were taken November 25, 2020, in the midday hours using a Larson-Davis Model LxT Type 1 precision sound level meter, programmed, in "slow" mode, to record noise levels in "A" weighted form. The sound level meter and microphone were mounted on a tripod, five feet above the ground and equipped with a windscreen during all measurements. The sound level meter was calibrated before and after the monitoring using a Larson-Davis calibrator, Model CAL 200.

Monitoring location 1 (ML1) was located at the southern end of the project site near Pala Road. The result of the noise level measurements are presented in Table 4-1. The noise measurements were monitored for a time period of 15 minutes during normal traffic conditions. The existing noise levels in the project area consisted primarily of traffic from nearby Pala Road and aircraft activity from nearby Oceanside Municipal Airport. The ambient Leq noise level measured in the area of the project during the midday hours was found to be roughly 48 dBA Leq. The statistical indicators Lmax, Lmin, L10, L50 and L90, are given for the monitoring location. As can be seen from the L90 data, 90% of the time the noise level is 42 dBA from roadway and aircraft activity. The noise monitoring location is provided graphically in Figure 4-A on the following page.

Table 4-1: Measured Ambient Noise Levels

Measurement Identification	Main Noise Source	Time	Noise Levels (dBA)					
			Leq	Lmin	Lmax	L10	L50	L90
M1	Pala Road	12:45–1:00 p.m.	48.1	40.0	60.2	51.0	44.4	41.9

Source: Ldn Consulting, Inc. November 25, 2020

Figure 4-A: Ambient Noise Monitoring Location

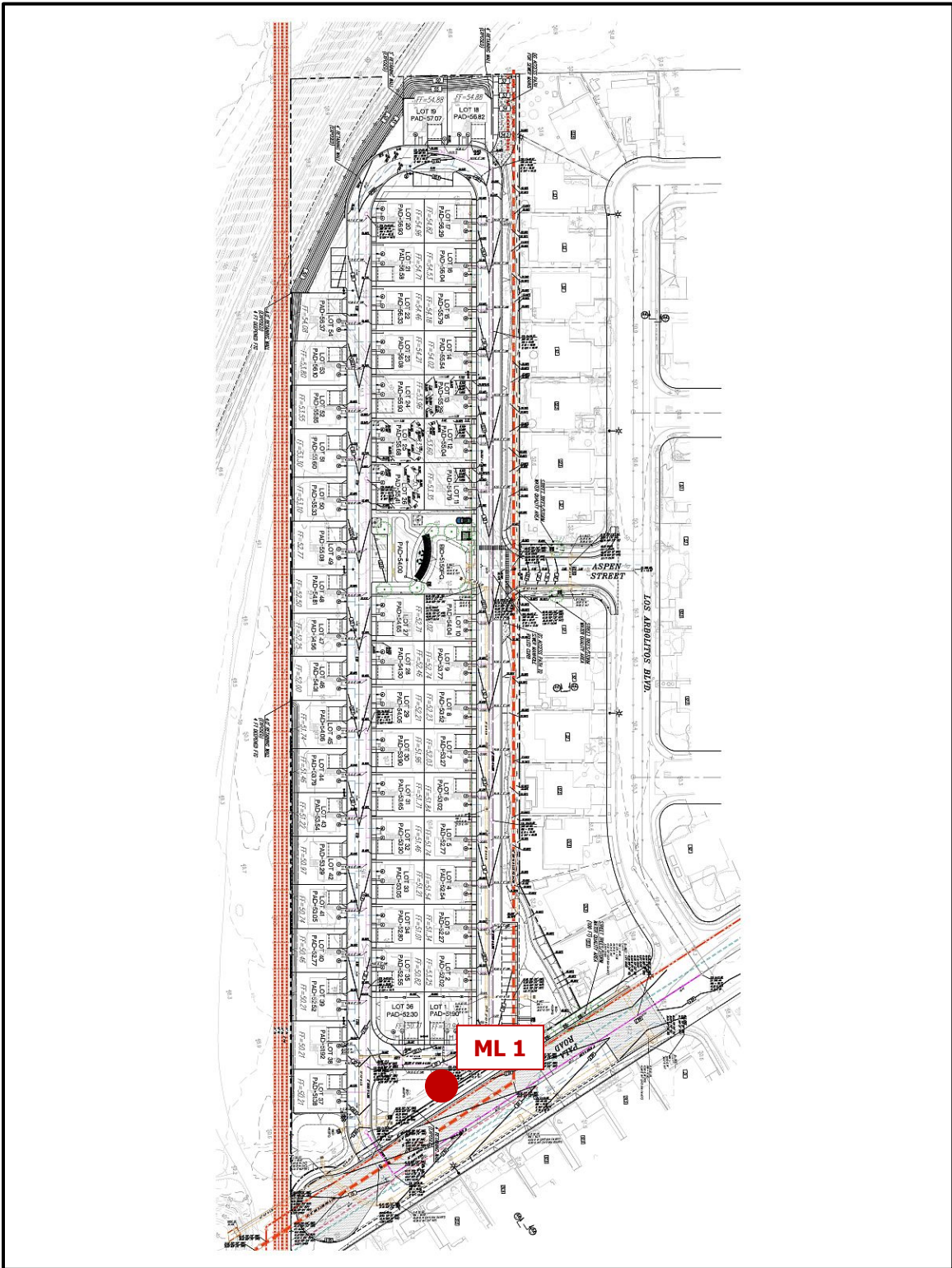

The proposed project is near the Oceanside Municipal Airport areas but is not within any of the noise contours due to infrequent aircraft over flights and therefore no mitigation to any structures or sensitive land uses is necessary due to aircraft. Noise from the Oceanside Municipal Airport would not be expected to exceed 65 dBA CNEL and therefore no mitigation to any structures or sensitive land uses due to aircraft is required. The project site location is not visible on the noise contour map of the Oceanside Municipal Airport as can be seen in Figure 4-B below.

Figure 4-B: Oceanside Municipal Airport Noise Contours/Project Location

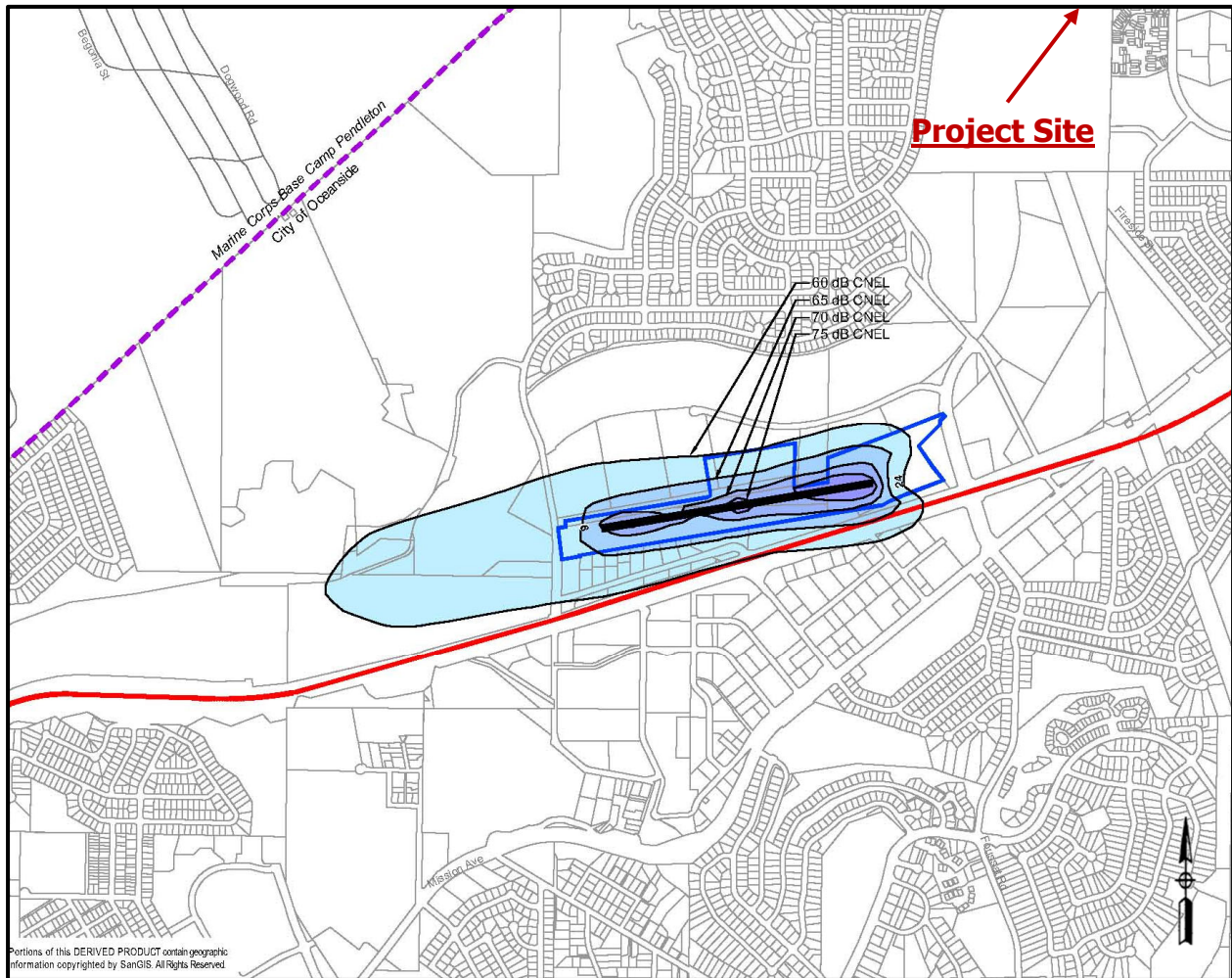

Source: Oceanside Municipal ACLUP, 2010

4.2 Onsite Roadway Noise

The primary source of noise impacts to the project site is from vehicular noise from Pala Road. The projected roadway noise levels from vehicular traffic was calculated using the methods in the Highway Noise Model published by the Federal Highway Administration (FHWA, 1978). The FHWA Model uses the traffic volume, vehicle mix, speed, and roadway geometry to compute the equivalent noise level. Table 4-2 presents the roadway parameters used in the analysis including the average daily traffic volumes, speeds and the traffic flow distribution (vehicle mix). The vehicle mix provides the distribution percentages of automobile, medium and heavy trucks for input into the FHWA Model.

Table 4-2: Traffic Parameters

Roadway	Year	Average Daily Traffic (ADT)	Peak Hour Volume	Modeled Speeds (MPH)	Vehicle Mix %		
					Auto	Medium Trucks	Heavy Trucks
Pala Road	2035	5,700 ¹	570	30	96	2	2

¹ Source: SANDAG Series 13, Model Year 2035

Based on the exterior noise model for the roadways, the worst-case exterior noise level at the building facades nearest the roadways is 63.8 dBA CNEL along Pala Road at a distance of 50-feet from the centerline. The model does not take into account any noise reductions for existing or proposed structures, barriers or topographic features. Proposed residential rear yards would be set back a minimum 75 feet from the centerline of Pala Road. Based on the increased distance from the roadway, the noise level would be reduced to a worst case exterior noise level of 62.0 dBA CNEL as seen in Figure 4-C of the following page. Based upon these findings noise mitigation is not necessary to comply with the City's 65 dBA Noise standards and no additional modeling is required.

The City of Oceanside as part of its noise guidelines also states, consistent with Title 24 of the California Code of Regulations (CCR), a project is required to perform an interior assessment on the portions of a project site where building façade noise levels are above 60 dBA CNEL in order to ensure a 45 dBA CNEL interior noise level. As determined above, façades noise levels along Pala Road are above 60 dBA CNEL. Therefore, the proposed project site will require a final noise study be prepared prior to the issuance of the first building permit for all lots. This final noise report would identify the interior noise requirements based upon the architectural floor plans showing the room dimensions and window, door and wall details.

Figure 4-C: Future Noise Levels

Project Name:	Cypress Point	Date:	9-Aug-21
Project Number:	20-65	Location:	Oceanside
Traffic Volumes, Mix and Speeds			
Mix Ratio by Percent	Autos	Med. Trucks	Heavy Trucks
	96.0	2.0	2.0
Propagation Rule	Hard		
Roadway	ADT	Speed MPH	CNEL @ 50 Feet
Pala Road	5,700	30	63.8
			60 CNEL (Feet)
			120
Noise Reduction due to Distance			
	Distance	Reduction	Resultant Level
Pala Road	75	-1.76	62.0

4.3 Offsite Project Related Transportation Noise Levels

To determine if direct or cumulative off-site noise level increases associated with the development of the proposed project would create noise impacts, the traffic volumes for the existing conditions were compared with the traffic volume increase of existing plus the proposed project. The project is estimated to only generate 540 daily trips with a peak hour volume of 54 trips according to the project transportation assessment provided by Linscott, Law, and Greenspan Engineers, dated December 11, 2020. The existing average daily traffic volume along Pala Road is 1,480 ADT. The existing average daily traffic (ADT) volumes on the remaining area roadways are more than several thousand ADT. Typically, it requires a project to double (or add 100%) the traffic volumes to have a direct impact of 3 dBA CNEL or be a major contributor to the cumulative traffic volumes. The project will add approximately 36% more traffic to Pala Road and approximately 25% or less of an increase to the remaining roadway volumes. Therefore, no direct or cumulative impacts are anticipated.

4.4 Potential Operational Noise Impacts (Non-Construction Noise)

Fixed or point sources radiate outward uniformly as sound travels away from the source. Their sound levels attenuate or drop off at a rate of 6 dBA for each doubling of distance. For example, a noise level of 75 dBA measured at 3 feet from the noise source to the receptor would be reduced to 69 dBA at 6 feet from the source to the receptor and 63 dBA at a distance of 12 feet.

Ground mechanical ventilation units (HVAC) will be installed at the proposed residential units. The project anticipates installing Carrier CA15NA (Series, 24-A) or equivalent HVAC units with a reference noise level of 71 dBA at 3-feet (Source: Carrier). The manufacturer's specifications and noise levels are provided in **Attachment A**. The HVAC units will cycle on and off throughout the day. Typically, HVAC units run for approximately 20 minutes each operating cycle to provide the necessary heating or cooling. It is anticipated that the HVAC units will operate twice in any given hour or run for 40 minutes in any given hour. Noise levels drop 3 decibels each time the duration of the source is reduced in half. Therefore, hourly HVAC noise level over a 40 minute period would be reduced approximately 2 decibels to 69 dBA based on operational time. To predict the property line noise level, a reference noise level of 69 dBA at 3-feet was used to represent the HVAC units.

The HVAC units are located a minimum of 60 feet from the property lines and are shielded by the proposed homes, solid side yard fences and solid perimeter fencing, six (6) feet in height, as shown in Figure 3-A. The solid fencing will be vinyl, ¾-inch or thicker consisting of solid panels on minimum 4x4-inch posts with no cracks or gaps through or below and all seams or cracks will be filled or caulked. The typical locations of the proposed HVAC units are also shown in Figure 4-D. Two HVAC units maybe located near each other with a side yard fence separating them and would create the worst case cumulative noise level. The remainder of the units are separated by at least 30 feet and have a 6-foot side yard fence shielding them. This separation of 30 feet would result in a 20 dBA difference between two separate HVAC units and would not cumulatively increase the noise levels. Therefore, the worst case combined noise from the HVAC would occur from two units.

Figure 4-D: Locations of the proposed HVAC Units

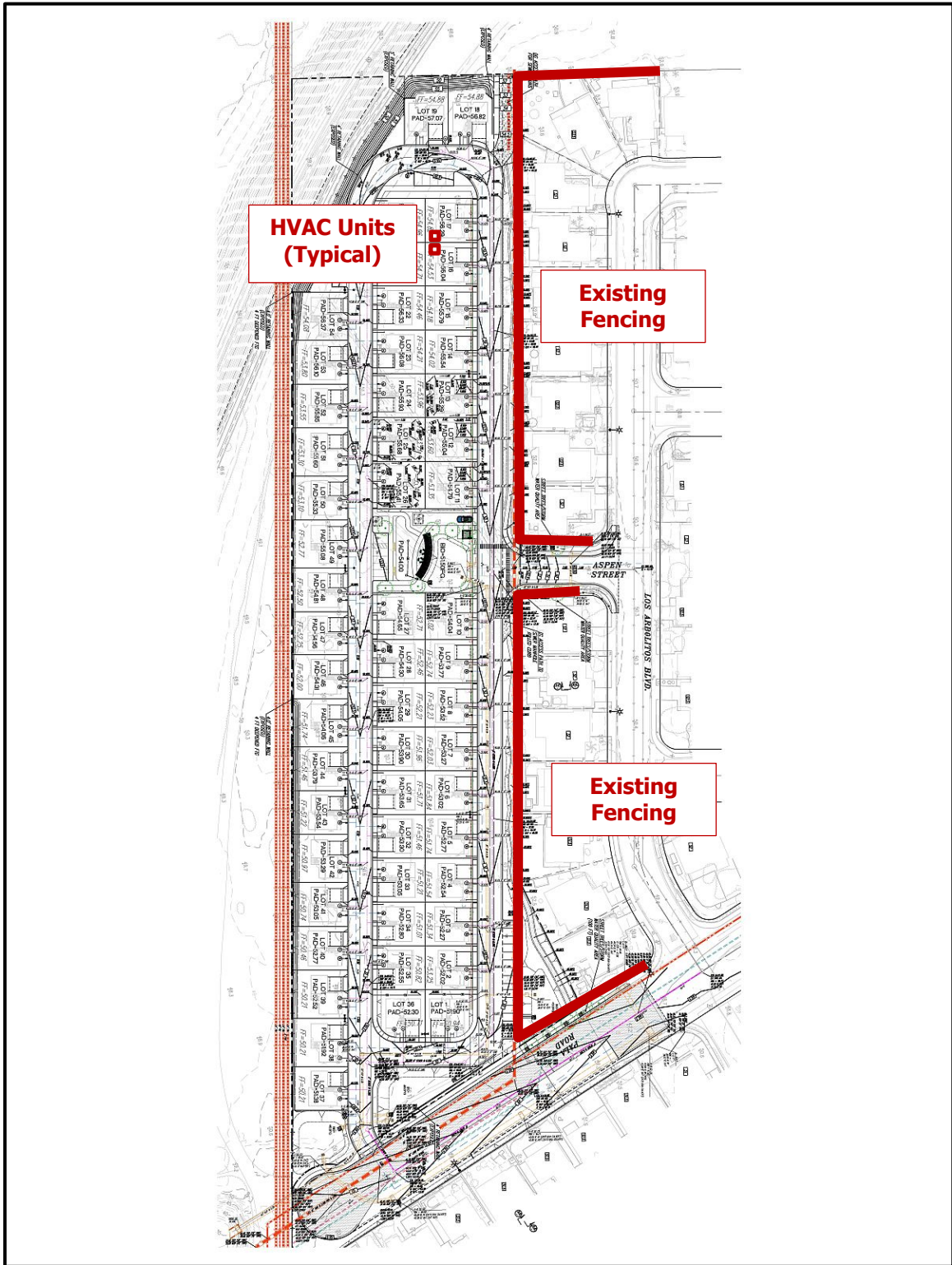

Utilizing a 6 dBA decrease per doubling of distance, noise levels at the nearest property line as described above were calculated for the HVAC. The noise levels associated with the HVAC will be limited by the existing 6-foot perimeter fencing and 6-foot side yard fencing that will shield them both visually and acoustically. The HVAC units are located a minimum of 60 feet from the nearest property lines. To determine the noise level reductions from the perimeter fencing, the Fresnel Barrier Reduction Calculations based on distance, source height, receiver elevation and the top of barrier were modeled. The adjacent receptor was located 5 feet behind the perimeter fencing. The noise level reductions due to distance and the fencing for the nearest property line is provided in Table 4-3 below. The Fresnel barrier reduction calculations for the fencing are provided in **Attachment B** of this report.

Table 4-3: Project HVAC Noise Levels (Nearest Property Line)

Noise Source	Reference Distance (Feet)	Noise Level (dBA)	Noise Reduction due to distance (dBA)	Noise Reduction from Fencing (dBA)	Resultant Noise Level @ Property Line (dBA)
AC Unit 1	3	69	-26	-8	35
AC Unit 2	3	69	-26	-8	35
CUMULATIVE PROPERTY LINE NOISE LEVEL					38

No impacts are anticipated at the property lines with the existing 6-foot perimeter fencing and proposed 6-foot side yard fencing as shown above in Figure 4-D. All other property lines are located further from the proposed HVAC units. As can be seen in Table 4-3, the resulting noise levels would be well below the most restrictive 45 dBA nighttime threshold. If the HVAC units were to have a higher rated noise level of 77 dBA at 3 feet, the resulting property line noise levels would still be below the 45 dBA nighttime threshold.

5.0 CONSTRUCTION NOISE LEVELS

Construction noise represents a short-term impact on the ambient noise levels. Noise generated by construction equipment includes haul trucks, water trucks, graders, dozers, loaders, and scrapers and can reach relatively high levels. Grading activities typically represent one of the highest potential sources for noise impacts. The most effective method of controlling construction noise is through local control of construction hours and by limiting the hours of construction to normal weekday working hours.

Because the City of Oceanside does not have property line standards for construction, the County of San Diego 75 dBA Leq standard is utilized in the analysis. Section 36.408 and 36.409 of the County of San Diego Municipal Code addresses the limits of disturbing or offensive construction noise. The Municipal Code states that with the exception of an emergency, it should be unlawful to conduct any construction activity so as to cause, at or beyond the property lines of any property zoned residential, an average sound level greater than 75 decibels during an 8-hour period from 7:00 a.m. to 7:00 p.m.

The U.S. Environmental Protection Agency (U.S. EPA) has compiled data regarding the noise generating characteristics of specific types of construction equipment. Noise levels generated by heavy construction equipment can range from 60 dBA to in excess of 100 dBA when measured at 50 feet. However, these noise levels diminish rapidly with distance from the construction site at a rate of approximately 6 dBA per doubling of distance. For example, a noise level of 75 dBA measured at 50 feet from the noise source to the receptor would be reduced to 69 dBA at 100 feet from the source to the receptor and reduced to 63 dBA at 200 feet from the source.

Using a point-source noise prediction model, calculations of the expected construction noise levels was completed. The essential model input data for these performance equations include the source levels of the equipment, source to receiver horizontal and vertical separations, the amount of time the equipment is operating in a given day (also referred to as the duty-cycle), and any transmission loss from topography or barriers.

5.1 Potential Construction Noise Impact

Based on the EPA noise emissions, empirical data and the amount of equipment needed, worst-case noise levels from the construction equipment operations would occur during the base operations (grading/site preparation). Due to physical constraints and normal site preparation operations, most of the equipment will be spread out over the site. Based upon the proposed site plan, the majority of the grading operations will occur more than 100 feet from the nearest property lines.

Therefore, the worst-case noise condition during grading would occur when the construction

equipment is working in close proximity to each other at an average distance of approximately 90 feet from the property lines. The noise levels utilized in this analysis are shown in Table 5-1. The amount of time the equipment will be utilized over an 8-hour period at this distance from the property line is also given and factored into the average noise level calculations. This is referred to as the duty-cycle.

Table 5-1: Construction Noise Levels

Equipment Type	Quantity Used	Source @ 50 Feet (dBA)	Cumulative Noise Level @ 50 Feet (dBA)
Tractor/Backhoe/Loader	1	72	72.0
Dozer Cat	1	74	74.0
Grader	1	73	73.0
Water Trucks	1	70	70.0
Scraper	1	75	75.0
Cumulative Level			80.1
Distance to Sensitive Use			90
Noise Reduction due to Distance			-5.1
Property Line Noise Level			75.0

Paving operations are expected to be in close proximity to the eastern property line adjacent to the existing residential uses. The amount of equipment utilized would be limited due to alignment and work area constraints. Noise levels from paving activities are linear and the equipment will be moving along the property line at an average distance or 20 feet from the existing residences. Based on noise measurements taken at a similar residential development the roadway paving operations are anticipated to move along the property line in 200-300 foot increments. The average hourly construction noise levels were found to be approximately 72 dBA Leq or lower at 50 feet. At a distance or 20 feet, the noise levels could increase to approximately 76-80 dBA may be experienced at local residences at any specific location. There is existing fencing at the residences that would reduce the noise levels below the average 75 decibels during an 8-hour period. Therefore, the noise levels would not exceed the construction noise levels limits and no impacts are anticipated.

5.2 Construction Noise Conclusions

As can be seen in Table 5-1, none of the proposed equipment will exceed the City of Oceanside 85 dBA standard at 100 feet from the source. The project will meet the County of San Diego 75 dBA Leq standard or all proposed equipment and no impacts are anticipated. Accordingly, impacts will be less than significant and no mitigation measures are required.

5.3 Construction Vibration Findings

The nearest vibration-sensitive uses are the residences located 50 feet or more from the proposed construction. The anticipated construction equipment will be spread out over the site working in different portion of the site as needed. For example: a single dozer may be utilized near the project boundary while the other equipment is working on the opposite side of the site. Table 5-2 lists the average vibration levels that would be experienced at the nearest vibration sensitive land uses from the temporary construction activities. Vibration levels were assessed at a distance of 50 feet to be conservative.

Table 5-2: Vibration Levels from Construction Activities (Residential Receptors)

Equipment	Approximate Velocity Level at 25 Feet (VdB)	Approximate RMS Velocity at 25 Feet (in/sec)	Approximate Velocity Level at 50 Feet (VdB)	Approximate RMS Velocity at 50 Feet (in/sec)
Small bulldozer	58	0.003	49.0	0.0011
Jackhammer	79	0.035	70.0	0.0124
Loaded trucks	86	0.076	77.0	0.0269
Large bulldozer	87	0.089	78.0	0.0315
FTA Criteria			80	0.2
Significant Impact?			No	No
¹ PPV at Distance D = PPVref x (25/D) ^{1.5}				

The FTA has determined vibration levels that would cause annoyance to a substantial number of people and potential damage to building structures. The FTA criterion for vibration induced structural damage is 0.20 in/sec for the peak particle velocity (PPV). Project construction activities would result in PPV levels below the FTA's criteria for vibration induced structural damage. Therefore, project construction activities would not result in vibration induced structural damage to residential buildings near the demolition and construction areas. The FTA criterion for infrequent vibration induced annoyance is 80 Vibration Velocity (VdB) for residential uses. Construction activities would generate levels of vibration that would not exceed the FTA

criteria for nuisance for nearby residential uses. Therefore, vibration impacts would be less than significant.

5.4 Vibration Findings

Given attenuation of vibration velocities with distance, the RMS vibration velocity and peak particle velocity at the nearest existing residence would be about 78 VdB and 0.03 inch per second, respectively. Based on the construction vibration human annoyance criterion of 80 VdB published by the FTA, the vibration levels for the construction activity on nearby residential structures will not be significant.

6.0 CERTIFICATIONS

The contents of this report represent an accurate depiction of the noise and vibration environment and impacts within and surrounding the proposed residential development. The information contained in this report was based on the best available data at the time of preparation.

DRAFT

Jeremy Loudon, Principal
Ldn Consulting, Inc.
(760) 473-1253
jloudon@ldnconsulting.net

Date August 17, 2021

ATTACHMENT A

HVAC NOISE LEVELS AND SPECIFICATIONS

**CA15NA
Single-Stage Air Conditioner
with Puron® Refrigerant
1-1/2 To 5 Tons**



Product Data



INDUSTRY LEADING FEATURES / BENEFITS

Efficiency

- 14.0 SEER / 11.7 – 12.2 EER (based on tested combination)
- Microtube Technology™ refrigeration system

Reliability

- Puron® refrigerant
- Scroll compressor
- Internal pressure relief valve
- Internal thermal overload
- Filter drier

Durability

WeatherArmor™ protection package:

- Solid, durable sheet metal construction
- Dense wire coil guard

Applications

- Long-line – up to 250 feet (76.20 m) total equivalent length, up to 200 feet (60.96 m) condenser above evaporator, or up to 80 ft. (24.38 m) evaporator above condenser (See Longline Guide for more information.)
- Low ambient (down to -20°F/-28.9°C) with accessory kit

NOTE: Ratings contained in this document are subject to change at any time. Always refer to the AHRI directory (www.ahridirectory.org) for the most up-to-date ratings information.

PRODUCT NUMBER NOMENCLATURE

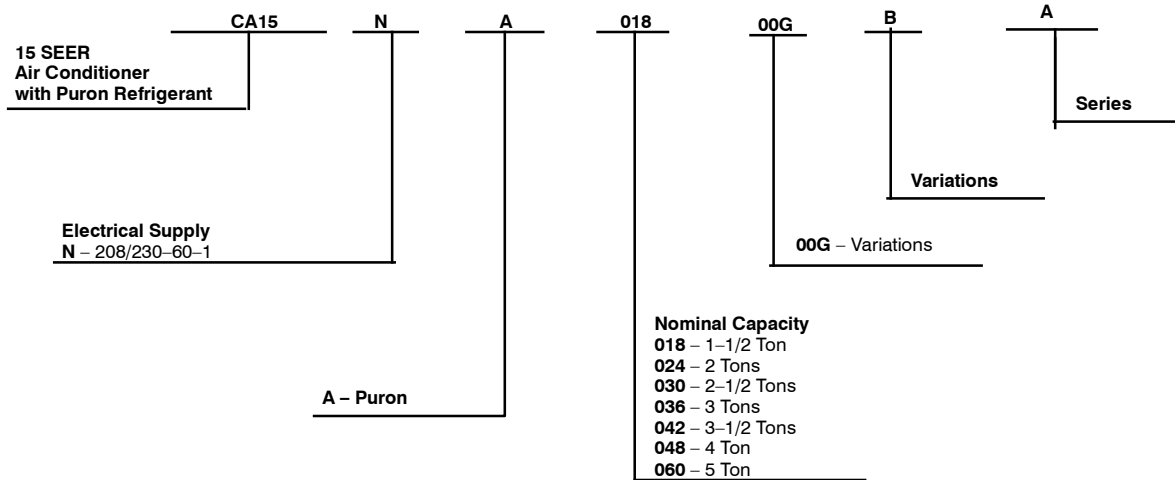

Use of the AHRI Certified TM Mark indicates a manufacturer's participation in the program. For verification of certification for individual products, go to www.ahridirectory.org.

PHYSICAL DATA

UNIT SIZE	18–A	24–A	30–A	36–A	42–A	48–A	60–A
Compressor Type	Scroll						
REFRIGERANT	Puron® (R–410A)						
Control	TXV (Puron Hard Shutoff)						
Charge (lb)	3.20 (1.45)	4.60 (2.09)	5.67 (2.57)	6.40 (2.90)	7.46 (3.38)	8.31 (3.77)	9.39 (4.26)
COND FAN	Propeller Type, Direct Drive						
Air Discharge	Vertical						
Air Qty (CFM)	1700	1881	2614	3365	3700	3545	3700
Motor HP	1/12	1/12	1/10	1/5	1/4	1/4	1/4
Motor RPM	1100	1100	1100	1100	1100	1110	1100
COND COIL							
Face Area (Sq ft)	9.85	11.2	17.24	19.4	15.1	15.1	17.25
Fins per In.	25	25	25	25	20	20	25
Rows	1	1	1	1	2	2	2
Circuits	3	5	4	5	6	6	8
VALVE CONNECT. (In. ID)							
Vapor	3/4	3/4	3/4	7/8	7/8	7/8	7/8
Liquid	3/8						
REFRIGERANT TUBES (In. OD)							
Rated Vapor*	3/4	3/4	3/4	7/8	7/8	7/8	1–1/8
Max Liquid Line	3/8						

* Units are rated with 25 ft (7.6 m) of lineset length. See Vapor Line Sizing and Cooling Capacity Loss table when using other sizes and lengths of lineset.
Note: See unit Installation Instruction for proper installation.

† See *Liquid Line Sizing For Cooling Only Systems with Puron Refrigerant* tables.

REFRIGERANT PIPING LENGTH LIMITATIONS

Liquid Line Sizing and Maximum Total Equivalent Lengths† for Cooling Only Systems with Puron® Refrigerant:

The maximum allowable length of a residential split system depends on the liquid line diameter and vertical separation between indoor and outdoor units.

See Table below for liquid line sizing and maximum lengths :

Maximum Total Equivalent Length Outdoor Unit BELOW Indoor Unit

Size	Liquid Line Connection	Liquid Line Diam. w/ TXV	AC with Puron Refrigerant Maximum Total Equivalent Length†: Outdoor unit BELOW Indoor Vertical Separation ft (m)								
			0-5 (0-1.5)	6-10 (1.8-3.0)	11-20 (3.4-6.1)	21-30 (6.4-9.1)	31-40 (9.4-12.2)	41-50 (12.5-15.2)	51-60 (15.5-18.3)	61-70 (18.6-21.3)	71-80 (21.6-24.4)
18000 AC with Puron	3/8	1/4	150	150	125	100	100	75	--	--	--
		5/16	250*	250*	250*	250*	250*	250*	250*	225*	150
		3/8	250*	250*	250*	250*	250*	250*	250*	250*	250*
24000 AC with Puron	3/8	1/4	75	75	75	50	50	--	--	--	--
		5/16	250*	250*	250*	250*	250*	225*	175	125	100
		3/8	250*	250*	250*	250*	250*	250*	250*	250*	250*
30000 AC with Puron	3/8	1/4	30	--	--	--	--	--	--	--	--
		5/16	175	225*	200	175	125	100	75	--	--
		3/8	250*	250*	250*	250*	250*	250*	250*	250*	250*
36000 AC with Puron	3/8	5/16	175	150	150	100	100	100	75	--	--
		3/8	250*	250*	250*	250*	250*	250*	250*	250*	250*
42000 AC with Puron	3/8	5/16	125	100	100	75	75	50	--	--	--
		3/8	250*	250*	250*	250*	250*	250*	250*	250*	150
48000 AC with Puron	3/8	3/8	250*	250*	250*	250*	250*	250*	230	160	--
60000 AC with Puron	3/8	3/8	250*	250*	250*	225*	190	150	110	--	--

* Maximum actual length not to exceed 200 ft (61 m)

† Total equivalent length accounts for losses due to elbows or fitting. See the Long Line Guideline for details.

-- = outside acceptable range

Maximum Total Equivalent Length Outdoor Unit ABOVE Indoor Unit

Size	Liquid Line Connection	Liquid Line Diam. w/ TXV	AC with Puron Refrigerant Maximum Total Equivalent Length†: Outdoor unit ABOVE Indoor Vertical Separation ft (m)							
			25 (7.6)	26-50 (7.9-15.2)	51-75 (15.5-22.9)	76-100 (23.2-30.5)	101-125 (30.8-38.1)	126-150 (38.4-45.7)	151-175 (46.0-53.3)	176-200 (53.6-61.0)
18000 AC with Puron	3/8	1/4	175	250*	250*	250*	250*	250*	250*	250*
		5/16	250*	250*	250*	250*	250*	250*	250*	250*
		3/8	250*	250*	250*	250*	250*	250*	250*	250*
24000 AC with Puron	3/8	1/4	100	125	175	200	225*	250*	250*	250*
		5/16	250*	250*	250*	250*	250*	250*	250*	250*
		3/8	250*	250*	250*	250*	250*	250*	250*	250*
30000 AC with Puron	3/8	1/4	30	--	--	--	--	--	--	--
		5/16	250*	250*	250*	250*	250*	250*	250*	250*
36000 AC with Puron	3/8	3/8	250*	250*	250*	250*	250*	250*	250*	250*
		5/16	225*	250*	250*	250*	250*	250*	250*	250*
42000 AC with Puron	3/8	5/16	175	200	250*	250*	250*	250*	250*	250*
		3/8	250*	250*	250*	250*	250*	250*	250*	250*
48000 AC with Puron	3/8	3/8	250*	250*	250*	250*	250*	250*	250*	250*
60000 AC with Puron	3/8	3/8	250*	250*	250*	250*	250*	250*	250*	250*

* Maximum actual length not to exceed 200 ft (61 m)

† Total equivalent length accounts for losses due to elbows or fitting. See the Long Line Guideline for details.

-- = outside acceptable range

REFRIGERANT CHARGE ADJUSTMENTS

Liquid Line Size	Puron Charge oz/ft
3/8	0.60 (Factory charge for lineset = 9 oz)
5/16	0.40
1/4	0.27

Units are factory charged for 15 ft (4.6 m) of 3/8" liquid line. The factory charge for 3/8" lineset 9 oz. When using other length or diameter liquid lines, charge adjustments are required per the chart above.

Charging Formula:

[(Lineset oz/ft x total length) – (factory charge for lineset)] = charge adjustment

Example 1: System has 15 ft of line set using existing 1/4" liquid line. What charge adjustment is required?

Formula: (.27 oz/ft x 15ft) – (9 oz) = (-4.95) oz.

Net result is to remove 4.95 oz of refrigerant from the system

Example 2: System has 45 ft of existing 5/16" liquid line. What is the charge adjustment?

Formula: (.40 oz/ft. x 45ft) – (9 oz.) = 9 oz.

Net result is to add 9 oz of refrigerant to the system

LONG LINE APPLICATIONS

An application is considered Long Line, when the refrigerant level in the system requires the use of accessories to maintain acceptable refrigerant management for systems reliability. See Accessory Usage Guideline table for required accessories. Defining a system as long line depends on the liquid line diameter, actual length of the tubing, and vertical separation between the indoor and outdoor units.

For Air Conditioner systems, the chart below shows when an application is considered Long Line.

AC WITH PURON® REFRIGERANT LONG LINE DESCRIPTION ft (m) Beyond these lengths, long line accessories are required

Liquid Line Size	Units On Same Level	Outdoor Below Indoor	Outdoor Above Indoor
1/4	No accessories needed within allowed lengths	No accessories needed within allowed lengths	175 (53.3)
5/16	120 (36.6)	50 (15.2)	120 (36.6)
3/8	80 (24.4)	35 (10.7)	80 (24.4)

Note: See Long Line Guideline for details

VAPOR LINE SIZING AND COOLING CAPACITY LOSS

Acceptable vapor line diameters provide adequate oil return to the compressor while avoiding excessive capacity loss. The suction line diameters shown in the chart below are acceptable for AC systems with Puron refrigerant:

Unit Nominal Size (Btuh)	Maximum Liquid Line Diameters (In. OD)	Vapor Line Diameters (In. OD)	Cooling Capacity Loss (%) Total Equivalent Line Length ft. (m)								
			26–50 (7.9–15.2)	51–80 (15.5–24.4)	81–100 (24.7–30.5)	101–125 (30.8–38.1)	126–150 (38.4–45.7)	151–175 (46.0–53.3)	176–200 (53.6–61.0)	201–225 (61.3–68.6)	226–250 (68.9–76.2)
18000 1 Stage AC with Puron	3/8	1/2	1	2	3	5	6	7	8	9	11
		5/8	0	1	1	1	2	2	2	3	3
		3/4	0	0	0	0	1	1	1	1	1
24000 1 Stage AC with Puron	3/8	5/8	0	1	2	2	3	3	4	5	5
		3/4	0	0	1	1	1	1	1	2	2
		7/8	0	0	0	0	0	1	1	1	1
30000 1 Stage AC with Puron	3/8	5/8	1	2	3	3	4	5	6	7	8
		3/4	0	0	1	1	1	2	2	2	3
		7/8	0	0	0	0	1	1	1	1	1
36000 1 Stage AC with Puron	3/8	5/8	1	2	4	5	6	8	9	10	12
		3/4	0	1	1	2	2	3	3	4	4
		7/8	0	0	0	1	1	1	1	2	2
42000 1 Stage AC with Puron	3/8	3/4	0	1	2	2	3	4	4	5	6
		7/8	0	0	1	1	1	2	2	2	3
		1 1/8	0	0	0	0	0	0	0	0	0
48000 1 Stage AC with Puron	3/8	3/4	0	1	2	3	4	5	5	6	7
		7/8	0	0	1	1	2	2	2	3	3
		1 1/8	0	0	0	0	0	0	0	1	1
60000 1 Stage AC with Puron	3/8	3/4	1	2	4	5	6	7	9	10	11
		7/8	0	1	2	2	3	4	4	5	5
		1 1/8	0	0	0	1	1	1	1	1	1

Applications in this area may be long line and may have height restrictions. See the *Residential Piping and Long Line Guideline*.

ACCESSORY THERMOSTATS

PART NUMBER	PROGRAM	GAS	ELECTRIC	HEAT PUMP	HEAT	COOL
TC-PAC01	5-2 Day	√	√		1	1
TC-NAC01	NP	√	√		1	1
TCSNAC01	NP	√	√		1	1

THERMOSTAT ACCESSORIES		
PART NUMBER	DESCRIPTION	THERMOSTATS USED WITH
TSTATXXCNV10‡	Thermostat Conversion Kit (4 to 5 wire) – 10 pack	All Carrier® branded thermostats
TX-LBP01	Large Decorative Backplate	TP-Pxx, TP-Nxx, TC-Pxx
TX-MBP01	Medium Decorative Backplate	TC-Nxx, TB-Pxx

ACCESSORIES

Accessory Kit Number	Description	018	024	030	036	042	048	060
HC32GE234	MOTOR,FAN	X						
HC34GE239	MOTOR,FAN		X	X				
HC38GE219	MOTOR,FAN				X	X		
HC40GE226	MOTOR,FAN						X	X
HH07AT212	BASE,THERM/SUB	X	X	X	X	X	X	X
KAACF1001MED	FILTER KIT	X	X	X	X			
KAACF1101LRG	FILTER KIT					X	X	X
KAACH1201AAA	CRKC HTR KIT					X	X	X
KAACH1401AAA	CRKC HTR KIT	X	X	X	X			
KAACS0201PTC	KIT PTC	X	X	X	X	X	X	X
KAaft0101AAA	FRZ THERM KIT	X	X	X	X	X	X	X
KAahi0501PUR	HIGH PRESSURE SW KIT	X	X	X	X	X	X	X
KAALP0401PUR	LOW PRESSURE SW KIT	X	X	X	X	X	X	X
KAALS0201LLS	SOL VALVE KIT	X	X	X	X	X	X	X
KAATD0101TDR	TIME DELAY KIT	X	X	X	X	X	X	X
KAAWS0101AAA	WINTER START KIT	X	X	X	X	X	X	X
KSACY0101AAA	CYCLE PROTRACTOR KIT	X	X	X	X	X	X	X
KSaHS1501AAA	HARD START KIT	X	X	X	X	X	X	X
KSALA0301410	LOW AMBIENT KIT	X	X	X	X	X	X	X
KSALA0601AAA	MOTORMASTER KIT	X	X	X	X	X	X	X
KSASH0601COP	SOUND BLKT KIT				X	X	X	
KSASH1801COP	SOUND BLKT KIT	X	X	X				
KSASH2101COP	SOUND BLKT KIT							X
KSATX0201PUR	TXV KIT	X	X	X				
KSATX0301PUR	TXV KIT				X	X		
KSATX0401PUR	TXV KIT						X	
KSATX0501PUR	TXV KIT							X
KSBTX0201PUR	TXV KIT	X	X	X				
KSBTX0301PUR	TXV KIT				X	X		
KSBTX0401PUR	TXV KIT						X	
TSTATXXSEN01	SENSOR	X	X	X	X	X	X	X

X = Accessory

ACCESSORY USAGE GUIDELINE

ACCESSORY	REQUIRED FOR LOW-AMBI- ENT COOLING APPLICATIONS (Below 55°F/12.8°C)	REQUIRED FOR LONG LINE APPLICATIONS* (Over 80 ft./24.38 m)	REQUIRED FOR SEA COAST APPLICATIONS (Within 2 miles/3.22 km)
Ball Bearing Fan Motor	Yes	No	No
Compressor Start Assist Capacitor and Relay	Yes	Yes	No
Crankcase Heater	Yes	Yes	No
Evaporator Freeze Thermostat	Yes	No	No
Hard Shut-Off TXV	Yes	Yes	Yes
Liquid Line Solenoid Valve	No	No	No
Motor Master® Control or Low-ambient Pressure Switch	Yes†	No	No
Support Feet	Recommended	No	Recommended
Winter Start Control	Yes	No	No

* For tubing line sets between 80 and 200 ft. (24.38 and 60.96 m) and/or 20 ft. (6.09 m) vertical differential, refer to Residential Split-System Longline Application Guideline.

† Required for Low-Ambient Controller (full modulation feature) MotorMaster® Control.

Accessory Description and Usage (Listed Alphabetically)

1. Ball-Bearing Fan Motor

A fan motor with ball bearings which permits speed reduction while maintaining bearing lubrication.

Usage Guideline:

Required on all units when MotorMaster® is used.

2. Compressor Start Assist - Capacitor and Relay

Start capacitor and relay gives a "hard" boost to compressor motor at each start up.

Usage Guideline:

Required for reciprocating compressors in the following applications:

- Long line
- Low ambient cooling
- Hard shut off expansion valve on indoor coil
- Liquid line solenoid on indoor coil

Required for single-phase scroll compressors in the following applications:

- Long line
- Low ambient cooling

Suggested for all compressors in areas with a history of low voltage problems.

3. Compressor Start Assist — PTC Type

Solid state electrical device which gives a "soft" boost to the compressor at each start-up.

Usage Guideline:

Suggested in installations with marginal power supply.

4. Crankcase Heater

An electric resistance heater which mounts to the base of the compressor to keep the lubricant warm during off cycles. Improves compressor lubrication on restart and minimizes the chance of liquid slugging.

Usage Guideline:

- Required in low ambient cooling applications.
- Required in long line applications.
- Suggested in all commercial applications.

5. Cycle Protector

The cycle protector is designed to prevent compressor short cycling. This control provides an approximate 5-minute delay after power to the compressor has been interrupted for any reason, including power outage, protector control trip, thermostat jiggling, or normal cycling.

6. Evaporator Freeze Thermostat

An SPST temperature-actuated switch that stops unit operation when evaporator reaches freeze-up conditions.

Usage Guideline:

Required when low ambient kit has been added.

7. Low-Ambient Pressure Switch Kit

A long life pressure switch which is mounted to outdoor unit service valve. It is designed to cycle the outdoor fan motor in order to maintain head pressure within normal operating limits (approximately 100 psig to 225 psig). The control will maintain working head pressure at low-ambient temperatures down to 0°F (-18°C) when properly installed.

Usage Guideline:

A Low-Ambient Pressure Switch or MotorMaster® Low-Ambient Controller must be used when cooling operation is used at outdoor temperatures below 55°F (12.8°C).

8. MotorMaster® Low-Ambient Controller

A fan-speed control device activated by a temperature sensor, designed to control condenser fan motor speed in response to the saturated, condensing temperature during operation in cooling mode only. For outdoor temperatures down to -20°F (-28.9°C), it maintains condensing temperature at 100°F ±10°F (37.8°C ± 5.5°C).

Usage Guideline:

A MotorMaster® Low Ambient Controller or Low-Ambient Pressure Switch must be used when cooling operation is used at outdoor temperatures below 55°F (12.8°C).

Suggested for all commercial applications.

9. Outdoor Air Temperature Sensor

Designed for use with Carrier Thermostats listed in this publication. This device enables the thermostat to display the outdoor temperature. This device also

is required to enable special thermostat features such as auxiliary heat lock out.

Usage Guideline:

Suggested for all Carrier thermostats listed in this publication.

Accessory Description and Usage (Listed Alphabetically) (Continued)

10. Support Feet

Four stick-on plastic feet that raise the unit 4 in. (101.6 mm) above the mounting pad. This allows sand, dirt, and other debris to be flushed from the unit base, minimizing corrosion.

Usage Guideline:

Suggested in the following applications:

Coastal installations.

Windy areas or where debris is normally circulating.

Rooftop installations.

For improved sound ratings.

11. Thermostatic Expansion Valve (TXV)

A modulating flow-control valve which meters refrigerant liquid flow rate into the evaporator in response to the superheat of the refrigerant gas leaving the evaporator.

Kit includes valve, adapter tubes, and external equalizer tube. Hard shut off types are available.

NOTE: When using a hard shut off TXV with single phase reciprocating compressors, a Compressor Start Assist Capacitor and Relay is required.

Usage Guideline:

Required to achieve AHRI ratings in certain equipment combinations. Refer to combination ratings.

Hard shut off TXV or LLS required in air conditioner long line applications.

Required for use on all zoning systems.

12. Time-Delay Relay

An SPST delay relay which briefly continues operation of indoor blower motor to provide additional cooling after the compressor cycles off.

NOTE: Most indoor unit controls include this feature. For those that do not, use the guideline below.

Usage Guideline:

For improved efficiency ratings for certain combinations of indoor and outdoor units. Refer to AHRI Unitary Directory.

13. Winter Start Control

This control is designed to alleviate nuisance opening of the low-pressure switch by bypassing it for the first 3 minutes of operation.

ELECTRICAL DATA

UNIT SIZE - SERIES	V/PH	OPER VOLTS*		COMPR		FAN	MCA	MAX FUSE† or CKT BRK AMPS
		MAX	MIN	LRA	RLA	FLA		
18-A	208/230/1-60	253	197	47.5	9.0	0.40	11.7	20
24-A				62.9	10.9	0.50	14.1	20
30-A				67.8	12.8	0.75	16.8	25
36-A				79.0	13.6	1.10	18.1	30
42-A				109.0	16.7	1.40	22.3	35
48-A				105.7	15.6	1.40	20.9	35
60-A				127.1	20.8	1.52	27.5	40

* Permissible limits of the voltage range at which the unit will operate satisfactorily

† Time-Delay fuse.

FLA - Full Load Amps

LRA - Locked Rotor Amps

MCA - Minimum Circuit Amps

RLA - Rated Load Amps

NOTE: Control circuit is 24V on all units and requires external power source. Copper wire must be used from service disconnect to unit.
All motors/compressors contain internal overload protection.

Complies with 2010 requirements of ASHRAE Standards 90.1

A-WEIGHTED SOUND POWER (dBA)

UNIT SIZE - SERIES	Standard Rating (dBA)	TYPICAL OCTAVE BAND SPECTRUM (dBA without tone adjustment)						
		125	250	500	1000	2000	4000	8000
18-A	75	46.0	55.0	59.5	64.0	60.5	54.5	48.5
24-A	71	50.5	53.5	58.5	60.5	60.0	56.5	52.5
30-A	73	49.5	56.0	62.5	64.0	60.5	57.5	53.5
36-A	75	49.0	57.0	62.5	66.0	61.0	58.5	52.0
42-A	75	52.5	63.0	64.0	63.0	62.0	58.0	52.0
48-A	76	53.0	61.0	64.0	65.5	62.0	59.5	50.5
60-A	75	53.5	57.0	62.5	63.5	61.5	57.5	51.0

NOTE: Tested in compliance with AHRI 270-1995 (not listed with AHRI)

A-WEIGHTED SOUND POWER (dBA) WITH SOUND SHIELD

UNIT SIZE - SERIES	Standard Rating (dBA)	TYPICAL OCTAVE BAND SPECTRUM (dBA without tone adjustment)						
		125	250	500	1000	2000	4000	8000
18-A	75	46.5	55.5	59.5	63.5	60.0	54.0	47.0
24-A	71	47.5	53.5	58.0	59.5	60.0	55.5	49.0
30-A	72	49.0	56.5	61.5	62.5	60.0	57.0	52.0
36-A	73	49.5	57.0	62.0	64.0	60.0	58.0	51.0
42-A	74	53.5	64.0	64.0	62.5	61.0	56.5	50.5
48-A	73	54.5	61.0	63.5	62.5	60.0	56.5	47.5
60-A	73	53.5	59.0	63.0	62.5	59.5	56.0	48.0

NOTE: Tested in compliance with AHRI 270-1995 (not listed with AHRI)

METERING DEVICE

UNIT SIZE - SERIES	INDOOOR	REQUIRED SUBCOOLING °F (°C)
18-A	TXV*	13 (7.22)
24-A		10 (5.56)
30-A		12 (6.67)
36-A		11 (6.11)
42-A		11 (6.11)
48-A		11 (6.11)
60-A		13 (7.22)

* TXV must be ordered separately when indoor coil is not equipped with a TXV. TXV must be hard-shutoff type.

DIMENSIONS - ENGLISH

UNIT	SERIES	ELECTRICAL CHARACTERISTICS				A	B	C	D	E	F	G	K	L	M	N	P	OPERATING WEIGHT (LBS)	SHIPPING WEIGHT (LBS)	SHIPPING DIMENSIONS (L x W x H)		
CA15NA018	A	X	0	0	0	25 3/4"	25"	3 3/4"	3/4"	4 7/16"	21 1/4"	9 1/8"	2 13/16"	1/2"	13"	15 1/4"	9 3/4"	122	145	26 7/8" X 26 7/8" X 32 9/16"		
CA15NA024	A	X	0	0	0	25 3/4"	32 5/16"	3 3/4"	3/4"	4 7/16"	21 1/4"	9 1/8"	2 13/16"	1/2"	13 3/8"	13 1/4"	15 1/16"	123	148	26 7/8" X 26 7/8" X 36 5/8"		
CA15NA030	A	X	0	0	0	31 3/16"	31 13/16"	3 3/4"	3/4"	6 9/16"	24 11/16"	9 1/8"	2 13/16"	1/2"	16 1/8"	15 1/16"	12 5/8"	151	186	32 3/16" X 32 3/16" X 34"		
CA15NA036	A	X	0	0	0	31 3/16"	35 3/16"	3 7/8"	7/8"	6 9/16"	24 11/16"	9 1/8"	2 15/16"	5/8"	16 1/8"	16 3/8"	14 7/16"	151	171	32 3/16" X 32 3/16" X 37 7/16"		
CA15NA042	A	X	0	0	0	31 3/16"	28 7/16"	3 7/8"	7/8"	6 9/16"	24 11/16"	9 1/8"	2 15/16"	5/8"	15 7/8"	17"	11 7/8"	191	226	32 3/16" X 32 3/16" X 30 5/8"		
CA15NA048	A	X	0	0	0	31 3/16"	28 7/16"	3 7/8"	7/8"	6 9/16"	24 11/16"	9 1/8"	2 15/16"	5/8"	16 3/16"	16 1/4"	10 1/4"	182	200	32 3/16" X 32 3/16" X 30 5/8"		
CA15NA060	A	X	0	0	0	31 3/16"	31 13/16"	3 7/8"	7/8"	6 9/16"	24 11/16"	9 1/8"	2 15/16"	5/8"	15 1/2"	16"	10 7/8"	197	218	32 3/16" X 32 3/16" X 34"		

208-230-160	230-160	208/230-3-60	460-3-60
-------------	---------	--------------	----------

X = YES
O = NO

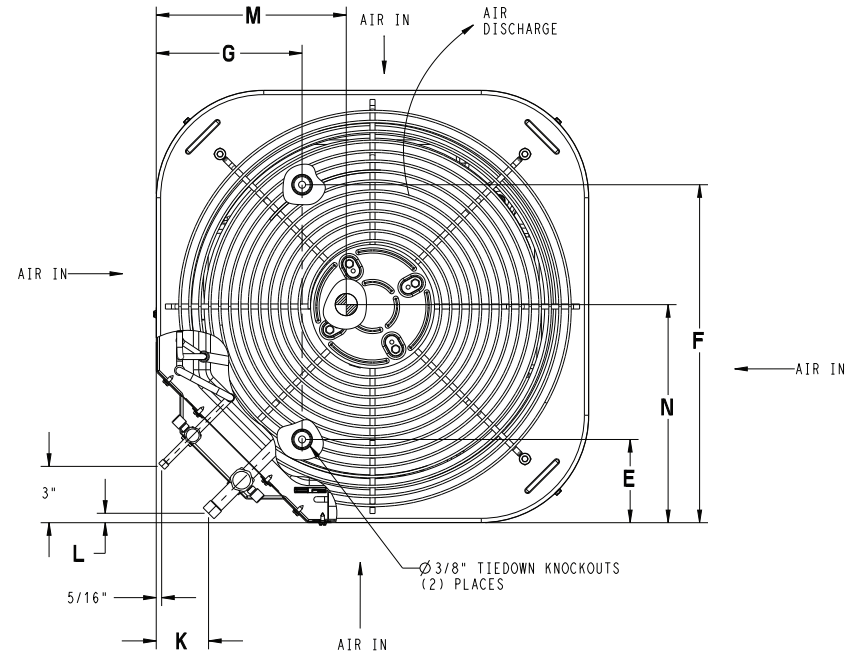
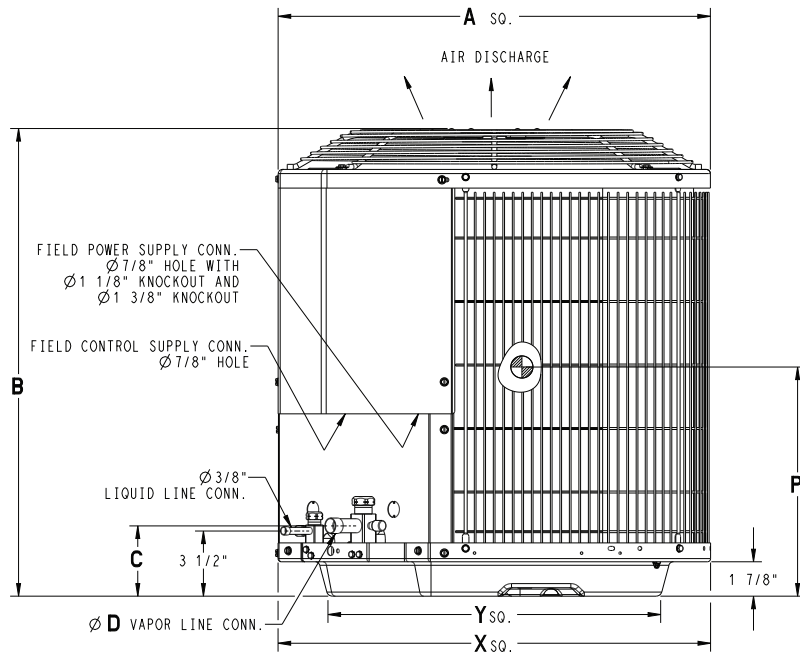

UNIT SIZE	"X" MIN GROUND MOUNTING PAD APPLICATION DIMENSIONS	"Y" MIN ROOF-TOP MOUNTING PAD APPLICATION DIMENSIONS
-	23 1/8"	17 3/4"
18, 24	25 3/4"	20 7/16"
30, 36, 42, 48, 60	31 3/16"	23"
-	35"	26 3/4"

When installing, allow sufficient space for airflow clearance, wiring, refrigerant piping, and service. Allow 24 in. (609.6 mm) clearance to service end of unit and 48 in. (1219.2 mm) (above unit). For proper airflow, a 6-in. (152.4 mm) clearance on 1 side of unit and 12-in. (304.8 mm) on all remaining sides must be maintained. Maintain a distance of 24 in. (609.6 mm) between units or 18 in. (457.2 mm) if no overhang within 12 ft. (3.66 m) Position so water, snow, or ice from roof or eaves cannot fall directly on unit.

NOTE: 18" (457.2 mm) clearance option described above is approved for outdoor units with wire grille coil guard only. Units with louver panels require 24" (609.6 mm) between units.

On rooftop applications, locate unit at least 6 in. (152.4 mm) above roof surface.

ATTACHMENT B

FRESNEL BARRIER REDUCTION
CALCULATIONS

Elevated Point Source

Source to Receiver Horizontal Distance (ft) = 65.00
Source to Barrier Horizontal Distance (ft) = 60.00
Barrier to Receiver Horizontal Distance (ft) = 5.00
Source Height (ft) = 3.00
Receiver Height (ft) = 5.00
Barrier Height (ft) = 6.00
Distance Source to Receptor (ft) d = 65.03
Distance Source to Barrier top (ft) d1 = 60.07
Distance Barrier top to Receiver (ft) d2 = 5.10

Frequency (Hz) = 8000	Attenuation (db) = 16.0	Fresnel N = 2.033
Frequency (Hz) = 4000	Attenuation (db) = 13.4	Fresnel N = 1.017
Frequency (Hz) = 2000	Attenuation (db) = 11.3	Fresnel N = 0.508
Frequency (Hz) = 1000	Attenuation (db) = 9.5	Fresnel N = 0.254
Frequency (Hz) = 500	Attenuation (db) = 8.1	Fresnel N = 0.127
Frequency (Hz) = 250	Attenuation (db) = 6.9	Fresnel N = 0.064
Frequency (Hz) = 125	Attenuation (db) = 5.9	Fresnel N = 0.032
Frequency (Hz) = 63	Attenuation (db) = 5.2	Fresnel N = 0.016

