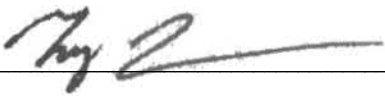

Appendix I

Storm Water Quality Management Plan (2016)

(T22-00004 / D22-00009 / DB22-00005)

CITY OF OCEANSIDE ENGINEERING DIVISION
PRIORITY DEVELOPMENT PROJECT STORM WATER QUALITY MANAGEMENT PLAN FOR GUAJOME LAKE T22-00004 / D22-00009 / DB22-00005
ENGINEER OF WORK  Tyler Lawson, PE #80356

PREPARED FOR:

RINCON HOMES INC.
5315 AVENIDA ENCINAS SUITE 200
CARLSBAD, CA 92008
(888)-357-3553

PREPARED BY:

PASCO LARET SUITER & ASSOCIATES
1911 SAN DIEGO AVE, UNIT 100
SAN DIEGO, CA 92110
(858)-259-4812



How to Use This Template

This template, assembled by GHD Inc. on behalf of the City of Oceanside, is for the development of Storm Water Quality Management Plans (SWQMPs) for Priority Development Projects (PDPs) proposed within Oceanside, CA. It is based on requirements set forth in the Regional Water Quality Control Board's National Pollutant Discharge Elimination System MS4 Permit that covers the San Diego Region (Order No. R9-2013-0001).

All references within the template refer to the City of Oceanside BMP Design Manual dated February 2016 (Manual). Use of this template in conjunction with the Manual is intended to help a project applicant develop a SWQMP compliant with City of Oceanside and MS4 Permit requirements.

Template Date: February 16, 2016

Assembled By:



Quick Reference Guide

Item	Project Information
Project Name	GUAJOME LAKE
Application Number(s)	T22-00004 / G22-00009 / DB22-00005
Project Address	Unassigned on Guajome Lake Road, Oceanside, CA 92054
Total Parcel Area	731,283 sq. ft.
Project Description	<p>Project description should touch briefly on all of the following elements;</p> <ul style="list-style-type: none"> • Project size: Our project site is roughly 16.788 acres. • Existing site use and cover: There is an existing vacant lot covered in natural vegetation. • Proposed site use and cover: Clearing and grading of the site for the construction of 83 single-family units with hardscape and utility improvements typical to this type of development.
Proposed (Overall) Disturbed Area	458,900 sq. ft.
Created or Replaced Impervious	281,300 sq. ft.
Project Hydrologic Unit Watershed	<input type="checkbox"/> Santa Maria <input checked="" type="checkbox"/> San Luis Rey <input type="checkbox"/> Carlsbad
Required to implement HMP	<input checked="" type="checkbox"/> Yes <input type="checkbox"/> No



Table of Contents

CERTIFICATION PAGE	Section 1
SUBMITTAL RECORD	Section 2
PROJECT VICINITY MAP	Section 3
FORM I-1: APPLICABILITY OF PERMANENT STORM Water BMP REQUIREMENTS	Section 4
FORM I-2: PROJECT TYPE DETERMINATION CHECKLIST	Section 5
FORM I-3B: SITE INFORMATION CHECKLIST	Section 6
FORM I-4: SOURCE CONTROL BMP CHECKLIST	Section 7
FORM I-5: SITE DESIGN BMP CHECKLIST	Section 8
FORM I-6: SUMMARY OF PDP STRUCTURAL BMPS	Section 9
BMP CONSTRUCTION SELF CERTIFICATION FORM	Section 10
ATTACHMENT 1: BACKUP FOR PDP POLLUTANT CONTROL BMPS	Section 11
ATTACHMENT 1a: DMA Exhibit.....	Section 11
ATTACHMENT 1b: Tabular Summary of DMAs	Section 11
ATTACHMENT 1c: Design Capture Volume Worksheet	Section 11
ATTACHMENT 1d: FORM I-7: Harvest and Use Feasibility Screening Checklist	Section 11
ATTACHMENT 1e: FORM I-8: Categorization of Infiltration Feasibility Condition	Section 11
ATTACHMENT 1f: Pollutant Control BMP Design Worksheets/Calculations	Section 11
ATTACHMENT 2: BACKUP FOR PDP HYDROMODIFICATION CONTROL MEASURES	Section 12
ATTACHMENT 2a: Hydromodification Management Exhibit.....	Section 12
ATTACHMENT 2b: Management of Critical Coarse Sediment Yield Areas	Section 12
ATTACHMENT 2c: Geomorphic Assessment of Receiving Channels.....	Section 12
ATTACHMENT 2d: Flow Control Facility Design and BMP Drawdown Calculations	Section 12
ATTACHMENT 2e: Vector Control Plan	Section 12
ATTACHMENT 3: STRUCTURAL BMP MAINTENANCE INFORMATION	Section 13
ATTACHMENT 3a: Structural BMP Maintenance Thresholds and Actions.....	Section 13
ATTACHMENT 3b: Management of Critical Coarse Sediment Yield Areas	Section 13
ATTACHMENT 4: STORM WATER BMP PLAN SHEETS	Section 14
ATTACHMENT 5: DRAINAGE REPORT	Section 15
ATTACHMENT 6: GEOTECHNICAL AND GROUNDWATER INVESTIGATION REPORT	Section 16
ATTACHMENT 7: STORM WATER QUALITY ASSESSMENT FORM	Section 17
ADDITIONAL SUPPORTING DOCUMENTATION	Section 18



CERTIFICATION PAGE

Project Name: GUAJOME LAKE

Permit Application Number: [T22-00004 / G22-00009 / DB22-00005]

I hereby declare that I am the Engineer in Responsible Charge of design of storm water BMPs for this project, and that I have exercised responsible charge over the design of the project as defined in Section 6703 of the Business and Professions Code, and that the design is consistent with the requirements of the City of Oceanside BMP Design Manual, which is based on the requirements of San Diego Regional Water Quality Control Board Order No. R9-2013-0001 (MS4 Permit).

I have read and understand that the City has adopted minimum requirements for managing urban runoff, including storm water, from land development activities, as described in the BMP Design Manual. I certify that this SWQMP has been completed to the best of my ability and accurately reflects the project being proposed and the applicable source control and site design BMPs proposed to minimize the potentially negative impacts of this project's land development activities on water quality. I understand and acknowledge that the plan check review of this SWQMP by City staff is confined to a review and does not relieve me, as the Engineer in Responsible Charge of design of storm water BMPs for this project, of my responsibilities for project design.

As Engineer of Work, I agree to indemnify, defend, and hold harmless the City of Oceanside, its officers, agents, and employees from any and all liability, claims, damages, or injuries to any person or property which might arise from the negligent acts, errors, or omissions of the Engineer of Work, my employees, agents or consultants.

 80356 12/31/2024

Engineer of Work's Signature, PE Number & Expiration Date

TYLER G. LAWSON

Print Name

PASCO LARET SUITER & ASSOCIATES

Company

Date

Engineer's Seal:



SUBMITTAL RECORD

Use this Table to keep a record of submittals of this SWQMP. Each time the SWQMP is re-submitted, provide the date and status of the project. In last column indicate changes that have been made or indicate if response to plancheck comments is included. When applicable, insert response to plancheck comments behind this page.

Submittal Number	Date	Project Status	Changes
1	5/17/22	<input checked="" type="checkbox"/> Preliminary Design/ Planning/ CEQA <input type="checkbox"/> Final Design	Initial Submittal
2	10/31/22	<input checked="" type="checkbox"/> Preliminary Design/ Planning/ CEQA <input type="checkbox"/> Final Design	Resubmittal
3	02/12/23	<input checked="" type="checkbox"/> Preliminary Design/ Planning/ CEQA <input type="checkbox"/> Final Design	Resubmittal
4	05/15/23	<input checked="" type="checkbox"/> Preliminary Design/ Planning/ CEQA <input type="checkbox"/> Final Design	Resubmittal
5	04/04/24	<input checked="" type="checkbox"/> Preliminary Design/ Planning/ CEQA <input type="checkbox"/> Final Design	Resubmittal



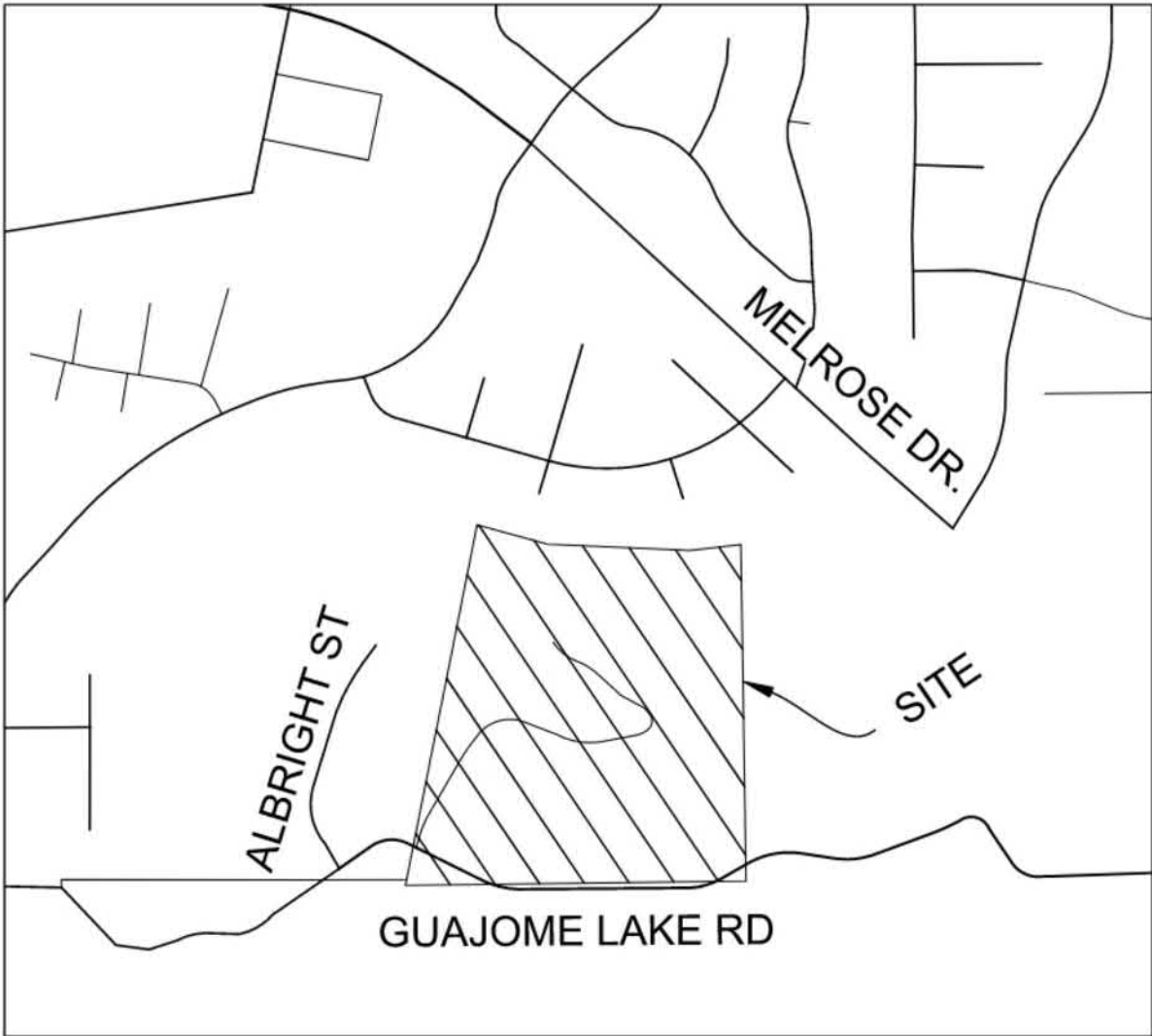

VICINITY MAP
NOT TO SCALE



Applicability of Permanent, Post-Construction Storm Water BMP Requirements (Storm Water Intake Form for all Development Permit Applications)		Form I-1
Project Identification		
Project Name: GUAJOME LAKE		
Permit Application Number: T22-00004 / G22-00009 / DB22-00005		Date: 4/4/24
Determination of Requirements		
<p>The purpose of this form is to identify permanent, post-construction requirements that apply to the project. This form serves as a short <u>summary</u> of applicable requirements, in some cases referencing separate forms that will serve as the backup for the determination of requirements.</p> <p>Answer each step below, starting with Step 1 and progressing through each step until reaching "Stop". Refer to the manual sections and/or separate forms referenced in each step below.</p>		
Step	Answer	Progression
Step 1: Is the project a "development project"? See Section 1.3 of the manual for guidance.	<input checked="" type="checkbox"/> Yes	Go to Step 2.
	<input type="checkbox"/> No	Stop. Permanent BMP requirements do not apply. No SWQMP will be required. Provide discussion below.
Discussion / justification if the project is <u>not</u> a "development project" (e.g., the project includes <i>only</i> interior remodels within an existing building):		
Step 2: Is the project a Standard Project, PDP, or exception to PDP definitions? To answer this item, see Section 1.4 of the manual <i>in its entirety</i> for guidance, AND complete Form I-2, Project Type Determination.	<input type="checkbox"/> Standard Project	Stop. Standard Project requirements apply, including Standard Project SWQMP.
	<input checked="" type="checkbox"/> PDP	PDP requirements apply, including PDP SWQMP. Go to Step 3.
	<input type="checkbox"/> Exception to PDP definitions	Stop. Standard Project requirements apply. Provide discussion and list any additional requirements below. Prepare Standard Project SWQMP.
Discussion / justification, and additional requirements for exceptions to PDP definitions, if applicable:		



Step	Answer	Progression
Step 3. Is the project subject to earlier PDP requirements due to a prior lawful approval? See Section 1.10 of the manual for guidance.	<input type="checkbox"/> Yes	Consult the [City Engineer] to determine requirements. Provide discussion and identify requirements below. Go to Step 4.
	<input checked="" type="checkbox"/> No	BMP Design Manual PDP requirements apply. Go to Step 4.
Discussion / justification of prior lawful approval, and identify requirements (<i>not required if prior lawful approval does not apply</i>):		
Step 4. Do hydromodification control requirements apply? See Section 1.6 of the manual for guidance.	<input checked="" type="checkbox"/> Yes	PDP structural BMPs required for pollutant control (Chapter 5) and hydromodification control (Chapter 6). Go to Step 5.
	<input type="checkbox"/> No	Stop. PDP structural BMPs required for pollutant control (Chapter 5) only. Provide brief discussion of exemption to hydromodification control below.
Discussion / justification if hydromodification control requirements do <u>not</u> apply:		
Step 5. Does protection of critical coarse sediment yield areas apply? See Section 6.2 of the manual for guidance.	<input checked="" type="checkbox"/> Yes	Management measures required for protection of critical coarse sediment yield areas (Chapter 6.2). Stop.
	<input type="checkbox"/> No	Management measures not required for protection of critical coarse sediment yield areas. Provide brief discussion below. Stop.
Discussion / justification if protection of critical coarse sediment yield areas does <u>not</u> apply:		



Project Type Determination Checklist		Form I-2	
Project Information			
Project Name: GUAJOME LAKE ROAD			
Permit Application Number: T22-00004 / G22-00009 / DB22-00005			
Project Type Determination: Standard Project or PDP			
The project is (select one): <input checked="" type="checkbox"/> New Development <input type="checkbox"/> Redevelopment			
The total proposed newly created or replaced impervious area is: <u>281,300</u> ft ² (<u>6.46</u>) acres			
Is the project in any of the following categories, (a) through (f)?			
Yes <input checked="" type="checkbox"/>	No <input type="checkbox"/>	(a)	New development projects that create 10,000 square feet or more of impervious surfaces (collectively over the entire project site). This includes commercial, industrial, residential, mixed-use, and public development projects on public or private land.
Yes <input type="checkbox"/>	No <input checked="" type="checkbox"/>	(b)	Redevelopment projects that create and/or replace 5,000 square feet or more of impervious surface (collectively over the entire project site on an existing site of 10,000 square feet or more of impervious surfaces). This includes commercial, industrial, residential, mixed-use, and public development projects on public or private land.
Yes <input type="checkbox"/>	No <input checked="" type="checkbox"/>	(c)	<p>New and redevelopment projects that create 5,000 square feet or more of impervious surface (collectively over the entire project site), and support one or more of the following uses:</p> <ul style="list-style-type: none"> (i) Restaurants. This category is defined as a facility that sells prepared foods and drinks for consumption, including stationary lunch counters and refreshment stands selling prepared foods and drinks for immediate consumption SIC code 5812). (ii) Hillside development projects. This category includes development on any natural slope that is twenty-five percent or greater. (iii) Parking lots. This category is defined as a land area or facility for the temporary parking or storage of motor vehicles used personally, for business, or for commerce. (iv) Streets, roads, highways, freeways, and driveways. This category is defined as any paved impervious surface used for the transportation of automobiles, trucks, motorcycles, and other vehicles.



Form I-2 Page 2 of 2

Yes <input type="checkbox"/>	No <input checked="" type="checkbox"/>	(d)	<p>New or redevelopment projects that create or replace 2,500 square feet or more of impervious surface (collectively over the entire project site), and discharging directly to an Environmentally Sensitive Area (ESA). “Discharging directly to” includes flow that is conveyed overland a distance of 200 feet or less from the project to the ESA, or conveyed in a pipe or open channel any distance as an isolated flow from the project to the ESA (i.e. not commingled with flows from adjacent lands).</p> <p><u>Note: ESAs are areas that include but are not limited to all Clean Water Act Section 303(d) impaired water bodies; areas designated as Areas of Special Biological Significance by the State Water Board and SDRWQCB; State Water Quality Protected Areas; water bodies designated with the RARE beneficial use by the State Water Board and SDRWQCB; and any other equivalent environmentally sensitive areas which have been identified by the Copermittees. See manual Section 1.4.2 for additional guidance.</u></p>
Yes <input type="checkbox"/>	No <input checked="" type="checkbox"/>	(e)	<p>New development projects that support one or more of the following uses:</p> <p>(i) Automotive repair shops. This category is defined as a facility that is categorized in any one of the following SIC codes: 5013, 5014, 5541, 7532-7534, or 7536-7539.</p> <p>(ii) Retail gasoline outlets. This category includes retail gasoline outlets that meet the following criteria: (a) 5,000 square feet or more or (b) a projected Average Daily Traffic of 100 or more vehicles per day.</p>
Yes <input checked="" type="checkbox"/>	No <input type="checkbox"/>	(f)	<p>New or redevelopment projects that result in the disturbance of one or more acres of land and are expected to generate pollutants post construction.</p> <p><i>Note: See manual Section 1.4.2 for additional guidance.</i></p>

Does the project meet the definition of one or more of the PDP categories (a) through (f) listed above?

No – the project is not a PDP (Standard Project).

Yes – the project is a PDP.

The following is for redevelopment PDPs only:

The area of existing (pre-project) impervious area at the project site is: ____ ft² (A)

The total proposed newly created or replaced impervious area is: ____ ft² (B)

Percent impervious surface created or replaced (A/B)*100: ____%

The percent impervious surface created or replaced is (select one based on the above calculation):

less than or equal to fifty percent (50%) – only new impervious areas are considered PDP

OR

greater than fifty percent (50%) – the entire project site is a PDP



Site Information Checklist For PDPs		Form I-3B (PDPs)
Project Summary Information		
Project Name	GUAJOME LAKE	
Project Address	UNASSIGNED ON GUAJOME LAKE ROAD OCEANSIDE CA 92057	
Assessor's Parcel Number(s)	157-412-15-00	
Permit Application Number	T22-00004 / G22-00009 / DB22-00005	
Project Watershed (Hydrologic Unit)	Select One: <input type="checkbox"/> Santa Margarita 902 <input checked="" type="checkbox"/> San Luis Rey 903 <input type="checkbox"/> Carlsbad 904	
Parcel Area (total area of Assessor's Parcel(s) associated with the project)	<u>16.788</u> Acres (<u>731,283</u> Square Feet)	
Area to be disturbed by the project (Project Area w/ ROW)	<u>10.53</u> Acres (<u>458,900</u> Square Feet)	
Project Proposed Impervious Area (subset of Project Area)	<u>6.46</u> Acres (<u>281,300</u> Square Feet)	
Project Proposed Pervious Area (subset of Project Area)	<u>4.08</u> Acres (<u>177,600</u> Square Feet)	
Note: Proposed Impervious Area + Proposed Pervious Area = Area to be Disturbed by the Project. This may be less than the Parcel Area.		

Hydrologic Unit	Hydrologic Area	Hydrologic Sub-Area
Santa Margarita 902.00	<input type="checkbox"/> Ysidora 902.10	<input type="checkbox"/> Lower Ysidora 902.11
San Luis Rey 903.00	<input checked="" type="checkbox"/> Lower San Luis 903.10	<input checked="" type="checkbox"/> Mission 903.11
		<input type="checkbox"/> Bonsall 903.12
Carlsbad 904.00	<input type="checkbox"/> Loma Alta 904.10	Not Applicable
	<input type="checkbox"/> Buena Vista Creek 904.20	<input type="checkbox"/> El Salto 904.21
		<input type="checkbox"/> Vista 904.22
	<input type="checkbox"/> Agua Hedionda 4.30	<input type="checkbox"/> Los Monos 904.31



Description of Existing Site Condition and Drainage Patterns

Current Status of the Site (select all that apply):

- Existing development
- Previously graded but not built out
- Agricultural or other non-impervious use
- Vacant, undeveloped/natural

Description / Additional Information:

The existing site is mostly undeveloped with a large amount of sloping terrain across the site. There are a few existing structures toward the rear of the property. The existing site has a ridge line around the midpoint of the site with runoff sheet flowing to Guajome Lake road and toward developments adjacent to Seattle Slew Way.

Existing Land Cover Includes (select all that apply):

- Vegetative Cover
- Non-Vegetated Pervious Areas
- Impervious Areas

Description / Additional Information:

The existing site is mostly undeveloped and has natural vegetive cover throughout the site including Coastal Sage Scrub an a Southern Arroyo Willow Riparian Forest. The site also has a few existing structures along with an access road to them.

Underlying Soil belongs to Hydrologic Soil Group (select all that apply):

- NRCS Type A
- NRCS Type B
- NRCS Type C
- NRCS Type D

Approximate Depth to Groundwater:

- Groundwater Depth < 5 feet
- 5 feet < Groundwater Depth < 10 feet
- 10 feet < Groundwater Depth < 20 feet
- Groundwater Depth > 20 feet



Description of Existing Site Topography and Drainage [How is storm water runoff conveyed from the site? At a minimum, this description should answer (1) whether existing drainage conveyance is natural or urban; (2) describe existing constructed storm water conveyance systems, if applicable; and (3) is runoff from offsite conveyed through the site? If so, describe]:

Existing conditions are currently natural, overland sheet flow is the only drainage form onsite. Existing storm water conveyance systems are nonexistent on the existing site. Offsite runoff is not conveyed through the current site. Refer to the drainage report / hydrology study for the proposed development, analyzing existing and proposed conditions, included in Attachment 5 of this report.



Description of Proposed Site Development and Drainage Patterns

Project Description / Proposed Land Use and/or Activities:

The project proposes 83 new single-family lots that include the construction of a new private access road, associated utility, private lot drainage system along with storm drain backbone systems to route runoff to one of three proposed biofiltration basins for pollution treatment and hydromodification control. The project also proposes an open amenity space in the middle of the site.

List/describe proposed impervious features of the project (e.g., buildings, roadways, parking lots, courtyards, athletic courts, other impervious features):

Current impervious features of the project include:

Buildings and roof overhang areas, a new access road, driveways, additional walkways and hardscape. Concrete sidewalk and 35-ft wide paving of Guajome lake road along the frontage of the property to improve the road from the existing dirt road.

List/describe proposed pervious features of the project (e.g., landscape areas):

Landscaped areas are currently the only pervious features of the proposed project.

Does the project include grading and changes to site topography?

Yes

No

Description / Additional Information:

The entire site will be graded to create pads for the construction of single-family homes in accordance with the preliminary grading plan. The project proposes 84,500 CY of cut and 17,500 CY of fill resulting in 67,000 CY of export. While the site topography will change somewhat to promote the development of the homes, site historic drainage patterns will remain unchanged and the site will continue to direct the majority of runoff towards Guajome Lake Road and then into culverts on the south side of the road. A small portion of the site with drain toward the north similarly to the existing condition.



Does the project include changes to site drainage (e.g., installation of new storm water conveyance systems)?

Yes

No

Description / Additional Information:

Runoff from each lot will be directed from roofs to vegetated swales and then a series of area drains that will route runoff to the front of each lot. Runoff will then be piped through sidewalk underdrains to the proposed private road curb faces. Once in the private road runoff will continue in the curb and gutter until runoff reaches a curb inlet. From there runoff will be routed to one of the three proposed biofiltration basins. Lots that can not feasibly drain to the curb face will tie into the backbone storm drain system and will be routed directly to a biofiltration basin.



Identify whether any of the following features, activities, and/or pollutant source areas will be present (select all that apply):

- Onsite storm drain inlets
- Interior floor drains and elevator shaft sump pumps
- Interior parking garages
- Need for future indoor & structural pest control
- Landscape/outdoor pesticide use
- Pools, spas, ponds, decorative fountains, and other water features
- Food service
- Refuse areas
- Industrial processes
- Outdoor storage of equipment or materials
- Vehicle and equipment cleaning
- Vehicle/equipment repair and maintenance
- Fuel dispensing areas
- Loading docks
- Fire sprinkler test water
- Miscellaneous drain or wash water
- Plazas, sidewalks, and parking lots



Identification of Receiving Water Pollutants of Concern

Describe path of storm water from the project site to the Pacific Ocean (or bay, lagoon, lake or reservoir, as applicable):

The majority of storm water from the project site will travel south across Guajome Lake Road, through culverts and then down to a drainage channel on the north side of N Santa Fe Avenue, runoff will ultimately outlet into the Pacific Ocean.

List any 303(d) impaired water bodies within the path of storm water from the project site to the Pacific Ocean (or bay, lagoon, lake or reservoir, as applicable), identify the pollutant(s)/stressor(s) causing impairment, and identify any TMDLs for the impaired water bodies:

303(d) Impaired Water Body	Pollutant(s)/Stressor(s)	TMDLs
East Channel Creek (Northerly portion of project site)	Indicator Bacteria	
Guajome Lake	Eutophic	
San Luis River Lower	Indicator Bacteria Benthic Community Effects Bifenthrin Chloride Nirtogen Phosphorus Total Dissolved Solids Toxicity	
Pacific Ocean Shoreline, San Luis Rey HU		Indicator Bacteria



Identification of Project Site Pollutants*

***Identification of project site pollutants is only required if flow-thru treatment BMPs are implemented onsite in lieu of retention or biofiltration BMPs (note the project must also participate in an alternative compliance program unless prior lawful approval to meet earlier PDP requirements is demonstrated)**

Identify pollutants expected from the project site based on all proposed use(s) of the site (see manual Appendix B.6):

Pollutant	Not Applicable to the Project Site	Expected from the Project Site	Also a Receiving Water Pollutant of Concern
Sediment			
Nutrients			
Heavy Metals			
Organic Compounds			
Trash & Debris			
Oxygen Demanding Substances			
Oil & Grease			
Bacteria & Viruses			
Pesticides			

Note: Indicator Bacteria shall be addressed as a Pollutant of Concern (POC) for projects located in the Lower San Luis Hydrologic Area and for projects that discharge to the Pacific Ocean Shoreline within the boundaries of the City of Oceanside.

Note: Nutrients shall be addressed as a Pollutant of Concern (POC) for projects located in the Loma Alta Hydrologic Area.



Hydromodification Management Requirements

Do hydromodification management requirements apply (see Section 1.6 of the manual)?

- Yes, hydromodification management flow control structural BMPs required.
- No, the project will discharge runoff directly to existing underground storm drains discharging directly to water storage reservoirs, lakes, enclosed embayments, or the Pacific Ocean.
- No, the project will discharge runoff directly to conveyance channels whose bed and bank are concrete-lined all the way from the point of discharge to water storage reservoirs, lakes, enclosed embayments, or the Pacific Ocean.
- No, the project will discharge runoff directly to an area identified as appropriate for an exemption by the WMAA for the watershed in which the project resides.

Description / Additional Information (to be provided if a 'No' answer has been selected above):

Critical Coarse Sediment Yield Areas*

***This Section only required if hydromodification management requirements apply**

Based on the maps provided within the WMAA, do potential critical coarse sediment yield areas exist within the project drainage boundaries?

- Yes
- No, no critical coarse sediment yield areas to be protected based on WMAA maps

If yes, have any of the optional analyses presented in Section 6.2 of the manual been performed?

- 6.2.1 Verification of GLUs Onsite
- 6.2.2 Downstream Systems Sensitivity to Coarse Sediment
- 6.2.3 Optional Additional Analysis of Potential Critical Coarse Sediment Yield Areas Onsite
- No optional analyses performed, the project will avoid critical coarse sediment yield areas identified based on WMAA maps

If optional analyses were performed, what is the final result?

- No critical coarse sediment yield areas to be protected based on verification of GLUs onsite.
- Critical coarse sediment yield areas exist but additional analysis has determined that protection is not required. Documentation attached in Attachment 8 of the SWQMP.
- Critical coarse sediment yield areas exist and require protection. The project will implement management measures described in Sections 6.2.4 and 6.2.5 as applicable, and the areas are identified on the SWQMP Exhibit.

Discussion / Additional Information:

Using the methodology in the County of San Diego BMP Design Manual it was shown that PCCSYAs within the development and their removal will not negatively affect downstream receiving bodies refer to “Technical Memorandum: Analysis of PCCSYAs for Guajome Residential Project. Oceanside, CA.” prepared by REC Consultants dated November 23, 2021 and revised August 31, 2022



Flow Control for Post-Project Runoff*

***This Section only required if hydromodification management requirements apply**

List and describe point(s) of compliance (POCs) for flow control for hydromodification management (see Section 6.3.1). For each POC, provide a POC identification name or number correlating to the project's HMP Exhibit and a receiving channel identification name or number correlating to the project's HMP Exhibit.

There are two POCs on site POC-1 and POC-2. POC-1 on the West side and POC-2 on the East side both out letting on the south side of Guajome Lake Road and continuing to Guajome Lake RC-1. See map included in Attachment 2 of this report.

Has a geomorphic assessment been performed for the receiving channel(s)?

- No, the low flow threshold is 0.1Q2 (default low flow threshold)
- Yes, the result is the low flow threshold is 0.1Q2
- Yes, the result is the low flow threshold is 0.3Q2
- Yes, the result is the low flow threshold is 0.5Q2

If a geomorphic assessment has been performed, provide title, date, and preparer:

Discussion / Additional Information: (optional)



Other Site Requirements and Constraints

When applicable, list other site requirements or constraints that will influence storm water management design, such as zoning requirements including setbacks and open space, or local codes governing minimum street width, sidewalk construction, allowable pavement types, and drainage requirements.

Optional Additional Information or Continuation of Previous Sections As Needed

This space provided for additional information or continuation of information from previous sections as needed.



Source Control BMP Checklist for All Development Projects (Standard Projects and PDPs)		Form I-4	
Project Identification			
Project Name: GUAJOME LAKE			
Permit Application Number: T22-00004 / G22-00009 / DB22-00005			
Source Control BMPs			
All development projects must implement source control BMPs SC-1 through SC-6 where applicable and feasible. See Chapter 4 and Appendix E of the manual for information to implement source control BMPs shown in this checklist.			
Answer each category below pursuant to the following.			
<ul style="list-style-type: none"> • "Yes" means the project will implement the source control BMP as described in Chapter 4 and/or Appendix E of the manual. Discussion / justification is not required. • "No" means the BMP is applicable to the project but it is not feasible to implement. Discussion / justification must be provided. • "N/A" means the BMP is not applicable at the project site because the project does not include the feature that is addressed by the BMP (e.g., the project has no outdoor materials storage areas). Discussion / justification may be provided. 			
Source Control Requirement		Implemented?	
SC-1 Prevention of Illicit Discharges into the MS4		<input checked="" type="checkbox"/> Yes	<input type="checkbox"/> No <input type="checkbox"/> N/A
Discussion / justification if SC-1 not implemented:			
Lots will be equipped with effective irrigation and dispersion of non-storm water discharges into landscape for infiltration.			
SC-2 Storm Drain Stenciling or Signage		<input checked="" type="checkbox"/> Yes	<input type="checkbox"/> No <input type="checkbox"/> N/A
Discussion / justification if SC-2 not implemented:			
Proposed onsite storm drain inlets will be marked accordingly			
SC-3 Protect Outdoor Materials Storage Areas from Rainfall, Run-On, Runoff, and Wind Dispersal		<input type="checkbox"/> Yes	<input type="checkbox"/> No <input checked="" type="checkbox"/> N/A
Discussion / justification if SC-3 not implemented:			
Not applicable. No permanent outdoor materials storage areas proposed with this project.			



Source Control Requirement	Implemented?		
SC-4 Protect Materials Stored in Outdoor Work Areas from Rainfall, Run-On, Runoff, and Wind Dispersal	<input type="checkbox"/> Yes	<input type="checkbox"/> No	<input checked="" type="checkbox"/> N/A
Discussion / justification if SC-4 not implemented: Not applicable. No permanent materials stored in outdoor work areas to be protected.			
SC-5 Protect Trash Storage Areas from Rainfall, Run-On, Runoff, and Wind Dispersal	<input type="checkbox"/> Yes	<input type="checkbox"/> No	<input checked="" type="checkbox"/> N/A
Discussion / justification if SC-5 not implemented: Not applicable. No permanent outdoor trash storage areas to be protected.			



Form I-4 Page 3 of 3

SC-6 Additional BMPs Based on Potential Sources of Runoff Pollutants (must answer for each source listed below)	Implemented?		
	<input checked="" type="checkbox"/> Yes	<input type="checkbox"/> No	<input type="checkbox"/> N/A
Onsite storm drain inlets	<input checked="" type="checkbox"/> Yes	<input type="checkbox"/> No	<input type="checkbox"/> N/A
Interior floor drains and elevator shaft sump pumps	<input type="checkbox"/> Yes	<input type="checkbox"/> No	<input checked="" type="checkbox"/> N/A
Interior parking garages	<input type="checkbox"/> Yes	<input type="checkbox"/> No	<input checked="" type="checkbox"/> N/A
Need for future indoor & structural pest control	<input checked="" type="checkbox"/> Yes	<input type="checkbox"/> No	<input checked="" type="checkbox"/> N/A
Landscape/outdoor pesticide use	<input checked="" type="checkbox"/> Yes	<input type="checkbox"/> No	<input type="checkbox"/> N/A
Pools, spas, ponds, decorative fountains, and other water features	<input type="checkbox"/> Yes	<input type="checkbox"/> No	<input checked="" type="checkbox"/> N/A
Food service	<input type="checkbox"/> Yes	<input type="checkbox"/> No	<input checked="" type="checkbox"/> N/A
Refuse area	<input type="checkbox"/> Yes	<input type="checkbox"/> No	<input checked="" type="checkbox"/> N/A
Industrial processes	<input type="checkbox"/> Yes	<input type="checkbox"/> No	<input checked="" type="checkbox"/> N/A
Outdoor storage of equipment or materials	<input type="checkbox"/> Yes	<input type="checkbox"/> No	<input checked="" type="checkbox"/> N/A
Vehicle and equipment cleaning	<input type="checkbox"/> Yes	<input type="checkbox"/> No	<input checked="" type="checkbox"/> N/A
Vehicle/equipment repair and maintenance	<input type="checkbox"/> Yes	<input type="checkbox"/> No	<input checked="" type="checkbox"/> N/A
Fuel dispensing areas	<input type="checkbox"/> Yes	<input type="checkbox"/> No	<input checked="" type="checkbox"/> N/A
Loading docks	<input type="checkbox"/> Yes	<input type="checkbox"/> No	<input checked="" type="checkbox"/> N/A
Fire sprinkler test water	<input checked="" type="checkbox"/> Yes	<input type="checkbox"/> No	<input type="checkbox"/> N/A
Miscellaneous drain or wash water	<input type="checkbox"/> Yes	<input type="checkbox"/> No	<input checked="" type="checkbox"/> N/A
Plazas, sidewalks, and parking lots	<input type="checkbox"/> Yes	<input type="checkbox"/> No	<input checked="" type="checkbox"/> N/A
<p>Discussion / justification if SC-6 not implemented. Clearly identify which sources of runoff pollutants are discussed. Justification must be provided for <u>all</u> "No" answers shown above.</p>			



Site Design BMP Checklist for All Development Projects (Standard Projects and PDPs)	Form I-5
--	-----------------

Project Identification

Project Name: GUAJOME LAKE
 Permit Application Number: : T22-00004 / G22-00009 / DB22-00005

Site Design BMPs

All development projects must implement site design BMPs SD-1 through SD-8 where applicable and feasible. See Chapter 4 and Appendix E of the manual for information to implement site design BMPs shown in this checklist.

Answer each category below pursuant to the following.

- "Yes" means the project will implement the site design BMP as described in Chapter 4 and/or Appendix E of the manual. Discussion / justification is not required.
- "No" means the BMP is applicable to the project but it is not feasible to implement. Discussion / justification must be provided.
- "N/A" means the BMP is not applicable at the project site because the project does not include the feature that is addressed by the BMP (e.g., the project site has no existing natural areas to conserve). Discussion / justification may be provided.

Site Design Requirement	Applied?		
-------------------------	----------	--	--

SD-1 Maintain Natural Drainage Pathways and Hydrologic Features	<input checked="" type="checkbox"/> Yes	<input type="checkbox"/> No	<input type="checkbox"/> N/A
--	---	-----------------------------	------------------------------

Discussion / justification if SD-1 not implemented:
 The rear portion of the site will remained undisturbed and drainage will continue to follow its natural path. Runoff from the front of the site will not since the whole site will be regraded and there will be no natural drainage pathways remaining.

SD-2 Conserve Natural Areas, Soils, and Vegetation	<input checked="" type="checkbox"/> Yes	<input type="checkbox"/> No	<input type="checkbox"/> N/A
---	---	-----------------------------	------------------------------

Discussion / justification if SD-2 not implemented:
 The northerly portion of the site will remain on touched for southern arroyo willow riparian forest and coastal sage scrub areas

SD-3 Minimize Impervious Area	<input checked="" type="checkbox"/> Yes	<input type="checkbox"/> No	<input type="checkbox"/> N/A
--------------------------------------	---	-----------------------------	------------------------------

Discussion / justification if SD-3 not implemented:
 Building footprints have been designed to be more compact, open landscaped amenity space in the center of the site.

SD-4 Minimize Soil Compaction	<input checked="" type="checkbox"/> Yes	<input type="checkbox"/> No	<input type="checkbox"/> N/A
--------------------------------------	---	-----------------------------	------------------------------

Discussion / justification if SD-4 not implemented:
 Landscaped areas will be re-tilled to allow for higher infiltration capacities.



Site Design Requirement	Applied?		
SD-5 Impervious Area Dispersion	<input checked="" type="checkbox"/> Yes	<input type="checkbox"/> No	<input type="checkbox"/> N/A
Discussion / justification if SD-5 not implemented: Runoff reaching roof tops or hardscaped areas within each lot will be redirected to landscapes swales			
SD-6 Runoff Collection	<input checked="" type="checkbox"/> Yes	<input type="checkbox"/> No	<input type="checkbox"/> N/A
Discussion / justification if SD-6 not implemented: Each lot will have landscaped area that will allow for infiltration and will reduce the amount of runoff leaving the site.			
SD-7 Landscaping with Native or Drought Tolerant Species	<input checked="" type="checkbox"/> Yes	<input type="checkbox"/> No	<input type="checkbox"/> N/A
Discussion / justification if SD-7 not implemented: Plants selected for landscaping will be drought tolerant and will not require watering after establishment			
SD-8 Harvesting and Using Precipitation	<input type="checkbox"/> Yes	<input type="checkbox"/> No	<input checked="" type="checkbox"/> N/A
Discussion / justification if SD-8 not implemented: Anticipated 36 hour demand for harvest and use is less than 25% of DCV, therefore harvest and use is infeasible. See form I-7, harvest and use is infeasible. Due to long term maintenance concerns rain barrels have not been implemented to the site.			



Summary of PDP Structural BMPs	Form I-6 (PDPs)
Project Identification	
Project Name: GUAJOME LAKE	
Permit Application Number: : T22-00004 / G22-00009 / DB22-00005	
PDP Structural BMPs	
<p>All PDPs must implement structural BMPs for storm water pollutant control (see Chapter 5 of the manual). Selection of PDP structural BMPs for storm water pollutant control must be based on the selection process described in Chapter 5. PDPs subject to hydromodification management requirements must also implement structural BMPs for flow control for hydromodification management (see Chapter 6 of the manual). Both storm water pollutant control and flow control for hydromodification management can be achieved within the same structural BMP(s).</p>	
<p>PDP structural BMPs must be verified by the local jurisdiction at the completion of construction. This may include requiring the project owner or project owner's representative to certify construction of the structural BMPs (see Section 1.12 of the manual). PDP structural BMPs must be maintained into perpetuity, and the local jurisdiction must confirm the maintenance (see Section 7 of the manual).</p>	
<p>Use this form to provide narrative description of the general strategy for structural BMP implementation at the project site in the box below. Then complete the PDP structural BMP summary information sheet (page 3 of this form) for each structural BMP within the project (copy the BMP summary information page as many times as needed to provide summary information for each individual structural BMP).</p>	



Describe the general strategy for structural BMP implementation at the site. This information must describe how the steps for selecting and designing storm water pollutant control BMPs presented in Section 5.1 of the manual were followed, and the results (type of BMPs selected). For projects requiring hydromodification flow control BMPs, indicate whether pollutant control and flow control BMPs are integrated or separate.

The project site contains hydrologic soil groups A and D, but the portion that work will be done in only contains hydrologic soil group D. Using the City of Oceanside BMP Design Manual (COBDM) the sites rainfall depth was determined. After delineating the area that will reach each proposed BMP and calculating the runoff factor for the site the daily capture volume (DVC) for each proposed BMP was determined. Next the retention requirements for each BMP were determined using COBDM appendix B.2. The BMPs retention and pollutant control performance were determine using the County of San Diego automated sizing worksheets. The biofiltration basin detention and pollutant control performance per modeled using HydroCAD and SWMM respectively.

There are three BMP basins proposed for the project. They have approximately 13,582 square feet of surface area with BMP 1 having 8,045 square feet of area, BMP 2 has 4,500 square feet and BMP 3 has 1,037 square feet of area. BMP 1 is located along the southwestern corner of the site while BMP 2 is located along the southeastern corner and BMP 3 is located in the open space at the center of the site. The basin has no feasibility of infiltration and will be constructed as a biofiltration basin (BF-1), achieving pollutant treatment and hydromodification control design.

(Continue on page 2 as necessary.)



(Continued from page 1)



Structural BMP Summary Information

(Copy this page as needed to provide information for each individual proposed structural BMP)

Structural BMP ID No. BMP #1	
Construction Plan Sheet No.	
Type of structural BMP: <input type="checkbox"/> Retention by harvest and use (HU-1) <input type="checkbox"/> Retention by infiltration basin (INF-1) <input type="checkbox"/> Retention by bioretention (INF-2) <input type="checkbox"/> Retention by permeable pavement (INF-3) <input type="checkbox"/> Partial retention by biofiltration with partial retention (PR-1) <input checked="" type="checkbox"/> Biofiltration (BF-1) <input type="checkbox"/> Flow-thru treatment control with prior lawful approval to meet earlier PDP requirements (provide BMP type/description in discussion section below) <input type="checkbox"/> Flow-thru treatment control included as pre-treatment/forebay for an onsite retention or biofiltration BMP (provide BMP type/description and indicate which onsite retention or biofiltration BMP it serves in discussion section below) <input type="checkbox"/> Flow-thru treatment control with alternative compliance (provide BMP type/description in discussion section below) <input type="checkbox"/> Detention pond or vault for hydromodification management <input type="checkbox"/> Other (describe in discussion section below)	
Purpose: <input type="checkbox"/> Pollutant control only <input type="checkbox"/> Hydromodification control only <input checked="" type="checkbox"/> Combined pollutant control and hydromodification control <input type="checkbox"/> Pre-treatment/forebay for another structural BMP <input type="checkbox"/> Other (describe in discussion section below)	
Who will certify construction of this BMP? Provide name and contact information for the party responsible to sign BMP verification forms if required by the [City Engineer] (See Section 1.12 of the manual)	Tyler Lawson Associate Principal Pasco, Laret, Suiter and Associates (PLSA)
Who will be the final owner of this BMP?	Guajome Lake HOA
Who will maintain this BMP into perpetuity?	Guajome Lake HOA
What is the funding mechanism for maintenance?	Guajome Lake HOA



Structural BMP Summary Information

(Copy this page as needed to provide information for each individual proposed structural BMP)

Discussion (as needed):



Structural BMP Summary Information

(Copy this page as needed to provide information for each individual proposed structural BMP)

Structural BMP ID No. BMP #2	
Construction Plan Sheet No.	
Type of structural BMP: <input type="checkbox"/> Retention by harvest and use (HU-1) <input type="checkbox"/> Retention by infiltration basin (INF-1) <input type="checkbox"/> Retention by bioretention (INF-2) <input type="checkbox"/> Retention by permeable pavement (INF-3) <input type="checkbox"/> Partial retention by biofiltration with partial retention (PR-1) <input checked="" type="checkbox"/> Biofiltration (BF-1) <input type="checkbox"/> Flow-thru treatment control with prior lawful approval to meet earlier PDP requirements (provide BMP type/description in discussion section below) <input type="checkbox"/> Flow-thru treatment control included as pre-treatment/forebay for an onsite retention or biofiltration BMP (provide BMP type/description and indicate which onsite retention or biofiltration BMP it serves in discussion section below) <input type="checkbox"/> Flow-thru treatment control with alternative compliance (provide BMP type/description in discussion section below) <input type="checkbox"/> Detention pond or vault for hydromodification management <input type="checkbox"/> Other (describe in discussion section below)	
Purpose: <input type="checkbox"/> Pollutant control only <input type="checkbox"/> Hydromodification control only <input checked="" type="checkbox"/> Combined pollutant control and hydromodification control <input type="checkbox"/> Pre-treatment/forebay for another structural BMP <input type="checkbox"/> Other (describe in discussion section below)	
Who will certify construction of this BMP? Provide name and contact information for the party responsible to sign BMP verification forms if required by the [City Engineer] (See Section 1.12 of the manual)	Tyler Lawson Associate Principal Pasco, Laret, Suiter and Associates (PLSA)
Who will be the final owner of this BMP?	Guajome Lake HOA
Who will maintain this BMP into perpetuity?	Guajome Lake HOA
What is the funding mechanism for maintenance?	Guajome Lake HOA



Structural BMP Summary Information

(Copy this page as needed to provide information for each individual proposed structural BMP)

Discussion (as needed):



Structural BMP Summary Information

(Copy this page as needed to provide information for each individual proposed structural BMP)

Structural BMP ID No. BMP #3	
Construction Plan Sheet No.	
Type of structural BMP: <input type="checkbox"/> Retention by harvest and use (HU-1) <input type="checkbox"/> Retention by infiltration basin (INF-1) <input type="checkbox"/> Retention by bioretention (INF-2) <input type="checkbox"/> Retention by permeable pavement (INF-3) <input type="checkbox"/> Partial retention by biofiltration with partial retention (PR-1) <input checked="" type="checkbox"/> Biofiltration (BF-1) <input type="checkbox"/> Flow-thru treatment control with prior lawful approval to meet earlier PDP requirements (provide BMP type/description in discussion section below) <input type="checkbox"/> Flow-thru treatment control included as pre-treatment/forebay for an onsite retention or biofiltration BMP (provide BMP type/description and indicate which onsite retention or biofiltration BMP it serves in discussion section below) <input type="checkbox"/> Flow-thru treatment control with alternative compliance (provide BMP type/description in discussion section below) <input type="checkbox"/> Detention pond or vault for hydromodification management <input type="checkbox"/> Other (describe in discussion section below)	
Purpose: <input type="checkbox"/> Pollutant control only <input type="checkbox"/> Hydromodification control only <input checked="" type="checkbox"/> Combined pollutant control and hydromodification control <input type="checkbox"/> Pre-treatment/forebay for another structural BMP <input type="checkbox"/> Other (describe in discussion section below)	
Who will certify construction of this BMP? Provide name and contact information for the party responsible to sign BMP verification forms if required by the [City Engineer] (See Section 1.12 of the manual)	Tyler Lawson Associate Principal Pasco, Laret, Suiter and Associates (PLSA)
Who will be the final owner of this BMP?	Guajome Lake HOA
Who will maintain this BMP into perpetuity?	Guajome Lake HOA
What is the funding mechanism for maintenance?	Guajome Lake HOA





City of Oceanside
 300 N Coast Highway
 Oceanside, CA 92054

**Permanent BMP
 Construction
 Self Certification Form**

February
 2016

Date Prepared: 4/4/24	Project No.: : T22-00005 / G22-00009 / DB22-00004
Project Applicant: Rincon Homes Inc.	Phone: (888)357-3553
Project Address: Unassigned on Guajome Lake Road, Oceanside, CA 92057	
Project Engineer: Tyler Lawson	Phone: (858)259-8212
<p>The purpose of this form is to verify that the site improvements for the project, identified above, have been constructed in conformance with the approved Storm Water Quality Management Plan (SWQMP) documents and drawings.</p> <p>This form must be completed by the engineer and installing contractor and submitted prior to final inspection of the construction permit. Completion and submittal of this form is required for all new development and redevelopment projects in order to comply with the City's Storm Water ordinances and NDPEs Permit Order No. R9-2013-0001. Final inspection for occupancy and/or release of grading or public improvement bonds may be delayed if this form is not submitted and approved by the City of Oceanside.</p>	
<p>ENGINEER'S CERTIFICATION:</p> <p>As the professional in responsible charge for the design of the above project, I certify that I have inspected all constructed Low Impact Development (LID) site design, source control and treatment control BMP's required per the approved SWQMP and Construction Permit No. Click here to enter text.; and that said BMP's have been constructed in compliance with the approved plans and all applicable specifications, permits, ordinances and Order No. R9-2013-0001 of the San Diego Regional Water Quality Control Board.</p> <p>I understand that this BMP certification statement does not constitute an operation and maintenance verification.</p> <p>Signature: _____</p>	



Date of Signature: _____

Printed Name: Tyler Lawson

Title: Professional Engineer

Phone No. (858)259-8212 _____

Engineer's Stamp

CONTRACTOR'S CERTIFICATION:

As the professional in responsible charge for construction of the above project, I certify that all constructed Low Impact Development (LID) site design, source control and treatment control BMP's required per the approved SWQMP and Construction Permit No. [Click here to enter text.](#); have been constructed in compliance with the approved plans and all applicable specifications, permits, and ordinances.

I understand that this BMP certification statement does not constitute an operation and maintenance verification.

Signature: _____

Date of Signature: _____

Printed Name: _____

Title: _____

Phone No. _____



ATTACHMENT 1
BACKUP FOR PDP POLLUTANT CONTROL BMPS

This is the cover sheet for Attachment 1.



Indicate which Items are Included:

Attachment Sequence	Contents	Checklist
Attachment 1a	DMA Exhibit (Required) See DMA Exhibit Checklist.	<input checked="" type="checkbox"/> Included
Attachment 1b	Tabular Summary of DMAs Showing DMA ID matching DMA Exhibit, DMA Area, and DMA Type (Required)* *Provide table in this Attachment OR on DMA Exhibit in Attachment 1a	<input checked="" type="checkbox"/> Included on DMA Exhibit in Attachment 1a <input type="checkbox"/> Included as Attachment 1b, separate from DMA Exhibit
Attachment 1c	Design Capture Volume Worksheet	<input checked="" type="checkbox"/> Included
Attachment 1d	Form I-7, Harvest and Use Feasibility Screening Checklist (Required unless the entire project will use infiltration BMPs) Refer to Appendix B.3-1 of the BMP Design Manual to complete Form I-7.	<input checked="" type="checkbox"/> Included <input type="checkbox"/> Not included because the entire project will use infiltration BMPs
Attachment 1e	Form I-8, Categorization of Infiltration Feasibility Condition (Required unless the project will use harvest and use BMPs) Refer to Appendices C and D of the BMP Design Manual to complete Form I-8.	<input checked="" type="checkbox"/> Included <input type="checkbox"/> Not included because the entire project will use harvest and use BMPs
Attachment 1f	Pollutant Control BMP Design Worksheets / Calculations (Required) Refer to Appendices B and E of the BMP Design Manual for structural pollutant control BMP design guidelines	<input checked="" type="checkbox"/> Included



Use this checklist to ensure the required information has been included on the DMA Exhibit:

The DMA Exhibit must identify:

- Underlying hydrologic soil group
- Approximate depth to groundwater
- Existing natural hydrologic features (watercourses, seeps, springs, wetlands)
- Critical coarse sediment yield areas to be protected
- Existing topography and impervious areas
- Existing and proposed site drainage network and connections to drainage offsite
- Proposed grading
- Proposed impervious features
- Proposed design features and surface treatments used to minimize imperviousness
- Drainage management area (DMA) boundaries, DMA ID numbers, and DMA areas (square footage or acreage), and DMA type (i.e., drains to BMP, self-retaining, or self-mitigating)
- Potential pollutant source areas and corresponding required source controls (see Chapter 4, Appendix E.1, and Form I-3B)
- Structural BMPs (identify location, type of BMP, and size/detail)



Placeholder – **Tabular Summary of DMAs (if separate from DMA Exhibit)**

Leave placeholder intact if not applicable.

Not Applicable – Tabular Summary included on DMA Exhibit



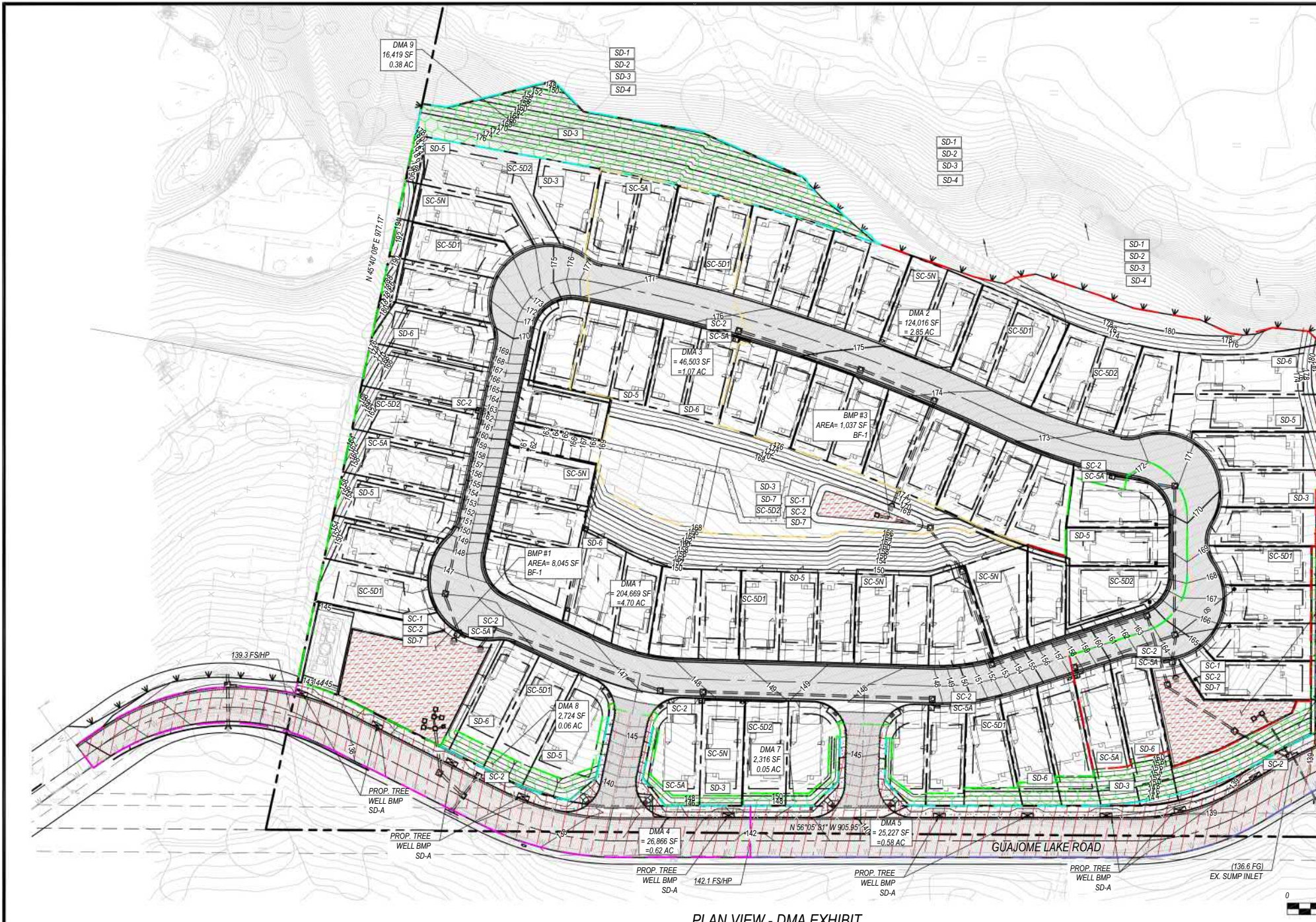

LEGEND

- PROPERTY LINE
- RIGHT-OF-WAY
- CENTERLINE OF ROAD
- EXISTING CONTOUR LINE
- PROPOSED CONTOUR LINE
- FLOW DIRECTION
- PROPOSED DMA 1 BOUNDARY
- PROPOSED DMA 2 BOUNDARY
- PROPOSED DMA 3 BOUNDARY
- PROPOSED DMA 4 BOUNDARY
- PROPOSED DMA 5 BOUNDARY
- PROPOSED SELF-MITIGATING DMA BOUNDARY PER SECTION 5.2.1 OF OCEANSIDE BMP DESIGN MANUAL
- PROPOSED SELF-MITIGATING DMA PER SECTION 5.2.1 OF OCEANSIDE BMP DESIGN MANUAL
- PROPOSED IMPERVIOUS AREA TO BE ROUTED TO TREE WELL BMPs OR COMPARABLE LID BMP FOR TREATMENT PER GREEN STREET STANDARDS
- PROPOSED BIOFILTRATION BASIN
- PROPOSED TREE WELL BMP (4' X 10')

DMA	DMA TABLE BMP	AREA (SF)
1	BIOFILTRATION (BF-1) BMP 1	204,669
2	BIOFILTRATION (BF-1) BMP 2	124,016
3	BIOFILTRATION (BF-1) BMP 3	46,503
4	TREE WELL (SD-1)	26,886
5	TREE WELL (SD-1)	25,227
6	SELF-MITIGATING	10,160
7	SELF-MITIGATING	2,316
8	SELF-MITIGATING	2,724
9	SELF-MITIGATING	16,419
TOTAL		458,900

BMP LEGEND

- | | |
|--|--|
| POST-CONSTRUCTION SITE DESIGN BMPs | POST-CONSTRUCTION SITE DESIGN BMPs |
| SD-1 MAINTAIN NATURAL DRAINAGE PATHWAYS AND HYDROLOGIC FEATURES | SC-1 PREVENTION OF ILLICIT DISCHARGE INTO THE MS4 |
| SD-2 CONSERVE NATURAL AREAS, SOILS AND VEGETATION | SC-2 STORM DRAIN STENCILING AND POSTING OF SIGNAGE |
| SD-3 MINIMIZE IMPERVIOUS AREA | SC-3 ADDITIONAL BMPs BASED ON POTENTIAL RUNOFF POLLUTANTS |
| SD-4 MINIMIZE SOIL COMPACTION | A ONSITE STARDOM DRAIN INLET |
| SD-5 IMPERVIOUS AREA DISPERSION | B NEED FOR FUTURE INDOOR & STR. PEST CONTROL |
| SD-6 RUNOFF COLLECTION | C LANDSCAPE / OUTDOOR PESTICIDE USE |
| SD-7 LANDSCAPING WITH NATIVE OR DROUGHT TOLERANT SPECIES | D FIRE SPRINKLER TEST WATER |
| SD-8 HARVESTING AND USE PERCIPITATION | |

PLAN VIEW - DMA EXHIBIT
SCALE: 1" = 50'

SOIL TYPE INFORMATION
SOIL: TYPE D HYDROLOGIC SOILS PER WEB SOIL SURVEY APPLICATION AVAILABLE THROUGH UNITED STATES DEPARTMENT OF AGRICULTURE

COARSE SEDIMENT YIELD
NO CRITICAL COARSE SEDIMENT YIELD AREAS TO BE PROTECTED. REFER TO PRIORITY DEVELOPMENT PROJECT SWQMP PREPARED BY PASCO, LARET, SUITER AND ASSOCIATES; SEE APPENDIX 2 "ANALYSIS OF PCCSYAs FOR GUAJOME RESIDENTIAL PROJECT, OCEANSIDE, CA." PREPARED BY REC CONSULTANTS, DATED NOVEMBER 23, 2021; REVISED AUGUST 31, 2022

GROUNDWATER INFORMATION
GROUND WATER DEPTH IS GREATER THAN 20 FEET.

TREATMENT CONTROL BMPs

BIOFILTRATION	BF-1
TREE WELL	SD-1

GUAJOME LAKE HOMES
OCEANSIDE, CA
DMA EXHIBIT ATT_1A



PREPARED BY:
PASCO LARET SUITER & ASSOCIATES
San Diego | Encinitas | Orange County
Phone 858.259.8212 | www.plsengineering.com

DMA 1 - AREA CALCULATIONS

IMPERVIOUS AREA (BUILDING/ROOF (PRIVATE DRIVE) (DRIVEWAYS) (MISC HARDSCAPE) (FUTURE CONTINGENCY) TOTAL	68,107 SF 37,506 SF 10,914 SF 1,589 SF 6,600 SF 124,716 SF
PERVIOUS AREA (LANDSCAPED AREA) (BIOFILTRATION BASIN) (FUTURE CONTINGENCY) TOTAL	78,508 SF 8,045 SF -6,600 SF 79,953 SF
TOTAL BASIN AREA	204,669 SF
%IMPERVIOUS	57.7%

*FUTURE HARDSCAPE CONTINGENCY BASED ON 150 SF OF IMPERVIOUS AREA PER LOT FOR FUTURE IMPROVEMENTS.

DMA 1 - DCV CALCULATIONS

AREA TRIBUTARY TO BMP (A)	= 204,669 SF / 4.70 AC
TOTAL DMA SIZE (C ^x A ^x)	= 132,270 SF / 3.04 AC
WEIGHTED RUNOFF FACTOR (C _x)	= 0.65
85TH PERCENTILE RAINFALL DEPTH (d)	= 0.67 INCHES
DCV (C ^x A ^x 3,630)	= 7,385 CU FT

DMA 2 - AREA CALCULATIONS

IMPERVIOUS AREA (BUILDING/ROOF (PRIVATE DRIVE) (ACCESS ROAD) (DRIVEWAYS) (MISC HARDSCAPE) (*15% FUTURE CONTINGENCY) TOTAL	48,182 SF 22,240 SF 1,298 SF 8,462 SF 1,177 SF 4,650 SF 86,009 SF
PERVIOUS AREA (LANDSCAPED AREA) (BIOFILTRATION BASIN) (*15% FUTURE CONTINGENCY) TOTAL	38,157 SF 4,500 SF -4,650 SF 38,007 SF
TOTAL BASIN AREA	124,016 SF
%IMPERVIOUS	65.6%

*FUTURE HARDSCAPE CONTINGENCY BASED ON 150 SF OF IMPERVIOUS AREA PER LOT FOR FUTURE IMPROVEMENTS.

DMA 2 - DCV CALCULATIONS

AREA TRIBUTARY TO BMP (A)	= 124,016 SF / 2.85 AC
TOTAL DMA SIZE (C ^x A ^x)	= 86,020 SF / 1.97 AC
WEIGHTED RUNOFF FACTOR (C _x)	= 0.69
85TH PERCENTILE RAINFALL DEPTH (d)	= 0.67 INCHES
DCV (C ^x A ^x 3,630)	= 4,803 CU FT

DMA 3 - AREA CALCULATIONS

IMPERVIOUS AREA (BUILDING/ROOF (PRIVATE DRIVE) (DRIVEWAYS) (OPEN SPACE HARDSCAPE) (MISC HARDSCAPE) (FUTURE CONTINGENCY) TOTAL	12,418 SF 4,801 SF 1,694 SF 2,263 SF 314 SF 1,200 SF 22,690 SF
PERVIOUS AREA (LANDSCAPED AREA) (BIOFILTRATION BASIN) (FUTURE CONTINGENCY) TOTAL	24,690 SF 1,000 SF -1,200 SF 23,813 SF
TOTAL BASIN AREA	46,503 SF
%IMPERVIOUS	46.2%

*FUTURE HARDSCAPE CONTINGENCY BASED ON 150 SF OF IMPERVIOUS AREA PER LOT FOR FUTURE IMPROVEMENTS.

DMA / BMP	AREA (SF)	POST-PROJECT SURFACE TYPE	SURFACE RUNOFF FACTOR	ADJUSTMENT FACTOR	AREA X ADJUSTED RUNOFF (SF)
A1	1,628	LOT 1 BUILDING	0.9	1	1,465
A2	189	LOT 1 DRIVEWAY	0.9	1	170
A3	43	LOT 1 HARDSCAPE	0.9	1	39
A4	1,573	LOT 2 BUILDING	0.9	1	1,416
A5	227	LOT 2 DRIVEWAY	0.9	1	204
A6	26	LOT 2 HARDSCAPE	0.9	1	23
A7	1,573	LOT 3 BUILDING	0.9	1	1,416
A8	227	LOT 3 DRIVEWAY	0.9	1	204
A9	26	LOT 3 HARDSCAPE	0.9	1	23
A10	1,628	LOT 4 BUILDING	0.9	1	1,465
A11	189	LOT 4 DRIVEWAY	0.9	1	170
A12	43	LOT 4 HARDSCAPE	0.9	1	39
A13	1,573	LOT 5 BUILDING	0.9	1	1,416
A14	227	LOT 5 DRIVEWAY	0.9	1	204
A15	26	LOT 5 HARDSCAPE	0.9	1	23
A16	1,380	LOT 6 BUILDING	0.9	1	1,242
A17	242	LOT 6 DRIVEWAY	0.9	1	218
A18	45	LOT 6 HARDSCAPE	0.9	1	41
A19	1,573	LOT 7 BUILDING	0.9	1	1,416
A20	227	LOT 7 DRIVEWAY	0.9	1	204
A21	26	LOT 7 HARDSCAPE	0.9	1	23
A22	1,380	LOT 8 BUILDING	0.9	1	1,242
A23	242	LOT 8 DRIVEWAY	0.9	1	218
A24	45	LOT 8 HARDSCAPE	0.9	1	41
A25	1,573	LOT 9 BUILDING	0.9	1	1,416
A26	227	LOT 9 DRIVEWAY	0.9	1	204
A27	26	LOT 9 HARDSCAPE	0.9	1	23
A28	1,628	LOT 10 BUILDING	0.9	1	1,465
A29	189	LOT 10 DRIVEWAY	0.9	1	170
A30	43	LOT 10 HARDSCAPE	0.9	1	39
A31	1,380	LOT 11 BUILDING	0.9	1	1,242
A32	242	LOT 11 DRIVEWAY	0.9	1	218
A33	45	LOT 11 HARDSCAPE	0.9	1	41
A34	1,573	LOT 12 BUILDING	0.9	1	1,416
A35	227	LOT 12 DRIVEWAY	0.9	1	204
A36	26	LOT 12 HARDSCAPE	0.9	1	23
A37	1,628	LOT 13 BUILDING	0.9	1	1,465
A38	189	LOT 13 DRIVEWAY	0.9	1	170
A39	43	LOT 13 HARDSCAPE	0.9	1	39
A40	1,380	LOT 14 BUILDING	0.9	1	1,242
A41	242	LOT 14 DRIVEWAY	0.9	1	218
A42	45	LOT 14 HARDSCAPE	0.9	1	41
A43	1,573	LOT 15 BUILDING	0.9	1	1,416
A44	227	LOT 15 DRIVEWAY	0.9	1	204
A45	26	LOT 15 HARDSCAPE	0.9	1	23
A46	1,628	LOT 16 BUILDING	0.9	1	1,465
A47	189	LOT 16 DRIVEWAY	0.9	1	170
A48	43	LOT 16 HARDSCAPE	0.9	1	39
A49	1,573	LOT 17 BUILDING	0.9	1	1,416
A50	649	LOT 17 DRIVEWAY	0.9	1	584
A51	26	LOT 17 HARDSCAPE	0.9	1	23
A52	1,628	LOT 18 BUILDING	0.9	1	1,465
A53	1,113	LOT 18 DRIVEWAY	0.9	1	1,002
A54	43	LOT 18 HARDSCAPE	0.9	1	39
A55	1,573	LOT 19 BUILDING	0.9	1	1,416
A56	227	LOT 19 DRIVEWAY	0.9	1	204
A57	26	LOT 19 HARDSCAPE	0.9	1	23
A58	1,380	LOT 20 BUILDING	0.9	1	1,242
A59	242	LOT 20 DRIVEWAY	0.9	1	218
A60	45	LOT 20 HARDSCAPE	0.9	1	41
A61	1,573	LOT 21 BUILDING	0.9	1	1,416
A62	227	LOT 21 DRIVEWAY	0.9	1	204
A63	26	LOT 21 HARDSCAPE	0.9	1	23
A64	1,628	LOT 22 BUILDING	0.9	1	1,465
A65	189	LOT 22 DRIVEWAY	0.9	1	170
A66	43	LOT 22 HARDSCAPE	0.9	1	39

A67	1,573	LOT 23 BUILDING	0.9	1	1,416
A68	227	LOT 23 DRIVEWAY	0.9	1	204
A69	26	LOT 23 HARDSCAPE	0.9	1	23
A70	1,380	LOT 24 BUILDING	0.9	1	1,242
A71	242	LOT 24 DRIVEWAY	0.9	1	218
A72	45	LOT 24 HARDSCAPE	0.9	1	41
A73	1,573	LOT 25 BUILDING	0.9	1	1,416
A74	227	LOT 25 DRIVEWAY	0.9	1	204
A75	26	LOT 25 HARDSCAPE	0.9	1	23
A76	1,628	LOT 26 BUILDING	0.9	1	1,465
A77	189	LOT 26 DRIVEWAY	0.9	1	170
A78	43	LOT 26 HARDSCAPE	0.9	1	39
A79	1,380	LOT 27 BUILDING	0.9	1	1,242
A80	242	LOT 27 DRIVEWAY	0.9	1	218
A81	45	LOT 27 HARDSCAPE	0.9	1	41
A82	1,573	LOT 28 BUILDING	0.9	1	1,416
A83	227	LOT 28 DRIVEWAY	0.9	1	204
A84	26	LOT 28 HARDSCAPE	0.9	1	23
A85	1,628	LOT 29 BUILDING	0.9	1	1,465
A86	189	LOT 29 DRIVEWAY	0.9	1	170
A87	43	LOT 29 HARDSCAPE	0.9	1	39
A88	1,380	LOT 30 BUILDING	0.9	1	1,242
A89	242	LOT 30 DRIVEWAY	0.9	1	218
A90	45	LOT 30 HARDSCAPE	0.9	1	41
A91	1,573	LOT 31 BUILDING	0.9	1	1,416
A92	227	LOT 31 DRIVEWAY	0.9	1	204
A93	26	LOT 31 HARDSCAPE	0.9	1	23
A94	1,628	LOT 32 BUILDING	0.9	1	1,465
A95	189	LOT 32 DRIVEWAY	0.9	1	170
A96	43	LOT 32 HARDSCAPE	0.9	1	39
A97	1,380	LOT 33 BUILDING	0.9	1	1,242
A98	242	LOT 33 DRIVEWAY	0.9	1	218
A99	45	LOT 33 HARDSCAPE	0.9	1	41
A100	1,573	LOT 34 BUILDING	0.9	1	1,416
A101	227	LOT 34 DRIVEWAY	0.9	1	204
A102	26	LOT 34 HARDSCAPE	0.9	1	23
A103	1,628	LOT 35 BUILDING	0.9	1	1,465
A104	189	LOT 35 DRIVEWAY	0.9	1	170
A105	43	LOT 35 HARDSCAPE	0.9	1	39
A106	1,573	LOT 36 BUILDING	0.9	1	1,416
A107	227	LOT 36 DRIVEWAY	0.9	1	204
A108	26	LOT 36 HARDSCAPE	0.9	1	23
A109	1,380	LOT 37 BUILDING	0.9	1	1,242
A110	242	LOT 37 DRIVEWAY	0.9	1	218
A111	45	LOT 37 HARDSCAPE	0.9	1	41
A112	1,628	LOT 38 BUILDING	0.9	1	1,465
A113	189	LOT 38 DRIVEWAY	0.9	1	170
A114	43	LOT 38 HARDSCAPE	0.9	1	39
A115	1,573	LOT 39 BUILDING	0.9	1	1,416
A116	227	LOT 39 DRIVEWAY	0.9	1	204
A117	26	LOT 39 HARDSCAPE	0.9	1	23
A118	1,628	LOT 40 BUILDING	0.9	1	1,465
A119	189	LOT 40 DRIVEWAY	0.9	1	170
A120	43	LOT 40 HARDSCAPE	0.9	1	39
A121	1,573	LOT 41 BUILDING	0.9	1	1,416
A122	227	LOT 41 DRIVEWAY	0.9	1	204
A123	26	LOT 41 HARDSCAPE	0.9	1	23
A124	1,628	LOT 42 BUILDING	0.9	1	1,465
A125	189	LOT 42 DRIVEWAY	0.9	1	170
A126	43	LOT 42 HARDSCAPE	0.9	1	39
A127	1,573	LOT 43 BUILDING	0.9	1	1,416
A128	227	LOT 43 DRIVEWAY	0.9	1	204
A129	26	LOT 43 HARDSCAPE	0.9	1	23
A130	1,628	LOT 44 BUILDING	0.9	1	1,465
A131	189	LOT 44 DRIVEWAY	0.9	1	170
A132	43	LOT 44 HARDSCAPE	0.9	1	39
A133	37,506	PRIVATE DRIVE	0.9	1	33,755
A134	78,508	LANDSCAPE	0.3	1	23,552
A135	8,045	BMP	0.3	1	2,414
TOTAL					132,270

DMA / BMP	AREA (SF)	POST-PROJECT SURFACE TYPE	SURFACE RUNOFF FACTOR	ADJUSTMENT FACTOR	AREA X ADJUSTED RUNOFF (SF)
B1	1,573	LOT 24 BUILDING	0.9	1	1,416
B2	227	LOT 24 DRIVEWAY	0.9	1	204
B3	26	LOT 24 HARDSCAPE	0.9	1	23
B4	1,628	LOT 25 BUILDING	0.9	1	1,465
B5	189	LOT 25 DRIVEWAY	0.9	1	170
B6	43	LOT 25 HARDSCAPE	0.9	1	39
B7	1,380	LOT 26 BUILDING	0.9	1	1,242
B8	242	LOT 26 DRIVEWAY	0.9	1	218
B9	45	LOT 26 HARDSCAPE	0.9	1	41
B10	1,628	LOT 27 BUILDING	0.9	1	1,465
B11	189	LOT 27 DRIVEWAY	0.9	1	170
B12	43	LOT 27 HARDSCAPE	0.9	1	39
B13	1,573	LOT 28 BUILDING	0.9	1	1,416
B14	227	LOT 28 DRIVEWAY	0.9	1	204
B15	26	LOT 28 HARDSCAPE	0.9	1	23
B16	1,628	LOT 29 BUILDING	0.9	1	1,465
B17	189	LOT 29 DRIVEWAY	0.9	1	170
B18	43	LOT 29 HARDSCAPE	0.9	1	39
B19	1,573	LOT 30 BUILDING	0.9	1	1,416
B20	227	LOT 30 DRIVEWAY	0.9	1	204
B21	26	LOT 30 HARDSCAPE	0.9	1	23
B22	1,628	LOT 31 BUILDING	0.9	1	1,465
B23	189	LOT 31 DRIVEWAY	0.9	1	170
B24	43	LOT 31 HARDSCAPE	0.9	1	39
B25	1,573	LOT 32 BUILDING	0.9	1	1,416
B26	227	LOT 32 DRIVEWAY	0.9	1	204
B27	26	LOT 32 HARDSCAPE	0.9	1	23
B28	1,628	LOT 33 BUILDING	0.9	1	1,465
B29	189	LOT 33 DRIVEWAY	0.9	1	170
B30	43	LOT 33 HARDSCAPE	0.9	1	39
B31	1,380	LOT 34 BUILDING	0.9	1	1,242
B32	242	LOT 34 DRIVEWAY	0.9	1	218
B33	45	LOT 34 HARDSCAPE	0.9	1	41
B34	1,628	LOT 35 BUILDING	0.9	1	1,465
B35	861	LOT 35 DRIVEWAY	0.9	1	775
B36	43	LOT 35 HARDSCAPE	0.9	1	39
B37	1,573	LOT 36 BUILDING	0.9	1	1,416
B38	1,012	LOT 36 DRIVEWAY	0.9	1	911
B39	26	LOT 36 HARDSCAPE	0.9	1	23
B40	1,628	LOT 37 BUILDING	0.9	1	1,465
B41	189	LOT 37 DRIVEWAY	0.9	1	170
B42	43	LOT 37 HARDSCAPE	0.9	1	39
B43	1,380	LOT 38 BUILDING	0.9	1	1,242
B44	242	LOT 38 DRIVEWAY	0.9	1	218
B45	45	LOT 38 HARDSCAPE	0.9	1	41
B46	1,628	LOT 39 BUILDING	0.9	1	1,465
B47	189	LOT 39 DRIVEWAY	0.9	1	170
B48	43	LOT 39 HARDSCAPE	0.9	1	39
B49	1,573	LOT 40 BUILDING	0.9	1	1,416
B50	227	LOT 40 DRIVEWAY	0.9	1	204
B51	26	LOT 40 HARDSCAPE	0.9	1	23
TOTAL					86,020

B52	1,380	LOT 41 BUILDING	0.9	1	1,2
-----	-------	-----------------	-----	---	-----

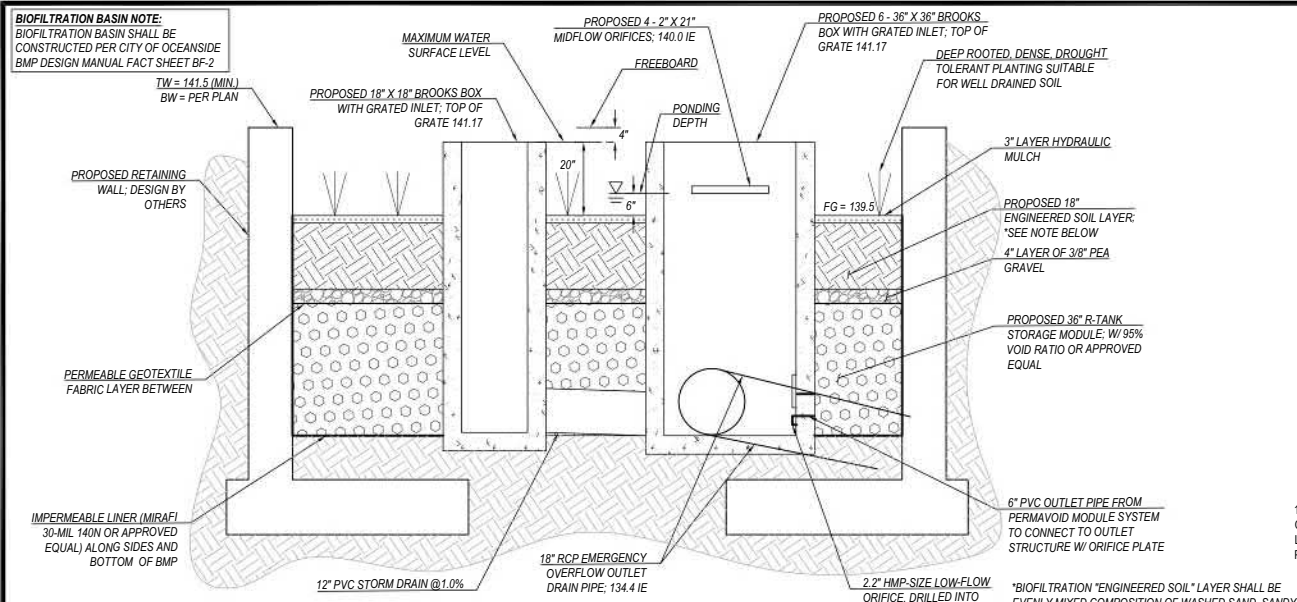

TYPICAL DETAIL - BMP 1 BIOFILTRATION BASIN
SCALE: NTS

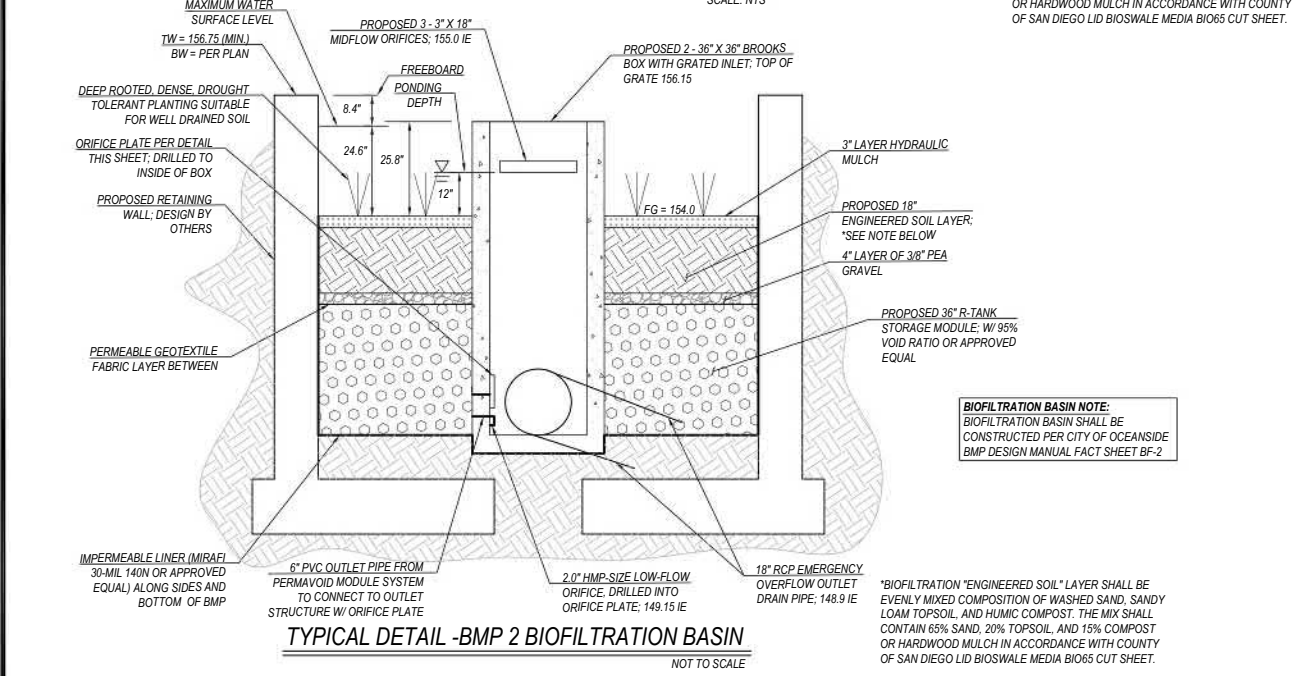

TYPICAL DETAIL - BMP 2 BIOFILTRATION BASIN
NOT TO SCALE

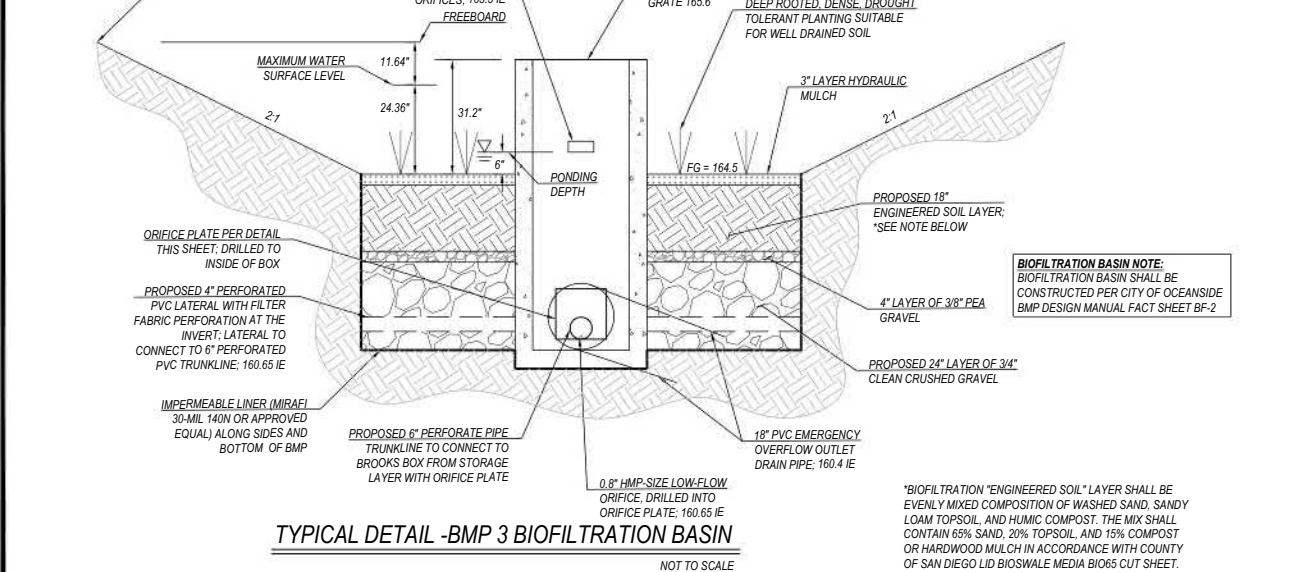

TYPICAL DETAIL - BMP 3 BIOFILTRATION BASIN
NOT TO SCALE

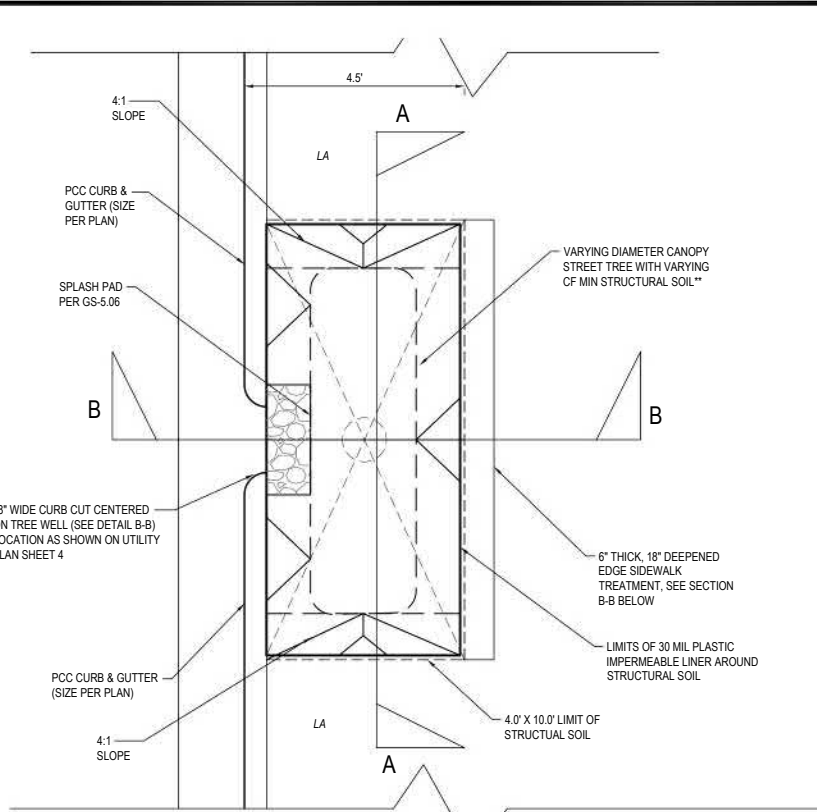

PLAN VIEW - CURB CUT @ TREE WELL SDC GS DS GS-5.01
NOT TO SCALE

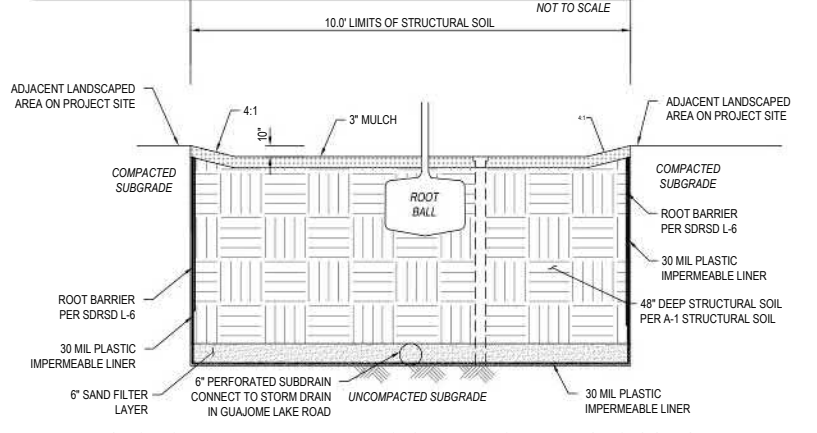

SECTION A-A TREE WELL W/O GRATE MODIFIED SDC GS DS SD-1.04A + GS-1.04B
NOT TO SCALE

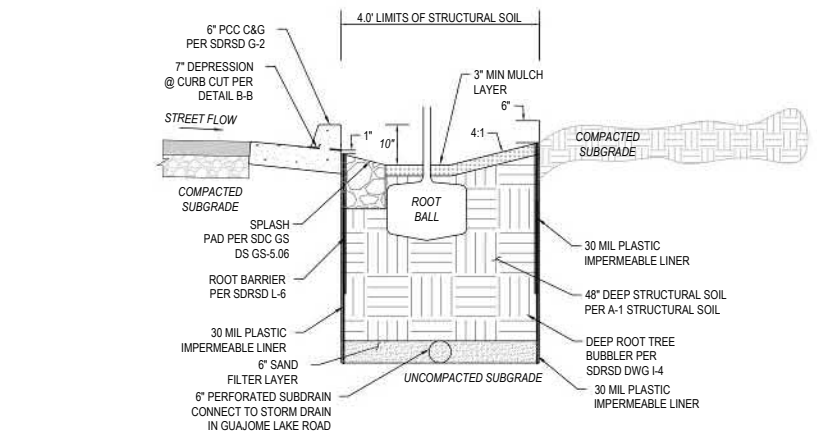

SECTION B-B TREE WELL W/O GRATE MODIFIED SDC GS DS SD-1.04A + GS-1.04B
NOT TO SCALE

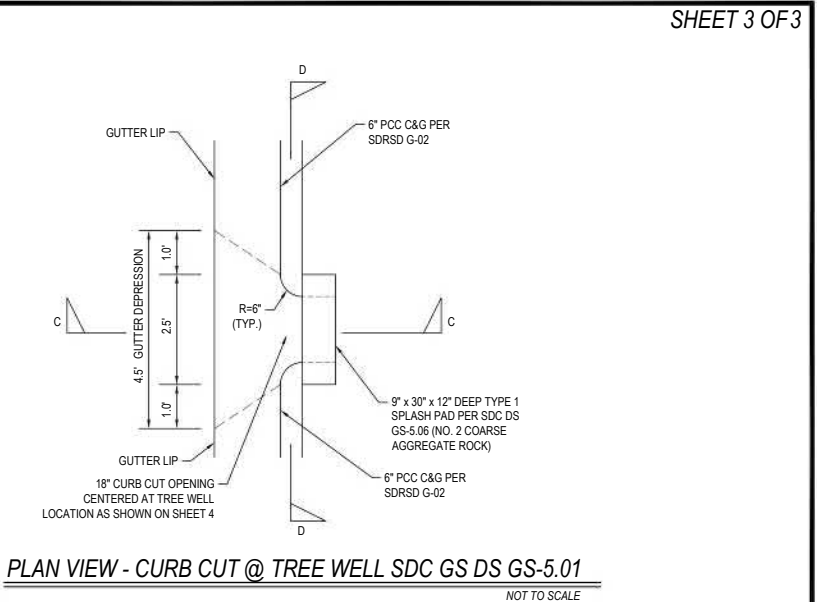

PLAN VIEW - CURB CUT @ TREE WELL SDC GS DS GS-5.01
NOT TO SCALE

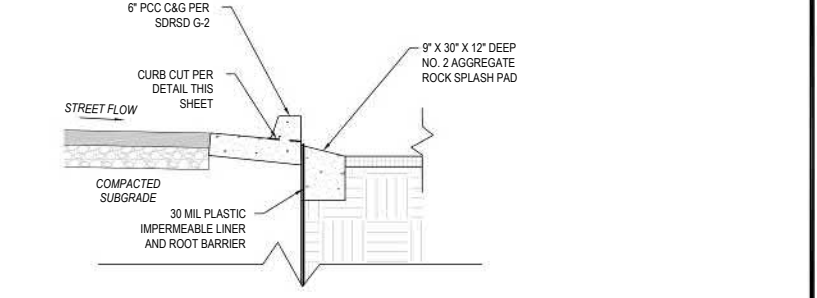

SECTION C-C CURB CUT @ TREE WELL SDC GS DS GS 5.01
NOT TO SCALE

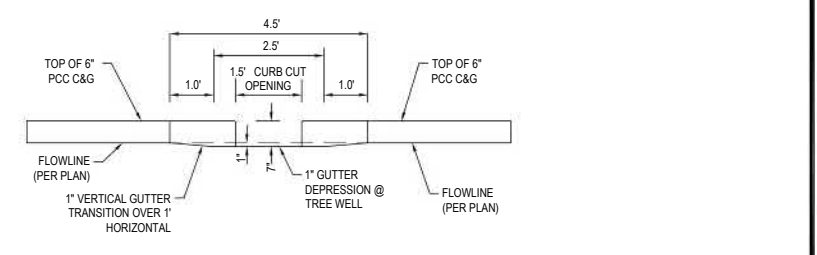

SECTION D-D CURB CUT @ TREE WELL SDC GS DS GS 5.01
NOT TO SCALE

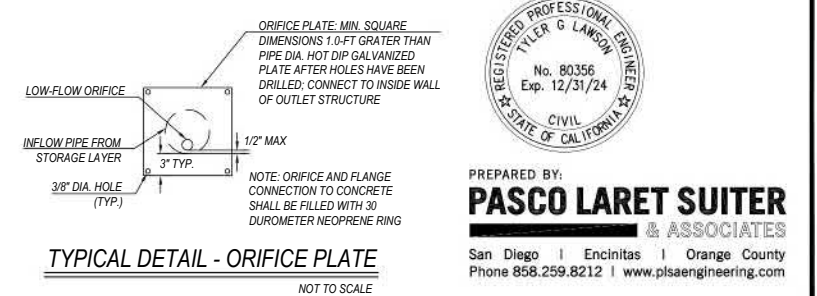

TYPICAL DETAIL - ORIFICE PLATE
NOT TO SCALE



PREPARED BY:
PASCO LARET SUITER & ASSOCIATES
San Diego | Encinitas | Orange County
Phone 858.259.8212 | www.plsengineering.com

Appendix D: Approved Infiltration Rate Assessment Methods

Infiltration Restrictions		Form 4	
Retention is required at the project site to the maximum extent practicable. Complete this form to summarize applicable infiltration restrictions. Supporting documentation must be provided in the Attachments.			
Restriction Element		Applicable?	
Mandatory Considerations	BMP is within 100 feet of contaminated soils	<input type="checkbox"/> Yes	<input checked="" type="checkbox"/> No
	BMP is within 100 feet of industrial activities lacking source control	<input type="checkbox"/> Yes	<input checked="" type="checkbox"/> No
	BMP is within 100 feet of well/groundwater basin	<input type="checkbox"/> Yes	<input checked="" type="checkbox"/> No
	BMP is within 50 feet of septic tanks/leach fields	<input type="checkbox"/> Yes	<input checked="" type="checkbox"/> No
	BMP is within 10 feet of structures/tanks/walls	<input type="checkbox"/> Yes	<input checked="" type="checkbox"/> No
	BMP is within 10 feet of sewer utilities	<input type="checkbox"/> Yes	<input checked="" type="checkbox"/> No
	BMP is within 10 feet of groundwater table	<input type="checkbox"/> Yes	<input checked="" type="checkbox"/> No
	BMP is within hydric soils	<input type="checkbox"/> Yes	<input checked="" type="checkbox"/> No
	BMP is within highly liquefiable soils and has connectivity to structures	<input type="checkbox"/> Yes	<input checked="" type="checkbox"/> No
	BMP is within 1.5 times the height of adjacent steep slopes ($\geq 25\%$)	<input checked="" type="checkbox"/> Yes	<input type="checkbox"/> No
	City staff has assigned “Restricted” Infiltration Category	<input type="checkbox"/> Yes	<input checked="" type="checkbox"/> No
Optional Considerations	BMP is within predominantly Type D soil	<input type="checkbox"/> Yes	<input type="checkbox"/> No
	BMP is within 10 feet of property line	<input type="checkbox"/> Yes	<input type="checkbox"/> No
	BMP is within fill depths of ≥ 5 feet (existing or proposed)	<input checked="" type="checkbox"/> Yes	<input type="checkbox"/> No
	BMP is within 10 feet of underground utilities	<input type="checkbox"/> Yes	<input type="checkbox"/> No
	BMP is within 250 feet of ephemeral stream	<input type="checkbox"/> Yes	<input type="checkbox"/> No
	Other (provide detailed geotechnical support in Attachment 6)	<input type="checkbox"/> Yes	<input type="checkbox"/> No
Result	Unrestricted – No restriction elements are applicable	<input type="checkbox"/>	
	Restricted – One or more restriction elements are applicable	<input checked="" type="checkbox"/>	

Automated Worksheet B.1: Calculation of Design Capture Volume (V2.0)

Category	#	Description	<i>i</i>	<i>i</i> ^x	<i>x</i>	Units
Standard Drainage Basin Inputs	1	Drainage Basin ID or Name	1	2	3	unitless
	2	85th Percentile 24-hr Storm Depth	0.67	0.67	0.67	inches
	3	Impervious Surfaces <u>Not</u> Directed to Dispersion Area (C=0.90)	124,716	86,009	22,690	sq-ft
	4	Semi-Pervious Surfaces <u>Not</u> Serving as Dispersion Area (C=0.30)	79,953	38,007	23,813	sq-ft
	5	Engineered Pervious Surfaces <u>Not</u> Serving as Dispersion Area (C=0.10)				sq-ft
	6	Natural Type A Soil <u>Not</u> Serving as Dispersion Area (C=0.10)				sq-ft
	7	Natural Type B Soil <u>Not</u> Serving as Dispersion Area (C=0.14)				sq-ft
	8	Natural Type C Soil <u>Not</u> Serving as Dispersion Area (C=0.23)				sq-ft
	9	Natural Type D Soil <u>Not</u> Serving as Dispersion Area (C=0.30)				sq-ft
Dispersion Area, Tree Well & Rain Barrel Inputs (Optional)	10	Does Tributary Incorporate Dispersion, Tree Wells, and/or Rain Barrels?	No	No	No	yes/no
	11	Impervious Surfaces Directed to Dispersion Area per SD-B (Ci=0.90)				sq-ft
	12	Semi-Pervious Surfaces Serving as Dispersion Area per SD-B (Ci=0.30)				sq-ft
	13	Engineered Pervious Surfaces Serving as Dispersion Area per SD-B (Ci=0.10)				sq-ft
	14	Natural Type A Soil Serving as Dispersion Area per SD-B (Ci=0.10)				sq-ft
	15	Natural Type B Soil Serving as Dispersion Area per SD-B (Ci=0.14)				sq-ft
	16	Natural Type C Soil Serving as Dispersion Area per SD-B (Ci=0.23)				sq-ft
	17	Natural Type D Soil Serving as Dispersion Area per SD-B (Ci=0.30)				sq-ft
	18	Number of Tree Wells Proposed per SD-A				#
	19	Average Mature Tree Canopy Diameter				ft
	20	Number of Rain Barrels Proposed per SD-E				#
Initial Runoff Factor Calculation	21	Average Rain Barrel Size				gal
	22	Total Tributary Area	204,669	124,016	46,503	sq-ft
	23	Initial Runoff Factor for Standard Drainage Areas	0.67	0.72	0.59	unitless
	24	Initial Runoff Factor for Dispersed & Dispersion Areas	0.00	0.00	0.00	unitless
	25	Initial Weighted Runoff Factor	0.67	0.72	0.59	unitless
	26	Initial Design Capture Volume	7,656	4,985	1,532	cubic-feet
Dispersion Area Adjustments	27	Total Impervious Area Dispersed to Pervious Surface	0	0	0	sq-ft
	28	Total Pervious Dispersion Area	0	0	0	sq-ft
	29	Ratio of Dispersed Impervious Area to Pervious Dispersion Area	n/a	n/a	n/a	ratio
	30	Adjustment Factor for Dispersed & Dispersion Areas	1.00	1.00	1.00	ratio
	31	Runoff Factor After Dispersion Techniques	0.67	0.72	0.59	unitless
	32	Design Capture Volume After Dispersion Techniques	7,656	4,985	1,532	cubic-feet
Tree & Barrel Adjustments	33	Total Tree Well Volume Reduction	0	0	0	cubic-feet
	34	Total Rain Barrel Volume Reduction	0	0	0	cubic-feet
Results	35	Final Adjusted Runoff Factor	0.67	0.72	0.59	unitless
	36	Final Effective Tributary Area	137,128	89,292	27,437	sq-ft
	37	Initial Design Capture Volume Retained by Site Design Elements	0	0	0	cubic-feet
	38	Final Design Capture Volume Tributary to BMP	7,656	4,985	1,532	cubic-feet

No Warning Messages

Automated Worksheet B.2: Retention Requirements (V2.0)

Category	#	Description	<i>i</i>	<i>i</i> ∞	∞	Units
Basic Analysis	1	Drainage Basin ID or Name	1	2	3	unitless
	2	85th Percentile Rainfall Depth	0.67	0.67	0.67	inches
	3	Predominant NRCS Soil Type Within BMP Location	D	D	D	unitless
	4	Is proposed BMP location Restricted or Unrestricted for Infiltration Activities?	Restricted	Restricted	Restricted	unitless
	5	Nature of Restriction	Soil Type	Soil Type	Soil Type	unitless
	6	Do Minimum Retention Requirements Apply to this Project?	Yes	Yes	Yes	yes/no
	7	Are Habitable Structures Greater than 9 Stories Proposed?	No	No	No	yes/no
Advanced Analysis	8	Has Geotechnical Engineer Performed an Infiltration Analysis?	No	No	No	yes/no
	9	Design Infiltration Rate Recommended by Geotechnical Engineer	0.195			in/hr
Result	10	Design Infiltration Rate Used To Determine Retention Requirements	0.000	0.000	0.000	in/hr
	11	Percent of Average Annual Runoff that Must be Retained within DMA	1.5%	1.5%	1.5%	percentage
	12	Fraction of DCV Requiring Retention	0.01	0.01	0.01	ratio
	13	Required Retention Volume	77	50	15	cubic-feet
No Warning Messages						

Automated Worksheet B.3: BMP Performance (V2.0)

Category	#	Description	<i>i</i>	<i>i</i> x	<i>x</i>	Units
BMP Inputs	1	Drainage Basin ID or Name	1	2	3	sq-ft
	2	Design Infiltration Rate Recommended	0.000	0.000	0.000	in/hr
	3	Design Capture Volume Tributary to BMP	7,656	4,985	1,532	cubic-feet
	4	Is BMP Vegetated or Unvegetated?	Vegetated	Vegetated	Vegetated	unitless
	5	Is BMP Impermeably Lined or Unlined?	Lined	Lined	Lined	unitless
	6	Does BMP Have an Underdrain?	Underdrain	Underdrain	Underdrain	unitless
	7	Does BMP Utilize Standard or Specialized Media?	Specialized	Specialized	Standard	unitless
	8	Provided Surface Area	8,045	4,500	1,037	sq-ft
	9	Provided Surface Ponding Depth	6	12	6	inches
	10	Provided Soil Media Thickness	21	21	21	inches
	11	Provided Gravel Thickness (Total Thickness)	40	40	28	inches
	12	Underdrain Offset	3	3	3	inches
	13	Diameter of Underdrain or Hydromod Orifice (Select Smallest)	2.20	2.00	0.80	inches
	14	Specialized Soil Media Filtration Rate	5.00	5.00		in/hr
	15	Specialized Soil Media Pore Space for Retention	0.40	0.40		unitless
	16	Specialized Soil Media Pore Space for Biofiltration	0.40	0.40		unitless
	17	Specialized Gravel Media Pore Space	0.95	0.95		unitless
Retention Calculations	18	Volume Infiltrated Over 6 Hour Storm	0	0	0	cubic-feet
	19	Ponding Pore Space Available for Retention	0.00	0.00	0.00	unitless
	20	Soil Media Pore Space Available for Retention	0.40	0.40	0.05	unitless
	21	Gravel Pore Space Available for Retention (Above Underdrain)	0.00	0.00	0.00	unitless
	22	Gravel Pore Space Available for Retention (Below Underdrain)	0.95	0.95	0.40	unitless
	23	Effective Retention Depth	11.25	11.25	2.25	inches
	24	Fraction of DCV Retained (Independent of Drawdown Time)	0.99	0.85	0.13	ratio
	25	Calculated Retention Storage Drawdown Time	120	120	120	hours
	26	Efficacy of Retention Processes	0.75	0.68	0.15	ratio
	27	Volume Retained by BMP (Considering Drawdown Time)	5,710	3,378	231	cubic-feet
	28	Design Capture Volume Remaining for Biofiltration	1,946	1,607	1,301	cubic-feet
Biofiltration Calculations	29	Max Hydromod Flow Rate through Underdrain	0.2910	0.2519	0.0349	cfs
	30	Max Soil Filtration Rate Allowed by Underdrain Orifice	1.56	2.42	1.45	in/hr
	31	Soil Media Filtration Rate per Specifications	5.00	5.00	5.00	in/hr
	32	Soil Media Filtration Rate to be used for Sizing	1.56	2.42	1.45	in/hr
	33	Depth Biofiltered Over 6 Hour Storm	9.38	14.51	8.71	inches
	34	Ponding Pore Space Available for Biofiltration	1.00	1.00	1.00	unitless
	35	Soil Media Pore Space Available for Biofiltration	0.40	0.40	0.20	unitless
	36	Gravel Pore Space Available for Biofiltration (Above Underdrain)	0.95	0.95	0.40	unitless
	37	Effective Depth of Biofiltration Storage	49.55	55.55	20.20	inches
	38	Drawdown Time for Surface Ponding	4	5	4	hours
	39	Drawdown Time for Effective Biofiltration Depth	32	23	14	hours
	40	Total Depth Biofiltered	58.93	70.06	28.91	inches
	41	Option 1 - Biofilter 1.50 DCV: Target Volume	2,919	2,410	1,951	cubic-feet
	42	Option 1 - Provided Biofiltration Volume	2,919	2,410	1,951	cubic-feet
	43	Option 2 - Store 0.75 DCV: Target Volume	1,460	1,205	976	cubic-feet
	44	Option 2 - Provided Storage Volume	1,460	1,205	976	cubic-feet
	45	Portion of Biofiltration Performance Standard Satisfied	1.00	1.00	1.00	ratio
Result	46	Do Site Design Elements and BMPs Satisfy Annual Retention Requirements?	Yes	Yes	Yes	yes/no
	47	Overall Portion of Performance Standard Satisfied (BMP Efficacy Factor)	1.00	1.00	1.00	ratio
	48	Deficit of Effectively Treated Stormwater	0	0	0	cubic-feet

Attention!

-Use of specialized or proprietary media requires submittal of supplemental information outlined in Appendix F of the BMPDM.

-Minimum annual retention criteria are not satisfied for each individual drainage area. Implement additional site design elements, increase structural BMP retention capacity, or
 -This BMP does not fully satisfy the performance standards for pollutant control for the drainage area.

Design Capture Volume (DMA 1)		Worksheet B-2.1		
1	85 th percentile 24-hr storm depth from Figure B.1-1	d=	0.67	inches
2	Area tributary to BMP (s)	A=	4.70	acres
3	Area weighted runoff factor (estimate using Appendix B.1.1 and B.2.1)	C=	0.67	unitless
4	Street trees volume reduction	TCV=	0	cubic-feet
5	Rain barrels volume reduction	RCV=	0	cubic-feet
6	Calculate DCV = (3630 x C x d x A) – TCV - RCV	DCV=	7,385	cubic-feet



Design Capture Volume (DMA 2)		Worksheet B-2.1		
1	85 th percentile 24-hr storm depth from Figure B.1-1	d=	0.67	inches
2	Area tributary to BMP (s)	A=	2.85	acres
3	Area weighted runoff factor (estimate using Appendix B.1.1 and B.2.1)	C=	0.69	unitless
4	Street trees volume reduction	TCV=	0	cubic-feet
5	Rain barrels volume reduction	RCV=	0	cubic-feet
6	Calculate DCV = (3630 x C x d x A) – TCV - RCV	DCV=	4,803	cubic-feet



Design Capture Volume (DMA 3)		Worksheet B-2.1		
1	85 th percentile 24-hr storm depth from Figure B.1-1	d=	0.67	inches
2	Area tributary to BMP (s)	A=	1.07	acres
3	Area weighted runoff factor (estimate using Appendix B.1.1 and B.2.1)	C=	0.67	unitless
4	Street trees volume reduction	TCV=	0	cubic-feet
5	Rain barrels volume reduction	RCV=	0	cubic-feet
6	Calculate DCV = (3630 x C x d x A) – TCV - RCV	DCV=	1,499	cubic-feet



Harvest and Use Feasibility Checklist	Form I-7
--	-----------------

1. Is there a demand for harvested water (check all that apply) at the project site that is reliably present during the wet season?

Toilet and urinal flushing
 Landscape irrigation
 Other: _____

2. If there is a demand; estimate the anticipated average wet season demand over a period of 36 hours. Guidance for planning level demand calculations for toilet/urinal flushing and landscape irrigation is provided in Section B.3.2.

Toilet and Urinal Demand -> 9.3 Gal / resident Landscape Demand -> 1,470 Gal / irr. Acre mod use
 9.3 gal / day x (0.13368 cu ft / gal) x (1.5 days) = 1.86 cu ft / person over 36 hours
 83 units x 4 people / unit x (1.86 cu ft / person) = 617.52 cu ft / 36 hours (toilet / urinal flushing)
 3.86 AC irrigated x 1,470 gal / ac – 36 hr x 0.13368 cu ft / gal = 758.53 cu ft / 36 hrs (landscaping)
617.5 cu ft + 758.5 cu ft = 1,376 cu ft total over a 36 hour period

3. Calculate the DCV using worksheet B-2.1.

DCV = 13,687 (cubic feet)

3a. Is the 36 hour demand greater than or equal to the DCV? <input type="checkbox"/> Yes / <input checked="" type="checkbox"/> No ⇒ <div style="text-align: center;">↓</div>	3b. Is the 36 hour demand greater than 0.25DCV but less than the full DCV? <input type="checkbox"/> Yes / <input checked="" type="checkbox"/> No ⇒ <div style="text-align: center;">↓</div>	3c. Is the 36 hour demand less than 0.25DCV? <input checked="" type="checkbox"/> Yes <div style="text-align: center;">↓</div>
--	---	---

Harvest and use appears to be feasible. Conduct more detailed evaluation and sizing calculations to confirm that DCV can be used at an adequate rate to meet drawdown criteria.	Harvest and use may be feasible. Conduct more detailed evaluation and sizing calculations to determine feasibility. Harvest and use may only be able to be used for a portion of the site, or (optionally) the storage may need to be upsized to meet long term capture targets while draining in longer than 36 hours.	Harvest and use is considered to be infeasible.
---	---	---

Is harvest and use feasible based on further evaluation?

Yes, refer to Appendix E to select and size harvest and use BMPs.
 No, select alternate BMPs.



E.12 BF-1 Biofiltration



Location: 43rd Street and Logan Avenue, San Diego, California

Description

Biofiltration (Bioretention with underdrain) facilities are vegetated surface water systems that filter water through vegetation, and soil or engineered media prior to discharge via underdrain or overflow to the downstream conveyance system. Bioretention with underdrain facilities are commonly incorporated into the site within parking lot landscaping, along roadsides, and in open spaces. Because these types of facilities have limited or no infiltration, they are typically designed to provide enough hydraulic head to move flows through the underdrain connection to the storm drain system. Treatment is achieved through filtration, sedimentation, sorption, biochemical processes and plant uptake.

Typical bioretention with underdrain components include:

- Inflow distribution mechanisms (e.g, perimeter flow spreader or filter strips)
- Energy dissipation mechanism for concentrated inflows (e.g., splash blocks or riprap)
- Shallow surface ponding for captured flows
- Side slope and basin bottom vegetation selected based on expected climate and ponding depth
- Non-floating mulch layer (Optional)
- Media layer (planting mix or engineered media) capable of supporting vegetation growth
- Filter course layer consisting of aggregate to prevent the migration of fines into uncompacted native soils or the aggregate storage layer
- Aggregate storage layer with underdrain(s)
- Impermeable liner or uncompacted native soils at the bottom of the facility
- Overflow structure

MS4 Permit Category

Biofiltration

Manual Category

Biofiltration

Applicable Performance Standard

Pollutant Control

Flow Control

Primary Benefits

Treatment

Volume Reduction (Incidental)

Peak Flow Attenuation (Optional)

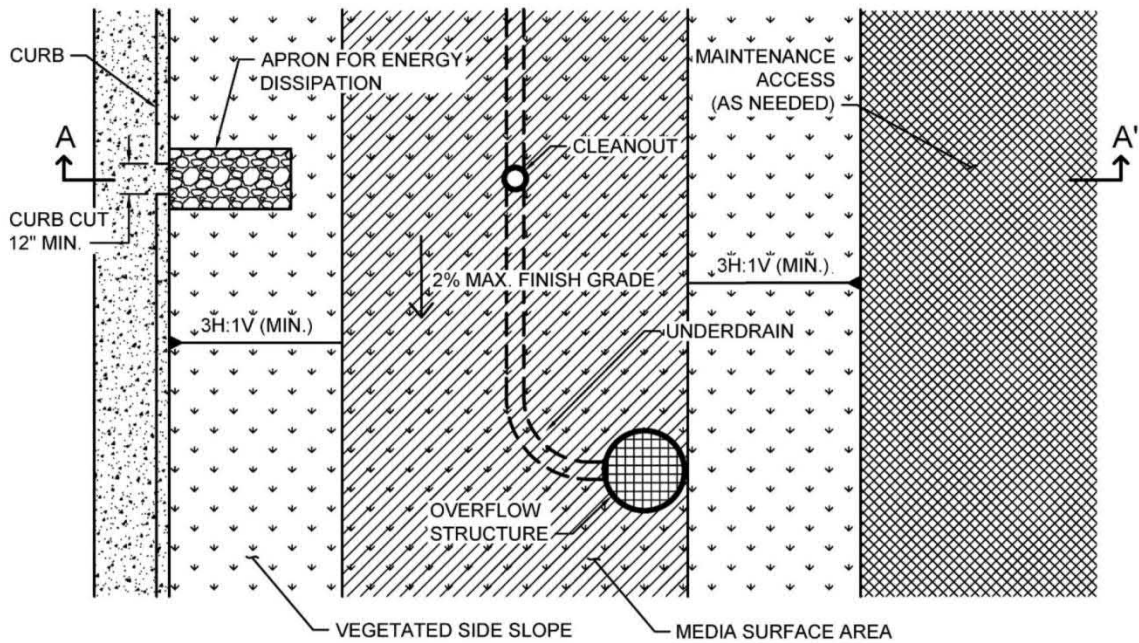

PLAN
NOT TO SCALE

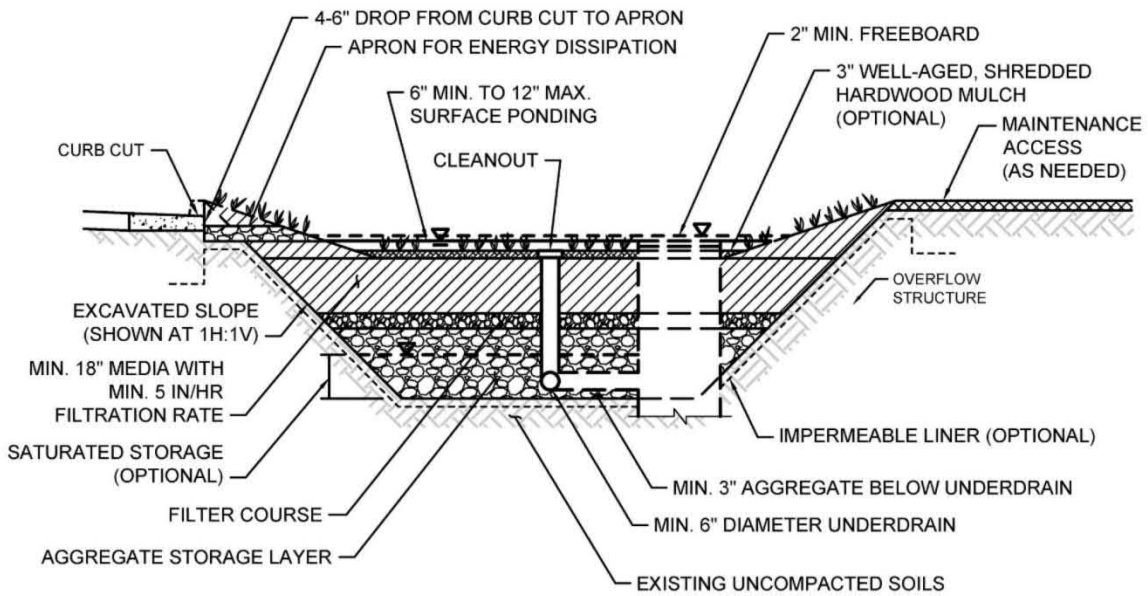

SECTION A-A'
NOT TO SCALE

Typical plan and Section view of a Biofiltration BMP

Design Adaptations for Project Goals

Biofiltration Treatment BMP for storm water pollutant control. The system is lined or un-lined to provide incidental infiltration, and an underdrain is provided at the bottom to carry away filtered runoff. This configuration is considered to provide biofiltration treatment via flow through the media layer. Storage provided above the underdrain within surface ponding, media, and aggregate storage is considered included in the biofiltration treatment volume. Saturated storage within the aggregate storage layer can be added to this design by raising the underdrain above the bottom of the aggregate storage layer or via an internal weir structure designed to maintain a specific water level elevation.

Integrated storm water flow control and pollutant control configuration. The system can be designed to provide flow rate and duration control by primarily providing increased surface ponding and/or having a deeper aggregate storage layer above the underdrain. This will allow for significant detention storage, which can be controlled via inclusion of an outlet structure at the downstream end of the underdrain.

Design Criteria and Considerations

Bioretention with underdrain must meet the following design criteria. Deviations from the below criteria may be approved at the discretion of the City Engineer if it is determined to be appropriate:

<i>Siting and Design</i>	<i>Intent/Rationale</i>
<input checked="" type="checkbox"/> Placement observes geotechnical recommendations regarding potential hazards (e.g., slope stability, landslides, liquefaction zones) and setbacks (e.g., slopes, foundations, utilities).	Must not negatively impact existing site geotechnical concerns.
<input checked="" type="checkbox"/> An impermeable liner or other hydraulic restriction layer is included if site constraints indicate that infiltration or lateral flows should not be allowed.	Lining prevents storm water from impacting groundwater and/or sensitive environmental or geotechnical features. Incidental infiltration, when allowable, can aid in pollutant removal and groundwater recharge.
<input checked="" type="checkbox"/> Contributing tributary area shall be ≤ 5 acres (≤ 1 acre preferred).	Bigger BMPs require additional design features for proper performance. Contributing tributary area greater than 5 acres may be allowed at the discretion of the City Engineer if the following conditions are met: 1) incorporate design features (e.g. flow spreaders) to minimizing short circuiting of flows in

<i>Siting and Design</i>	<i>Intent/Rationale</i>
	the BMP and 2) incorporate additional design features requested by the City Engineer for proper performance of the regional BMP.
<input checked="" type="checkbox"/> Finish grade of the facility is $\leq 2\%$.	Flatter surfaces reduce erosion and channelization within the facility.
<i>Surface Ponding</i>	
<input checked="" type="checkbox"/> Surface ponding is limited to a 24-hour drawdown time.	Surface ponding limited to 24 hours for plant health. Surface ponding drawdown time greater than 24-hours but less than 96 hours may be allowed at the discretion of the City Engineer if certified by a landscape architect or agronomist.
<input checked="" type="checkbox"/> Surface ponding depth is ≥ 6 and ≤ 12 inches.	Surface ponding capacity lowers subsurface storage requirements. Deep surface ponding raises safety concerns. Surface ponding depth greater than 12 inches (for additional pollutant control or surface outlet structures or flow-control orifices) may be allowed at the discretion of the City Engineer if the following conditions are met: 1) surface ponding depth drawdown time is less than 24 hours; and 2) safety issues and fencing requirements are considered (typically ponding greater than 18" will require a fence and/or flatter side slopes) and 3) potential for elevated clogging risk is considered.
<input type="checkbox"/> A minimum of 12 inches of freeboard is provided.	Freeboard provides room for head over overflow structures and minimizes risk of uncontrolled surface discharge.
<input type="checkbox"/> Side slopes are stabilized with vegetation and are = 3H:1V or shallower.	Gentler side slopes are safer, less prone to erosion, able to establish vegetation more quickly and easier to maintain.
<i>Vegetation</i>	

<i>Siting and Design</i>	<i>Intent/Rationale</i>
<input checked="" type="checkbox"/> Plantings are suitable for the climate and expected ponding depth. A plant list to aid in selection can be found in Appendix E.20.	Plants suited to the climate and ponding depth are more likely to survive.
<input checked="" type="checkbox"/> An irrigation system with a connection to water supply should be provided as needed.	Seasonal irrigation might be needed to keep plants healthy.
<i>Mulch</i>	
<input checked="" type="checkbox"/> A minimum of 3 inches of well-aged, shredded hardwood mulch that has been stockpiled or stored for at least 12 months is provided.	Mulch will suppress weeds and maintain moisture for plant growth. Aging mulch kills pathogens and weed seeds and allows the beneficial microbes to multiply.
<i>Media Layer</i>	
<input checked="" type="checkbox"/> Media maintains a minimum filtration rate of 5 in/hr over lifetime of facility. An initial filtration rate of 8 to 12 in/hr is recommended to allow for clogging over time; the initial filtration rate should not exceed 12 inches per hour.	A filtration rate of at least 5 inches per hour allows soil to drain between events. The initial rate should be higher than long term target rate to account for clogging over time. However an excessively high initial rate can have a negative impact on treatment performance, therefore an upper limit is needed.
<input checked="" type="checkbox"/> Media is a minimum 18 inches deep, meeting either of these two media specifications: City of San Diego Storm Water Standards Appendix F.3 (May 2021, unless superseded by more recent edition) or County of San Diego BMP Design Manual: Appendix F.2 Biofiltration Soil Media Composition, Testing, (September 2020, unless superseded by more recent edition). Alternatively, for proprietary designs and custom media mixes not meeting the media specifications contained in the 2021 City of San Diego Storm Water Standards or County LID Manual, the media meets the pollutant treatment performance criteria in Section F.1.	A deep media layer provides additional filtration and supports plants with deeper roots. Standard specifications shall be followed. For non-standard or proprietary designs, compliance with F.1 ensures that adequate treatment performance will be provided.

<i>Siting and Design</i>	<i>Intent/Rationale</i>
<p><input checked="" type="checkbox"/> Media surface area is 3% of contributing area times adjusted runoff factor or greater. Unless demonstrated that the BMP surface area can be smaller than 3%.</p>	<p>Greater surface area to tributary area ratios: a) maximizes volume retention as required by the MS4 Permit and b) decrease loading rates per square foot and therefore increase longevity.</p> <p>Adjusted runoff factor is to account for site design BMPs implemented upstream of the BMP (such as rain barrels, impervious area dispersion, etc.). Refer to Appendix B.2 guidance.</p> <p>Use Worksheet B.5-1 Line 26 to estimate the minimum surface area required per this criteria.</p>
<p><input checked="" type="checkbox"/> Where receiving waters are impaired or have a TMDL for nutrients, the system is designed with nutrient sensitive media design (see fact sheet BF-2).</p>	<p>Potential for pollutant export is partly a function of media composition; media design must minimize potential for export of nutrients, particularly where receiving waters are impaired for nutrients.</p>
<i>Filter Course Layer</i>	
<p><input checked="" type="checkbox"/> A filter course is used to prevent migration of fines through layers of the facility. Filter fabric is not used.</p>	<p>Migration of media can cause clogging of the aggregate storage layer void spaces or subgrade. Filter fabric is more likely to clog.</p>
<p><input checked="" type="checkbox"/> Filter course is washed and free of fines.</p>	<p>Washing aggregate will help eliminate fines that could clog the facility and impede infiltration.</p>
<p><input checked="" type="checkbox"/> Filter course calculations assessing suitability for particle migration prevention have been completed.</p>	<p>Gradation relationship between layers can evaluate factors (e.g., bridging, permeability, and uniformity) to determine if particle sizing is appropriate or if an intermediate layer is needed.</p>
<i>Aggregate Storage Layer</i>	
<p><input checked="" type="checkbox"/> Class 2 Permeable per Caltrans specification 68-1.025 is recommended for the storage layer. Washed, open-graded crushed rock may be used, however a 4-6 inch washed pea gravel</p>	<p>Washing aggregate will help eliminate fines that could clog the aggregate storage layer void spaces or subgrade.</p>

<i>Siting and Design</i>	<i>Intent/Rationale</i>
filter course layer at the top of the crushed rock is required.	
☒ The depth of aggregate provided (12-inch typical) and storage layer configuration is adequate for providing conveyance for underdrain flows to the outlet structure.	Proper storage layer configuration and underdrain placement will minimize facility drawdown time.
<i>Inflow, Underdrain, and Outflow Structures</i>	
☒ Inflow, underdrains and outflow structures are accessible for inspection and maintenance.	Maintenance will prevent clogging and ensure proper operation of the flow control structures.
☒ Inflow velocities are limited to 3 ft/s or less or use energy dissipation methods. (e.g., riprap, level spreader) for concentrated inflows.	High inflow velocities can cause erosion, scour and/or channeling.
☐ Curb cut inlets are at least 12 inches wide, have a 4-6 inch reveal (drop) and an apron and energy dissipation as needed.	Inlets must not restrict flow and apron prevents blockage from vegetation as it grows in. Energy dissipation prevents erosion.
☒ Underdrain outlet elevation should be a minimum of 3 inches above the bottom elevation of the aggregate storage layer.	A minimal separation from subgrade or the liner lessens the risk of fines entering the underdrain and can improve hydraulic performance by allowing perforations to remain unblocked.
☒ Minimum underdrain diameter is 6 inches.	Smaller diameter underdrains are prone to clogging.
☒ Underdrains are made of slotted, PVC pipe conforming to ASTM D 3034 or equivalent or corrugated, HDPE pipe conforming to AASHTO 252M or equivalent.	Slotted underdrains provide greater intake capacity, clog resistant drainage, and reduced entrance velocity into the pipe, thereby reducing the chances of solids migration.
☒ An underdrain cleanout with a minimum 6-inch diameter and lockable cap is placed every 250 to 300 feet as required based on underdrain length.	Properly spaced cleanouts will facilitate underdrain maintenance.
☒ Overflow is safely conveyed to a downstream storm drain system or discharge point Size overflow structure to pass 100-year peak flow	Planning for overflow lessens the risk of property damage due to flooding.

<i>Siting and Design</i>	<i>Intent/Rationale</i>
for on-line infiltration basins and water quality peak flow for off-line basins.	

Conceptual Design and Sizing Approach for Storm Water Pollutant Control Only

To design bioretention with underdrain for storm water pollutant control only (no flow control required), the following steps should be taken:

1. Verify that siting and design criteria have been met, including placement requirements, contributing tributary area, maximum side and finish grade slopes, and the recommended media surface area tributary ratio.
2. Calculate the DCV per Appendix B based on expected site design runoff for tributary areas.
3. Use the sizing worksheet presented in Appendix B.5 to size biofiltration BMPs.

Conceptual Design and Sizing Approach when Storm Water Flow Control is Applicable

Control of flow rates and/or durations will typically require significant surface ponding and/or aggregate storage volumes, and therefore the following steps should be taken prior to determination of storm water pollutant control design. Pre-development and allowable post-project flow rates and durations should be determined as discussed in Chapter 6 of the manual.

1. Verify that siting and design criteria have been met, including placement requirements, contributing tributary area, maximum side and finish grade slopes, and the recommended media surface area tributary ratio.
2. Iteratively determine the facility footprint area, surface ponding and/or aggregate storage layer depth required to provide detention storage to reduce flow rates and durations to allowable limits. Flow rates and durations can be controlled from detention storage by altering outlet structure orifice size(s) and/or water control levels. Multi-level orifices can be used within an outlet structure to control the full range of flows.
3. If bioretention with underdrain cannot fully provide the flow rate and duration control required by this manual, an upstream or downstream structure with significant storage volume such as an underground vault can be used to provide remaining controls.
4. After bioretention with underdrain has been designed to meet flow control requirements, calculations must be completed to verify if storm water pollutant control requirements to treat the DCV have been met.

E.13 BF-2 Nutrient Sensitive Media Design

Some studies of bioretention with underdrains have observed export of nutrients, particularly inorganic nitrogen (nitrate and nitrite) and dissolved phosphorus. This has been observed to be a short-lived phenomenon in some studies or a long term issue in some studies. The composition of the soil media, including the chemistry of individual elements is believed to be an important factor in the potential for nutrient export. Organic amendments, often compost, have been identified as the most likely source of nutrient export. The quality and stability of organic amendments can vary widely.

The biofiltration media specifications contained in the County of San Diego BMP Design Manual: Appendix F.2 Biofiltration Soil Media Composition, Testing, (September 2020, unless superseded by more recent edition) and the City of San Diego Low Impact Development Design Manual (page B-18) (July 2011, unless superseded by more recent edition) were developed with consideration of the potential for nutrient export. These specifications include criteria for individual component characteristics and quality in order to control the overall quality of the blended mixes. As of the publication of this manual, the September 2020 County of San Diego specifications provide more detail regarding mix design and quality control.

The City and County specifications noted above were developed for general purposes to meet permeability and treatment goals. In cases where the BMP discharges to receiving waters with nutrient impairments or nutrient TMDLs, the biofiltration media should be designed with the specific goal of minimizing the potential for export of nutrients from the media. Therefore, in addition to adhering to the City or County media specifications, the following guidelines should be followed:

1. Select plant palette to minimize plant nutrient needs

A landscape architect or agronomist should be consulted to select a plant palette that minimizes nutrient needs. Utilizing plants with low nutrient needs results in less need to enrich the biofiltration soil mix. If nutrient quantity is then tailored to plants with lower nutrient needs, these plants will generally have less competition from weeds, which typically need higher nutrient content. The following practices are recommended to minimize nutrient needs of the plant palette:

- **Utilize native, drought-tolerant plants and grasses where possible.** Native plants generally have a broader tolerance for nutrient content, and can be longer lived in leaner/lower nutrient soils.
- **Start plants from smaller starts or seed.** Younger plants are generally more tolerant of lower nutrient levels and tend to help develop soil structure as they grow. Given the lower cost of smaller plants, the project should be able to accept a plant mortality rate that is somewhat higher than starting from larger plants and providing high organic content.

2. Minimize excess nutrients in media mix

Once the low-nutrient plant palette is established (item 1), the landscape architect and/or agronomist should be consulted to assist in the design of a biofiltration media to balance the interests of plant establishment, water retention capacity (irrigation demand), and the potential for nutrient export. The following guidelines should be followed:

- **The mix should not exceed the nutrient needs of plants.** In conventional landscape design, the nutrient needs of plants are often exceeded intentionally in order to provide a factor of safety for plant survival. This practice must be avoided in biofiltration media as excess nutrients will increase the chance of export. The mix designer should keep in mind that nutrients can be added later (through mulching, tilling of amendments into the surface), but it is not possible to remove nutrients, once added.
- **The actual nutrient content and organic content of the selected organic amendment source should be determined when specifying mix proportions.** Nutrient content (i.e., C:N ratio; plant extractable nutrients) and organic content (i.e., % organic material) are relatively inexpensive to measure via standard agronomic methods and can provide important information about mix design. If mix design relies on approximate assumption about nutrient/organic content and this is not confirmed with testing (or the results of prior representative testing), it is possible that the mix could contain much more nutrient than intended.
- **Nutrients are better retained in soils with higher cation exchange capacity.** Cation exchange capacity can be increased through selection of organic material with naturally high cation exchange capacity, such as peat or coconut coir pith, and/or selection of inorganic material with high cation exchange capacity such as some sands or engineered minerals (e.g., low P-index sands, zeolites, rhyolites, etc). Including higher cation exchange capacity materials would tend to reduce the net export of nutrients. Natural silty materials also provide cation exchange capacity; however potential impacts to permeability need to be considered.
- **Focus on soil structure as well as nutrient content.** Soil structure is loosely defined as the ability of the soil to conduct and store water and nutrients as well as the degree of aeration of the soil. Soil structure can be more important than nutrient content in plant survival and biologic health of the system. If a good soil structure can be created with very low amounts of organic amendment, plants survivability should still be provided. While soil structure generally develops with time, biofiltration media can be designed to promote earlier development of soil structure. Soil structure is enhanced by the use of amendments with high humus content (as found in well-aged organic material). In addition, soil structure can be enhanced through the use of organic material with a distribution of particle sizes (i.e., a more heterogeneous mix).
- **Consider alternatives to compost.** Compost, by nature, is a material that is continually evolving and decaying. It can be challenging to determine whether tests previously done on a given compost stock are still representative. It can also be challenging to determine how the properties of the compost will change once placed in the media bed. More stable materials

such as aged coco coir pith, peat, biochar, shredded bark, and/or other amendments should be considered.

With these considerations, it is anticipated that less than 10 percent organic amendment by volume could be used, while still balancing plant survivability and water retention. If compost is used, designers should strongly consider utilizing less than 10 percent by volume.

3. Design with partial retention and/or internal water storage

An internal water storage zone, as described in Fact Sheet PR-1 is believed to improve retention of nutrients. For lined systems, an internal water storage zone worked by providing a zone that fluctuates between aerobic and anaerobic conditions, resulting in nitrification/denitrification. In soils that will allow infiltration, a partial retention design (PR-1) allows significant volume reduction and can also promote nitrification/denitrification.

Acknowledgment: This fact sheet has been adapted from the Orange County Technical Guidance Document (May 2011). It was originally developed based on input from: Deborah Deets, City of Los Angeles Bureau of Sanitation, Drew Ready, Center for Watershed Health, Rick Fisher, ASLA, City of Los Angeles Bureau of Engineering, Dr. Garn Wallace, Wallace Laboratories, Glen Dake, GDML, and Jason Schmidt, Tree People. The guidance provided herein does not reflect the individual opinions of any individual listed above and should not be cited or otherwise attributed to those listed.

E.2 SD-1 Street Trees



Street Trees (Source: County of San Diego LID Manual – EOA, Inc.)

MS4 Permit Category

Site Design

Manual Category

Site Design

Applicable Performance Standard

Site Design

Primary Benefits

Volume Reduction

Description

Trees planted to intercept rainfall and runoff can be used as storm water management measures that provide additional benefits beyond those typically associated with trees, including energy conservation, air quality improvement, and aesthetic enhancement. Typical storm water management benefits associated with trees include:

- **Interception of rainfall** – tree surfaces (roots, foliage, bark, and branches) intercept, evaporate, store, or convey precipitation to the soil before it reaches surrounding impervious surfaces
- **Reduced erosion** – trees protect denuded area by intercepting or reducing the velocity of rain drops as they fall through the tree canopy
- **Increased infiltration** – soil conditions created by roots and fallen leaves promote infiltration
- **Treatment of storm water** – trees provide treatment through uptake of nutrients and other storm water pollutants (phytoremediation) and support of other biological processes that break down pollutants

Typical street tree system components include:

- Trees of the appropriate species for site conditions and constraints
- Available growing space based on tree species, soil type, water availability, surrounding land uses, and project goals

- Optional suspended pavement design to provide structural support for adjacent pavement without requiring compaction of underlying layers
- Optional root barrier devices as needed; a root barrier is a device installed in the ground, between a tree and the sidewalk, intended to guide roots down and away from the sidewalk in order to prevent sidewalk lifting from tree roots.
- Optional tree grates; to be considered to maximize available space for pedestrian circulation and to protect tree roots from compaction related to pedestrian circulation; tree grates are typically made up of porous material that will allow the runoff to soak through.
- Optional shallow surface depression for ponding of excess runoff
- Optional planter box drain

Design Adaptations for Project Goals

Site design BMP to provide incidental treatment. Street trees primarily functions as site design BMPs for incidental treatment. Benefits from street trees are accounted for by adjustment factors presented in Appendix B.2. This credit can apply to non-street trees as well (that meet the same criteria). Trees as a site design BMP are only credited up to 0.25 times the DCV from the project footprint (with a maximum single tree credit volume of 400 ft³).

Storm water pollutant control BMP to provide treatment. Applicants are allowed to design trees as a pollutant control BMP and obtain credit greater than 0.25 times the DCV from the project footprint (or a credit greater than 400 ft³ from a single tree). For this option to be approved by the City Engineer, applicant is required to do infiltration feasibility screening (Appendix C and D) and provide calculations supporting the amount of credit claimed from implementing trees within the project footprint. The City Engineer has the discretion to request additional analysis before approving credits greater than 0.25 times the DCV from the project footprint (or a credit greater than 400 ft³ from a single tree).

Design Criteria and Considerations

Street Trees must meet the following design criteria and considerations. Deviations from the below criteria may be approved at the discretion of the City Engineer if it is determined to be appropriate:

<i>Siting and Design</i>	<i>Intent/Rationale</i>
<input type="checkbox"/> Tree species is appropriately chosen for the development (private or public). For public rights-of-ways, City planning guidelines and zoning provisions for the permissible species and placement of trees are consulted. A list of trees appropriate for site design that can be used by all county municipalities are provided in	Proper tree placement and species selection minimizes problems such as pavement damage by surface roots and poor growth.

Siting and Design

Intent/Rationale

Appendix E.20

Location of trees planted along public streets follows City requirements and guidelines. Vehicle and pedestrian line of sight are considered in tree selection and placement.

Unless exemption is granted by the City Engineer the following minimum tree separation distance is followed

Improvement	Minimum distance to Street Tree
☒ Traffic Signal, Stop sign	20 feet
Underground Utility lines (except sewer)	5 feet
Sewer Lines	10 feet
Above ground utility structures (Transformers, Hydrants, Utility poles, etc.)	10 feet
Driveways	10 feet
Intersections (intersecting curb lines of two streets)	25 feet

Roadway safety for both vehicular and pedestrian traffic is a key consideration for placement along public streets.

☒ **Underground utilities and overhead wires** are considered in the design and avoided or circumvented. Underground utilities are routed around or through the planter in suspended pavement applications. All underground utilities are protected from water and root penetration.

Tree growth can damage utilities and overhead wires resulting in service interruptions. Protecting utilities routed through the planter prevents damage and service interruptions.

<i>Siting and Design</i>	<i>Intent/Rationale</i>
<p><input type="checkbox"/> Suspended pavement design was developed where appropriate to minimize soil compaction and improve infiltration and filtration capabilities.</p> <p>Suspended pavement was constructed with an approved structural cell.</p>	<p>Suspended pavement designs provide structural support without compaction of the underlying layers, thereby promoting tree growth.</p> <p>Recommended structural cells include poured in place concrete columns, Silva Cells manufactured by Deeproot Green Infrastructures and Stratacell and Stratavault systems manufactured by Citygreen Systems.</p>
<p><input checked="" type="checkbox"/> A minimum soil volume of 2 cubic feet per square foot of canopy projection volume is provided for each tree. Canopy projection area is the ground area beneath the tree, measured at the drip line.</p>	<p>The minimum soil volume ensures that there is adequate storage volume to allow for unrestricted evapotranspiration.</p> <p>A lower amount of soil volume may be allowed at the discretion of the City Engineer if certified by a landscape architect or agronomist. The retention credit from the tree is directly proportional to the soil volume provided for the tree.</p>
<p><input type="checkbox"/> DCV from the tributary area draining to the tree is equal to or greater than the tree credit volume</p>	<p>The minimum tributary area ensures that the tree receives enough runoff to fully utilize the infiltration and evapotranspiration potential provided. In cases where the minimum tributary area is not provided, the tree credit volume must be reduced proportionately to the actual tributary area.</p>
<p>Inlet opening to the tree that is at least 18 inches wide.</p> <p><input checked="" type="checkbox"/> A minimum 2 inch drop in grade from the inlet to the finish grade of the tree.</p> <p>Grated inlets are allowed for pedestrian circulation. Grates need to be ADA compliant and have sufficient slip resistance.</p>	<p>Design requirement to ensure that the runoff from the tributary area is not bypassed.</p> <p>Different inlet openings and drops in grade may be allowed at the discretion of the City Engineer if calculations are shown that the diversion flow rate (Appendix B.1.2) from the tributary area can be conveyed to the tree. In cases where the inlet capacity is limiting the amount of runoff draining to the tree, the</p>

<i>Siting and Design</i>	<i>Intent/Rationale</i>
	tree credit volume must be reduced proportionately.

Conceptual Design and Sizing Approach for Site Design

1. Determine the areas where street trees can be used in the site design to achieve incidental treatment. Street trees reduce runoff volumes from the site. Refer to Appendix B.2. Document the proposed tree locations in the SWQMP.
2. When trees are proposed as a storm water pollutant control BMP, applicant must complete feasibility analysis in Appendix C and D and submit detailed calculations for the DCV treated by trees. Document the proposed tree locations, feasibility analysis and sizing calculations in the SWQMP. The following calculations should be performed and the smallest of the three should be used as the volume treated by trees:
 - a. Delineate the DMA (tributary area) to the tree and calculate the associated DCV.
 - b. Calculate the required diversion flow rate using Appendix B.1.2 and size the inlet required to convey this flow rate to the tree. If the proposed inlet cannot convey the diversion flow rate for the entire tributary area, then the DCV that enters the tree should be proportionally reduced.
 - i. For example, 0.5 acre drains to the tree and the associated DCV is 820 ft³. The required diversion flow rate is 0.10 ft³/s, but only an inlet that can divert 0.05 ft³/s could be installed.
 - ii. Then the effective DCV draining to the tree = 820 ft³ * (0.05/0.10) = 420 ft³
 - c. Estimate the amount of storm water treated by the tree by summing the following:
 - i. Evapotranspiration credit of 0.1 * amount of soil volume installed; and
 - ii. Infiltration credit calculated using sizing procedures in Appendix B.4.

R-TANK[®]
STORMWATER
STORAGE
SYSTEM





STORMWATER MANAGEMENT

IS YOUR STORMWATER SYSTEM TAKING UP TOO MUCH SPACE?

R-Tank can reduce your underground stormwater storage system footprint, avoiding nearby utility conflicts, freeing up space for future expansion and overcoming construction phase challenges.

DOES YOUR PROJECT REQUIRE A UNIQUE SOLUTION DUE TO DEPTH OR TRAFFIC LOADS?

R-Tank provides system height options from 2 inches to over 7 feet tall. It also accommodates HS-20 and HS-25 loading with cover depths as little as 6" and as deep as 16'.



R-Tank solves tough stormwater problems by adapting to the needs of your site—whether you are designing a project with shallow ground water or deep cover conditions.

R-TANK

BENEFITS

HIGH CAPACITY

- 95% void internal area (LD, HD, SD, UD)
- 90% void internal area (XD)

STRENGTH

- Supports traffic loading
- Module options for HS-20 and HS-25 rating with cover depths from 6" to 16'

DESIGN AND CONSTRUCTION VERSATILITY

- Modules can be combined into various shapes to use space efficiently and effectively
- Module heights vary from 2" to 7'

INCREASED INFILTRATION AND EXFILTRATION

- 90% open area on face of modules
- Increases groundwater recharge, reducing post-construction discharge volumes

EASY TO TRANSPORT

- Can be supplied preassembled or unassembled to reduce delivery costs

LIGHTWEIGHT AND QUICK TO INSTALL

- Installed by hand; no cranes required
- Reduces site access delays

RECYCLED CONTENT

- Manufactured with post industrial grade recycled polypropylene



PRODUCTS

R-TANK **LD**

- Light-duty module (30 psi)
- Ideal for applications in green space
- Not rated for vehicular traffic
- 12" minimum cover
- 36" maximum cover
- Four internal plates

R-TANK **HD**

- Heavy-duty module (33.4 psi)
- 20" minimum cover
- 84" maximum cover
- Five internal plates
- Standard module for traffic applications



R-TANK **SD**

- Super-duty module (42.9 psi)
- Higher safety factors for shallow traffic applications and deeper cover
- 18" minimum cover
- 120" maximum cover



R-TANK **UD**

- Ultra-duty module (134.2 psi)
- Traffic loads with 12" of cover
- Available from 14" to 66" tall
- Ideal for high water table sites



R-TANK **XD**

- Extreme-duty module (320 psi)
- Traffic loads with 6" cover
- 16.5' maximum cover
- Available from 2" to 10' tall



DESIGN CONSIDERATIONS

Many factors will influence the design of the R-Tank system. While this list is not intended to be all-inclusive, the following design considerations are worth highlighting:

1. PRE-TREATMENT

Removing pollutants from runoff before they enter an underground detention system is the smart way to design and build a system. Trash Guard Plus® is a great tool for this. Be sure the system you select will remove heavy sediments, gross pollutants (trash) and biodegradable debris.

2. BACKFILL MATERIALS

Backfill materials should be angular stone (<1.5" in diameter) or soil (GW, GP SW or SP per the Unified Soil Classification System). Material must be free from lumps, debris and sharp objects that could cut the geotextile. See the R-Tank narrative specification for additional information.

3. RUNOFF REDUCTION

Most designs incorporate an outlet to drain the system at a controlled rate and/or an overflow to prevent flooding in extreme events. Any infiltration that can be achieved on the site should also be taken advantage of. Consider raising the invert of your outlet or creating a sump to capture and infiltrate the water quality volume whenever possible.

4. WATER TABLE

While installing R-Tank below the water table is manageable, a stable base must be created to support the system. Ground water can be allowed to enter and drain from the system, or a liner can be used to prevent ground water from entering the system if measures are taken to prevent the system from floating.

5. CONSTRUCTION LOADS

Construction loads are often the heaviest loads the system will experience. Care must be taken during backfilling and compaction, and post-installation construction traffic should be routed around the system.

6. LATERAL LOADS

As systems get deeper, the loads acting on the sides of the tank increase. While vertical loads often control the design, lateral loads should also be considered.

7. R-TANK MODULES

Selecting the right module for your application is critical. See page 3 and the specs on the back of this brochure for details. Our team is also here to help!

8. LOAD MODELING

A safety factor of >1.75 is required when designing an R-Tank System using the AASHTO LRFD Bridge Design Specifications. It is also necessary to run your own loading model with site specific requirements.

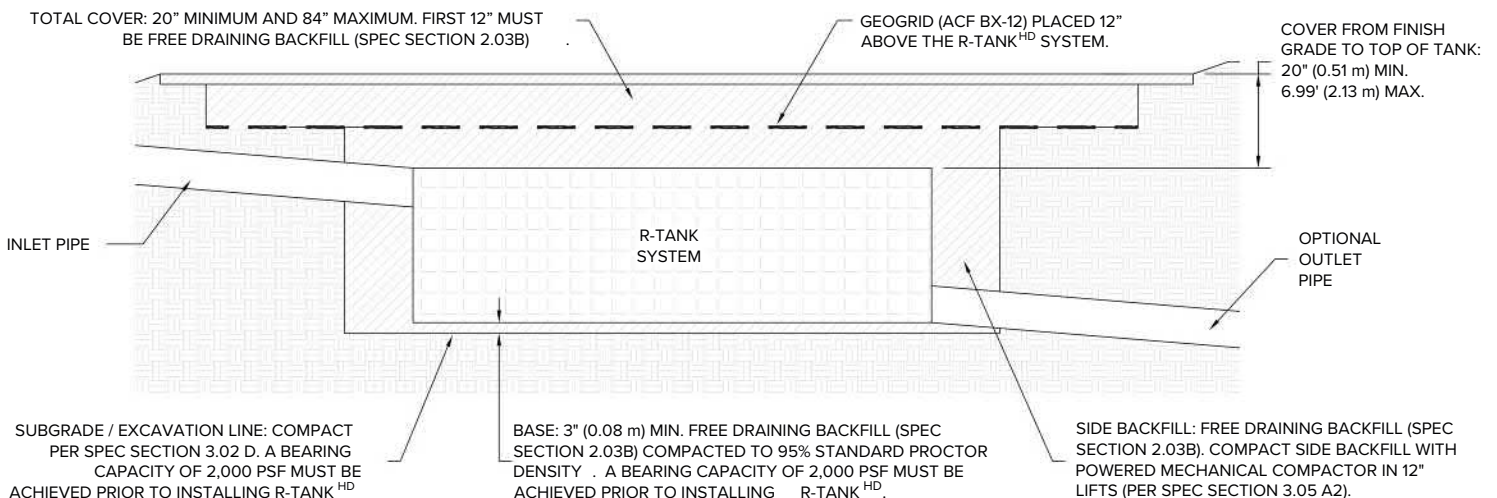

CREATIVE GREEN STORMWATER INFRASTRUCTURE APPLICATIONS



R-TANK UNDER PERMEABLE AND POROUS SURFACES

For projects with shallow depth restrictions and high ground water table elevations, R-Tank can be strategically deployed beneath permeable and porous surfaces. The high void space of the modules allows designers to maximize the volume stored at shallow depths and converts the permeable/porous surface into an “inlet” to the storage below. Ferguson offers a selection of “alternative surfaces” that can be paired with the R-Tank.



R-TANK IN LINEAR GREEN STREETSCAPES

Based on its space efficiency and modular versatility, the R-Tank is a popular option for storage of stormwater in urban linear street applications. Beyond the void efficiency, the system layout can be easily adjusted to work around unexpected utility conflicts and other site features. Green Infrastructure programs in Philadelphia, Pittsburgh, New York City, and Salt Lake City are just a few examples of where R-Tank has been adopted in this application.



UNDER BIORETENTION FOR ENHANCED STORAGE

In many green stormwater practices, R-Tank can offer an “enhanced” storage zone providing 95% void space vs. the typical 40% void space of stone. Throughout the country, engineers have utilized this approach to maximize capacity and reduce the depth of excavation of the storage layer in rain gardens, bioretention and curbside vegetated stormwater practices.



COMBINED WITH INNOVATIVE MEDIA

Ferguson offers a series of innovative stormwater filtration media to provide water quality treatment. The R-Tank can be used in these systems as a space-efficient high-performance underdrain with the option to expand over larger footprints for infiltration or detention. R-Tank can also be used to house media in certain applications and systems.



INNOVATIVE APPLICATIONS (FLOOD MITIGATION, RE-USE, ETC.)

The R-Tank is a popular choice under playgrounds and sports fields. The high void space and the ability to work around light pole bases, equipment footings and foundations allows municipalities to maximize storage when developing or redeveloping these community gems. The system can also be lined and combined with pump equipment for irrigation and other re-use applications.

MAINTENANCE

DESIGNING AN R-TANK SYSTEM WITH LONGEVITY & MAINTENANCE IN MIND IS A THREE-STEP PROCESS:

1. PRE-TREAT

Keep debris out of the system using decentralized filters and screens. Ferguson offers a complete range of options from perforated screen devices to high flow geotextile bag and cartridge based filter drain inserts.

2. ISOLATE

Trap solid pollutants inside the treatment row (see treatment row drawing below) where they can be easily removed using the access modules (available in LD, HD, and UD only). These modules are wrapped in geotextile to retain solids and are fully accessible by conventional jet-vac systems to remove captured pollutants.

3. PROTECT

Ensure a long system life by including maintenance ports to remove any pollutants that evade the pre-treatment system and treatment row. Maintenance ports should be specified within 10' of inlet and outlet connections, and roughly 50' on center.

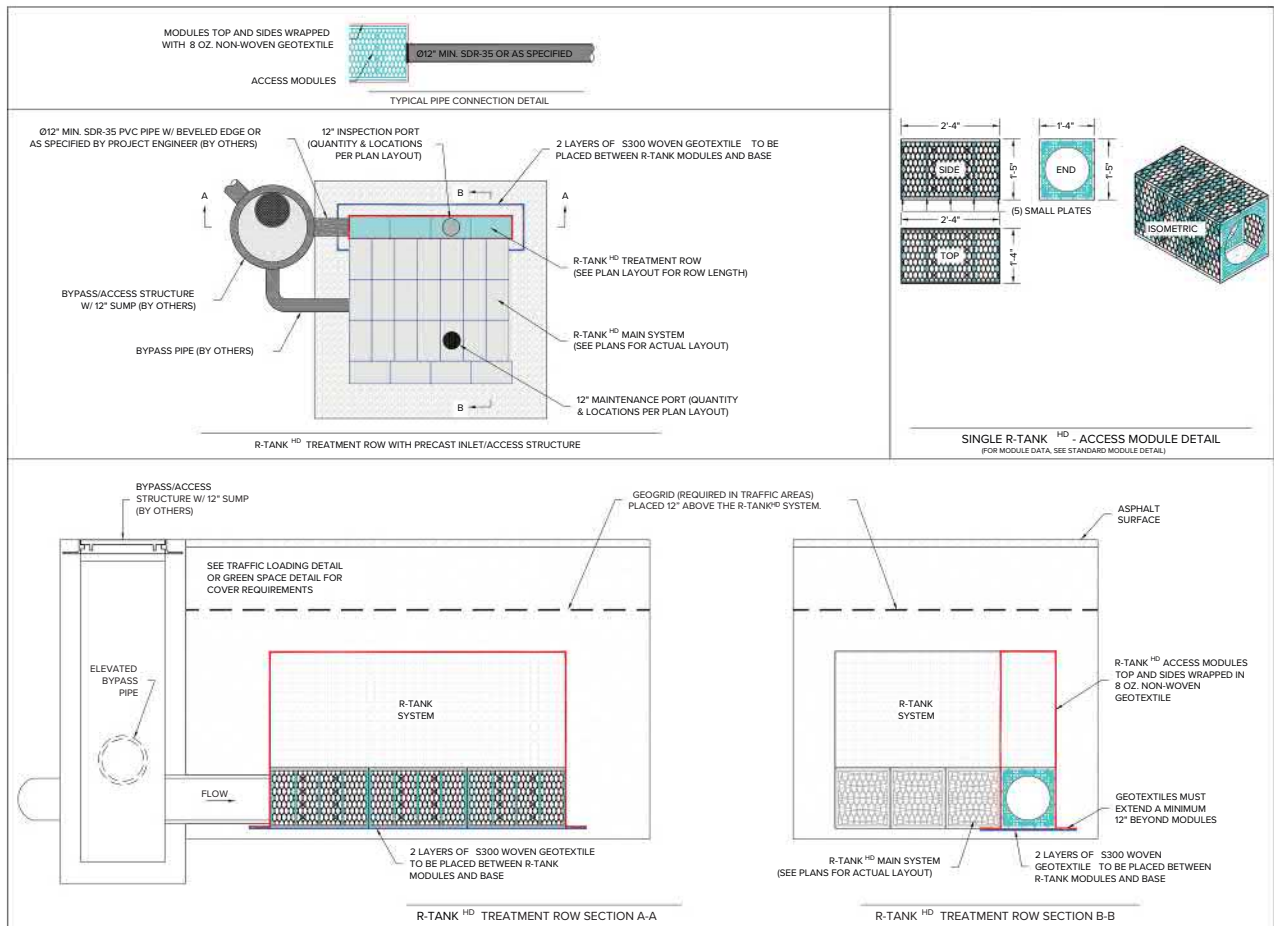

PRE-TREATMENT DEVICES

From simple trash and debris screens to filters for targeted pollutants, Ferguson offers a complete selection of decentralized pre-treatment devices.



TRASHGUARD PLUS



FABCO STORMBASIN



FABCO STORMRING



FABCO STORMSACK



SUPPORT SERVICES AND TANK SELECTION

Our regional engineers and designers are well versed in local regulations, innovative urban green street applications and can help develop site-specific solutions using one or a combination of our products. Our team produces high-quality custom layouts and details to support your permitting and construction efforts. From AutoCAD to HydroCAD, we have a variety of design tools to help you move through the permitting process efficiently.

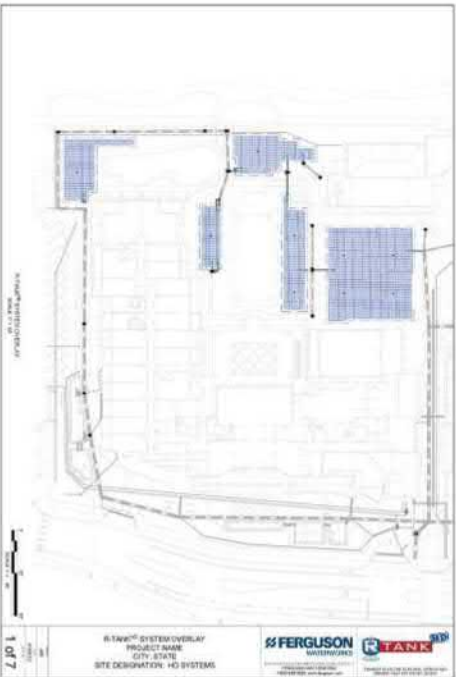

SAMPLE R-TANK SYSTEM OVERLAY



R-TANK SD INSTALLATION

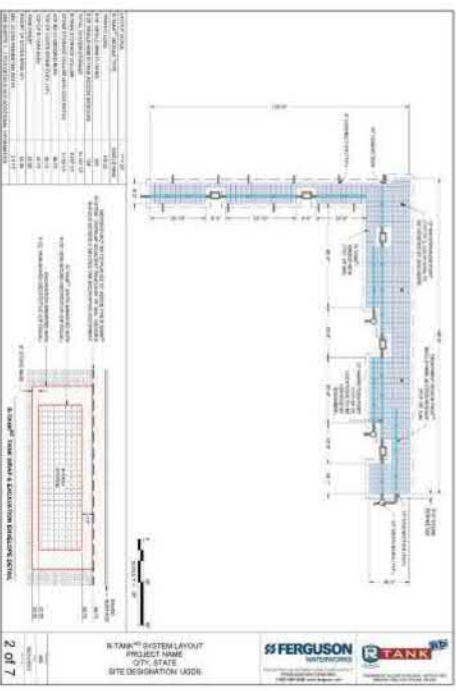

SAMPLE R-TANK SYSTEM LAYOUT



R-TANK WITHIN BUILDING FOOTPRINT

SELECTING THE RIGHT R-Tank MODULE

Cover Depth (Inches)*	LRFD	HRFD	SRD	URD	SRD
Min. 6"	Green Space - No Traffic	Green Space - No Traffic	Green Space - No Traffic	Green Space - No Traffic	HS-20
12"	Green Space - No Traffic	Green Space - No Traffic	Green Space - No Traffic	HS-20**	HS-20
14"	Green Space - No Traffic	Green Space - No Traffic	Green Space - No Traffic	HS-20	HS-20
18"	Green Space - No Traffic	Green Space - No Traffic	HS-20	HS-20	HS-20
20"	Green Space - No Traffic	HS-20	HS-20	HS-20	HS-20
24"	Green Space - No Traffic	HS-20	HS-20	HS-20	HS-20
36"	Green Space - No Traffic	HS-20	HS-20	HS-20	HS-20
48"		HS-20	HS-20	HS-20	HS-20
60"		HS-20	HS-20	HS-20	HS-20
72"		HS-20	HS-20	HS-20	HS-20
84"			HS-20	HS-20	HS-20
120"			HS-20	HS-20	HS-20
160"				HS-20	HS-20
Max. 200"				HS-20	HS-20

HS-20 designation based on AASHTO LRFD Bridge Design Specification for single lane traffic.

*Cover depth is measured from top of module to finished grade or top of pavement.

**The UD module requires STONE backfill (not soil) on sides at this depth.

R-TANK SPECIFICATIONS



DIMENSIONS & CAPACITY

Module (Segments)	Width (in)	Length (in)	Height (in/ft)	Volume (cf)	Capacity (cf)	Weight* (lbs)
Mini	15.75	28.15	9.45"/0.79'	2.42	2.30	10.1/10.9
Single (1)	15.75	28.15	17.32"/1.44'	4.44	4.22	15.7/17.3
Single + Mini (1.5)	15.75	28.15	25.98"/2.17'	6.67	6.33	23.6/25.9
Double (2)	15.75	28.15	33.86"/2.82'	8.69	8.25	29.1/32.3
Double + Mini (2.5)	15.75	28.15	42.52"/3.54'	10.91	10.36	37.0/41.0
Triple (3)	15.75	28.15	50.39"/4.20'	12.93	12.28	42.5/47.4
Triple + Mini (3.5)	15.75	28.15	59.06"/4.92'	15.15	14.39	50.4/56.0
Quad (4)	15.75	28.15	66.93"/5.58'	17.17	16.31	55.9/62.4
Quad + Mini (4.5)	15.75	28.15	75.59"/6.30'	19.39	18.42	63.8/71.0
Pent (5)	15.75	28.15	83.46"/6.96'	21.41	20.34	69.3/77.4

*Weights shown are for LD/HD modules.



DIMENSIONS & CAPACITY

Module (Segments)	Width (in)	Length (in)	Height (in/ft)	Volume (cf)	Capacity (cf)	Weight (lbs)
Single (1)	15.75	28.15	9.45"/0.79'	2.42	2.30	10.95
Double (2)	15.75	28.15	18.12"/1.51'	4.64	4.41	19.58
Triple (3)	15.75	28.15	26.79"/2.23'	6.86	6.52	28.21
Quad (4)	15.75	28.15	35.46"/2.96'	9.08	8.63	36.84
Pent (5)	15.75	28.15	44.13"/3.68'	11.30	10.74	45.47
Hex (6)	15.75	28.15	52.80"/4.40'	13.52	12.84	54.10
Septa (7)	15.75	28.15	61.47"/5.12'	15.74	14.95	62.73
Octo (8)	15.75	28.15	70.14"/5.85'	17.96	17.06	71.36
Nono (9)	15.75	28.15	78.81"/6.57'	20.18	19.17	79.99
Decka (10)	15.75	28.15	87.48"/7.29'	22.40	21.28	88.62



DIMENSIONS & CAPACITY

Module (Segments)	Width (in)	Length (in)	Height (in/ft)	Volume (cf)	Capacity (cf)	Weight (lbs)
Single (1)	23.62	23.62	14.17"/1.18'	4.57	4.35	21.2
Double (2)	23.62	23.62	27.17"/2.26'	8.77	8.33	39.0
Triple (3)	23.62	23.62	40.16"/3.35'	12.97	12.32	56.8
Quad (4)	23.62	23.62	53.15"/4.43'	17.16	16.30	74.6
Pent (5)	23.62	23.62	66.14"/5.5'	21.35	20.29	92.4



DIMENSIONS & CAPACITY

Module (Segments)	Width (in)	Length (in)	Height (in)	Volume (cf)	Capacity (cf)	Weight (lbs)
Single (1)	19.68	23.62	1.97	0.53	0.48	4
Double (2)	19.68	23.62	3.94	1.06	0.95	8
Triple (3)	19.68	23.62	5.91	1.59	1.43	12
Quad (4)	19.68	23.62	7.87	2.12	1.91	16
Pent (5)	19.68	23.62	9.84	2.65	2.38	20

Note: XD modules may be stacked up to 10' tall (60 layers).

SPECIFICATIONS

Item	Description	LD	HD	SD	UD	XD
		Value	Value	Value	Value	Value
Void Area	Volume available for water storage	95%	95%	95%	95%	90%
Surface Area Void	% of exterior available for infiltration	90%	90%	90%	90%	90%
Compressive Strength	ASTM D 2412/ASTM F 2318	30.0 psi	33.4 psi	42.9 psi	134.2 psi	320 psi
Unit Weight	Weight of plastic per cubic foot of tank	3.29 lbs/cf	3.62 lbs/cf	3.96 lbs/cf	4.33 lbs/cf	7.55 lbs/cf
Rib Thickness	Thickness of load-bearing members	0.18"	0.18"	0.18"	-	-
Service Temperature	Safe temperature range for use	-14-167° F	-14-167° F	-14-167° F	-14-167° F	-14-167° F
Recycled Content	Use of recycled polypropylene	100%	100%	100%	100%	100%
Minimum Cover	Cover required for HS-20 loading	Not traffic rated	20"	18"	12"-14"	6"
	Cover required for HS-25 loading	Not traffic rated	24"	18"	15"-17"	6"
Maximum Cover	Maximum allowable cover depth	36"	6.99'	9.99'	5.0'	16.7'

Contact your local sales associate:

Call **866-684-9177** or visit **FERGUSONGSS.COM** to get started.



ATTACHMENT 2
BACKUP FOR PDP HYDROMODIFICATION CONTROL MEASURES

This is the cover sheet for Attachment 2.

Mark this box if this attachment is empty because the project is exempt from PDP hydromodification management requirements.



Indicate which Items are Included:

Attachment Sequence	Contents	Checklist
Attachment 2a	1. Hydromodification Management Exhibit (Required)	<input checked="" type="checkbox"/> Included See Hydromodification Management Exhibit Checklist.
Attachment 2b	Management of Critical Coarse Sediment Yield Areas (WMAA Exhibit is required, additional analyses are optional) See Section 6.2 of the BMP Design Manual.	<input checked="" type="checkbox"/> Exhibit showing project drainage boundaries marked on WMAA Critical Coarse Sediment Yield Area Map (Required) Optional analyses for Critical Coarse Sediment Yield Area Determination <input type="checkbox"/> 6.2.1 Verification of Geomorphic Landscape Units Onsite <input type="checkbox"/> 6.2.2 Downstream Systems Sensitivity to Coarse Sediment <input checked="" type="checkbox"/> 6.2.3 Optional Additional Analysis of Potential Critical Coarse Sediment Yield Areas Onsite
Attachment 2c	Geomorphic Assessment of Receiving Channels (Optional) See Section 6.3.4 of the BMP Design Manual.	<input checked="" type="checkbox"/> Not performed <input type="checkbox"/> Included <input type="checkbox"/> Submitted as separate stand-alone document
Attachment 2d	Flow Control Facility Design and Structural BMP Drawdown Calculations (Required) Overflow Design Summary for each structural BMP See Chapter 6 and Appendix G of the BMP Design Manual	<input checked="" type="checkbox"/> Included <input type="checkbox"/> Submitted as separate stand-alone document
Attachment 2e	Vector Control Plan (Required when structural BMPs will not drain in 96 hours)	<input type="checkbox"/> Included <input checked="" type="checkbox"/> Not required because BMPs will drain in less than 96 hours



Use this checklist to ensure the required information has been included on the Hydromodification Management Exhibit:

The Hydromodification Management Exhibit must identify:

- Underlying hydrologic soil group
- Approximate depth to groundwater
- Existing natural hydrologic features (watercourses, seeps, springs, wetlands)
- Critical coarse sediment yield areas to be protected
- Existing topography
- Existing and proposed site drainage network and connections to drainage offsite
- Proposed grading
- Proposed impervious features
- Proposed design features and surface treatments used to minimize imperviousness
- Point(s) of Compliance (POC) for Hydromodification Management
- Existing and proposed drainage boundary and drainage area to each POC (when necessary, create separate exhibits for pre-development and post-project conditions)
- Structural BMPs for hydromodification management (identify location, type of BMP, and size/detail)

Please provide the Exhibit in 24"x36" format with map pocket, wet date, and stamp.





LEGEND

PROPERTY LINE	
RIGHT-OF-WAY	
CENTERLINE OF ROAD	
EXISTING FLOW PATH	
FLOW DIRECTION	
EXISTING MAJOR BASIN BOUNDARY	
EXISTING DMA BOUNDARY	
EXISTING IMPERVIOUS AREA	

DMA-1
= 181,197 SF
= 4.16 AC

DMA-2
= 195,689 SF
= 4.49 AC

N 56°05'31" W 905.95'

GUAJOME LAKE ROAD

N 45°40'08" E 977.17'

N 33°42'47" E 895.90'

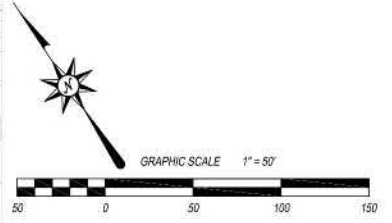

PLAN VIEW - EXISTING DMA MAP
SCALE: 1" = 50'

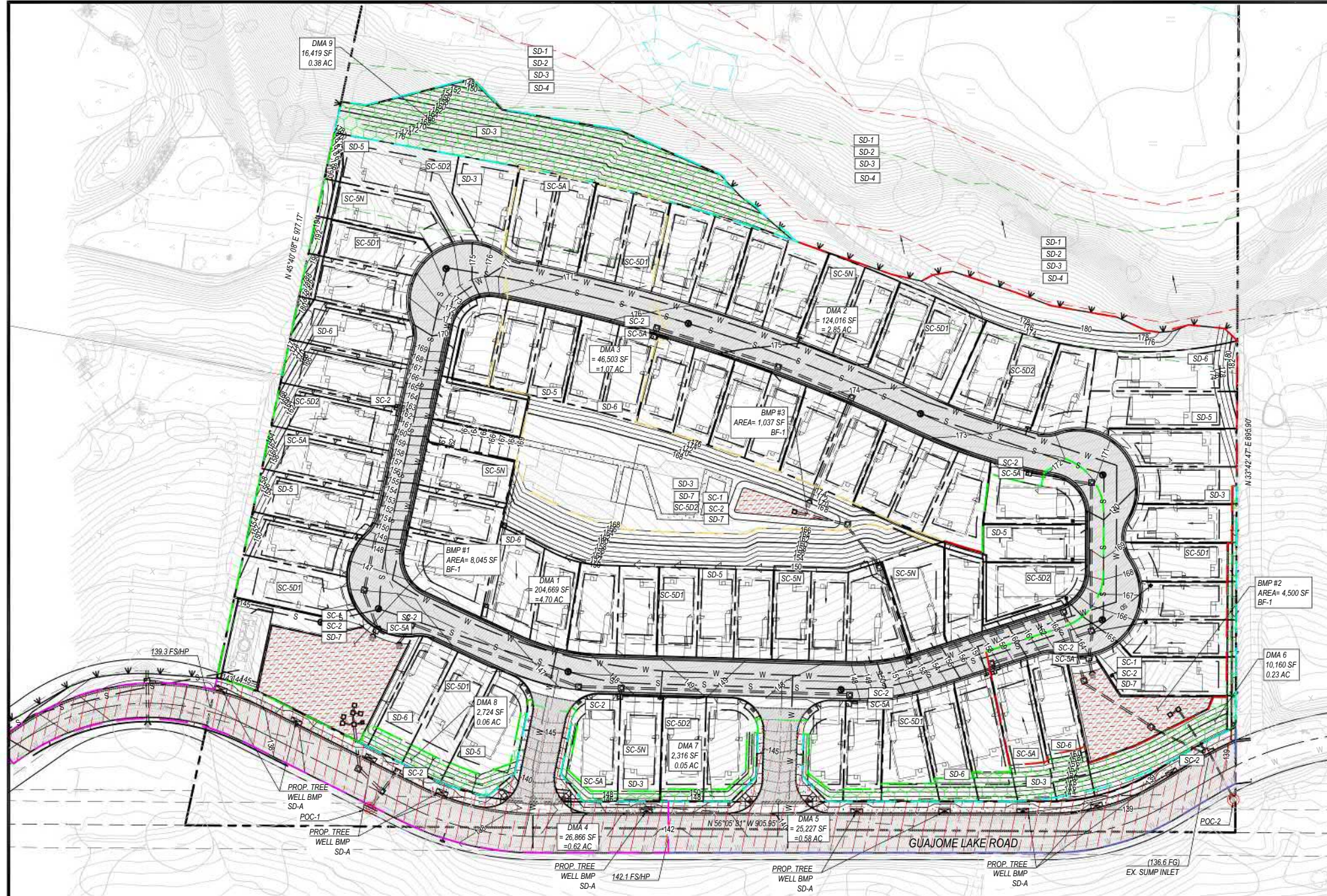

LEGEND

- PROPERTY LINE
- RIGHT-OF-WAY
- CENTERLINE OF ROAD
- EXISTING CONTOUR LINE
- PROPOSED CONTOUR LINE
- FLOW DIRECTION
- PROPOSED DMA 1 BOUNDARY
- PROPOSED DMA 2 BOUNDARY
- PROPOSED DMA 3 BOUNDARY
- PROPOSED DMA 4 BOUNDARY
- PROPOSED DMA 5 BOUNDARY
- PROPOSED SELF-MITIGATING DMA BOUNDARY PER SECTION 5.21 OF OCEANSIDE BMP DESIGN MANUAL
- PROPOSED IMPERVIOUS AREA TO BE ROUTED TO TREE WELL BMPs OR COMPARABLE LID BMP FOR TREATMENT PER GREEN STREET STANDARDS
- PROPOSED BIOFILTRATION BASIN
- PROPOSED TREE WELL BMP (4' X 10')
- POINT OF COMPLIANCE (POC)

PROJECT ONSITE - AREA CALCULATIONS

TOTAL AREA	458,900 SF (10.38 AC)
PROPOSED IMPERVIOUS AREA	281,300 SF (6.46 AC)
PROPOSED PERVIOUS AREA	177,600 SF (4.08 AC)
IMPERVIOUS %	61.3%

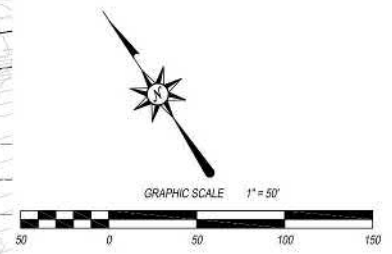

SOIL TYPE INFORMATION

SOIL TYPE D HYDROLOGIC SOILS PER WEB SOIL SURVEY APPLICATION AVAILABLE THROUGH UNITED STATES DEPARTMENT OF AGRICULTURE

COARSE SEDIMENT YIELD

NO CRITICAL COARSE SEDIMENT YIELD AREAS TO BE PROTECTED. REFER TO PRIORITY DEVELOPMENT PROJECT SWMP PREPARED BY PASCO, LARET, SUITER AND ASSOCIATES. SEE APPENDIX 2 "ANALYSIS OF PCCSYAS FOR GUAJOME RESIDENTIAL PROJECT, OCEANSIDE, CA" PREPARED BY REC CONSULTANTS, DATED NOVEMBER 23, 2021, REVISED AUGUST 31, 2022.

GROUNDWATER INFORMATION

GROUND WATER DEPTH IS GREATER THAN 20 FEET.

TREATMENT CONTROL BMPs

BIOFILTRATION	BF-1
TREE WELL	SD-1

PLAN VIEW - HMP EXHIBIT
SCALE: 1" = 50'



PREPARED BY:
PASCO LARET SUITER & ASSOCIATES
San Diego | Encinitas | Orange County
Phone 858.259.8212 | www.plsaengineering.com

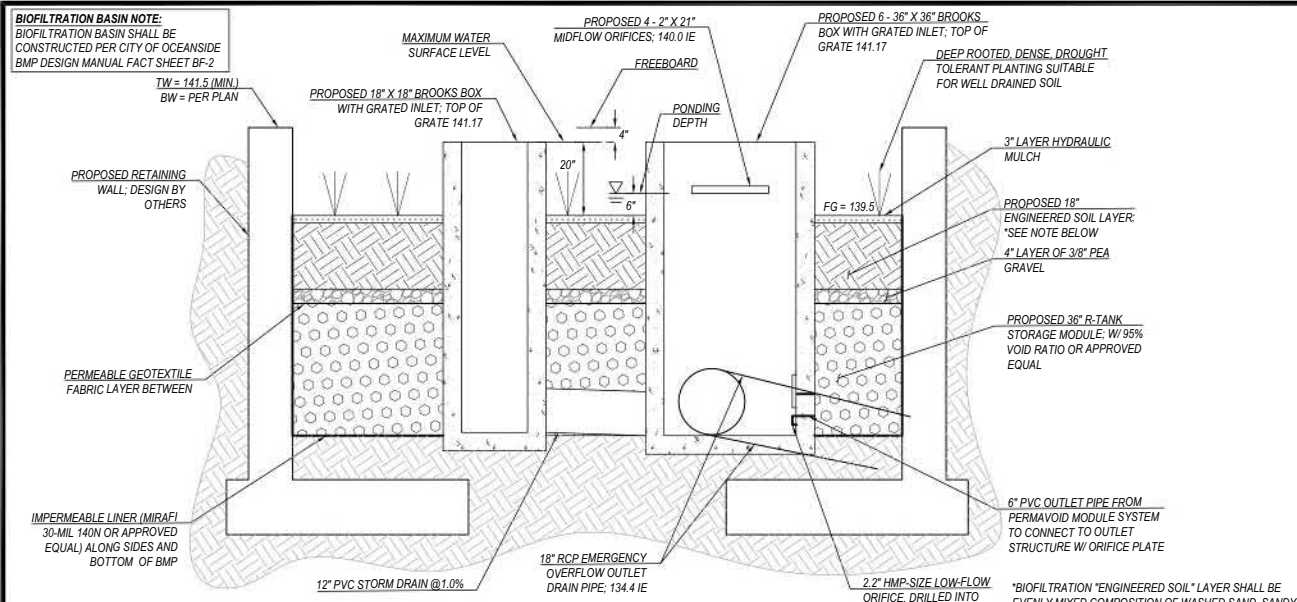

TYPICAL DETAIL - BMP 1 BIOFILTRATION BASIN

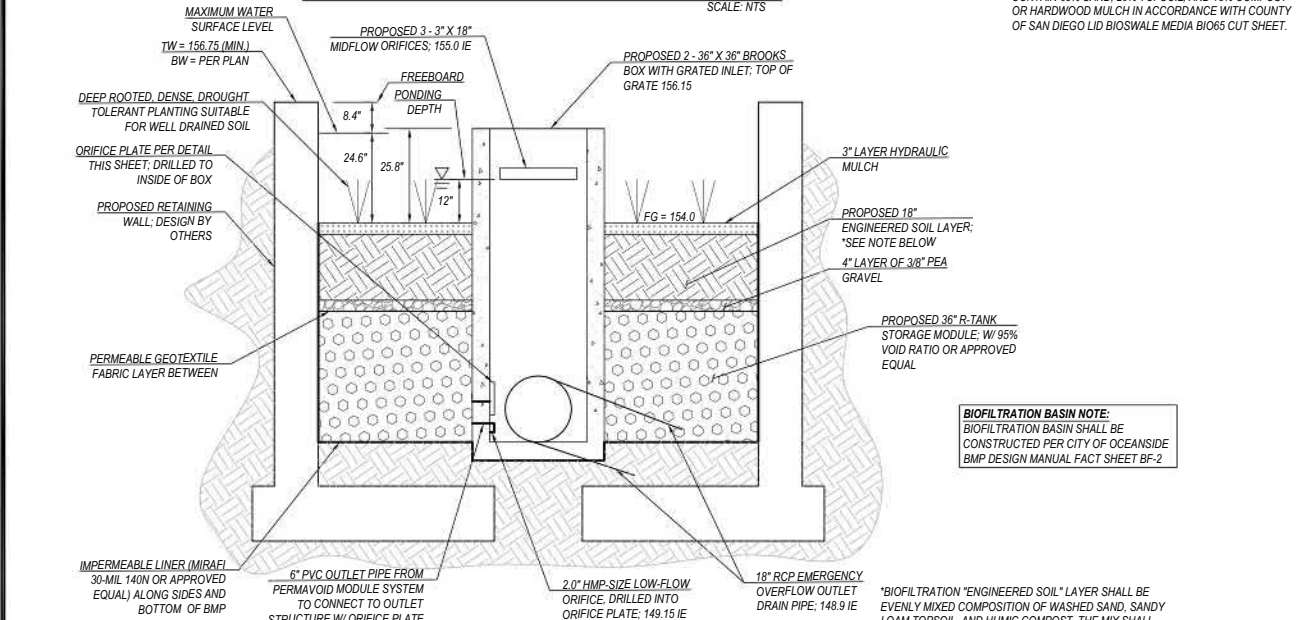

TYPICAL DETAIL - BMP 2 BIOFILTRATION BASIN

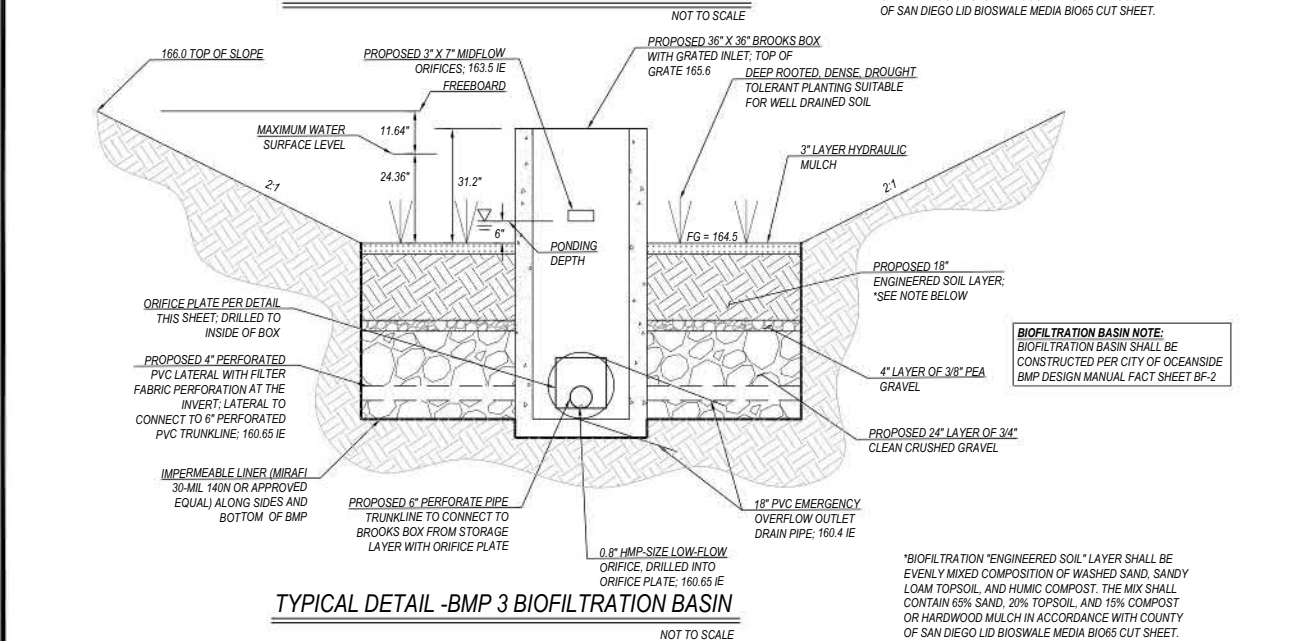

TYPICAL DETAIL - BMP 3 BIOFILTRATION BASIN

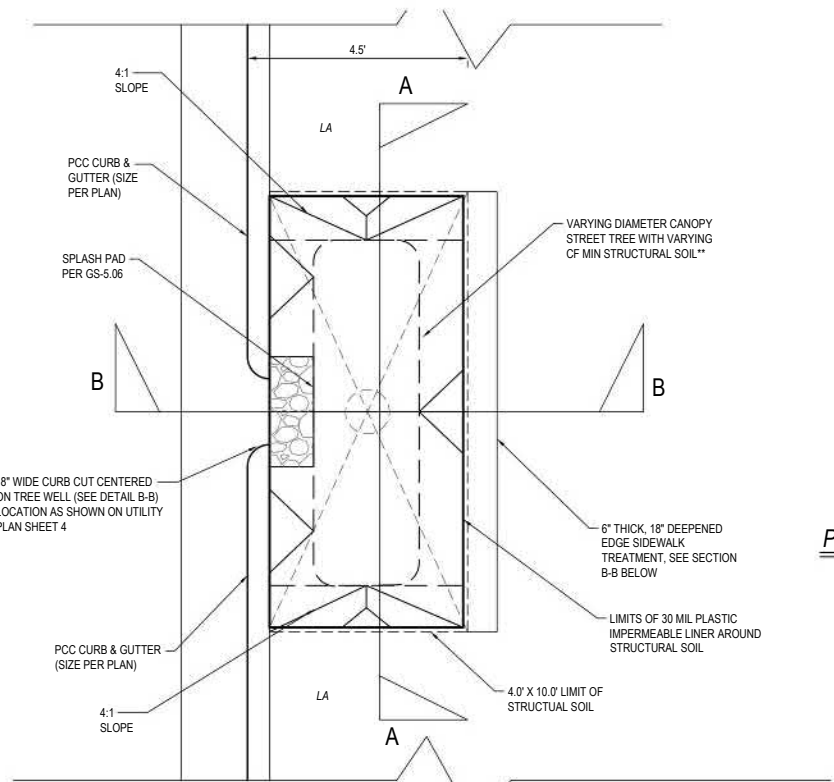

PLAN VIEW - CURB CUT @ TREE WELL SDC GS DS GS-5.01

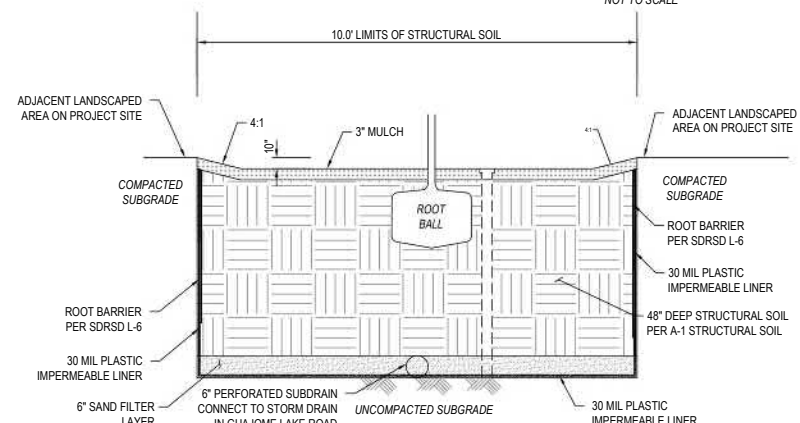

SECTION A-A TREE WELL W/O GRATE MODIFIED SDC GS DS SD-1.04A + GS-1.04B

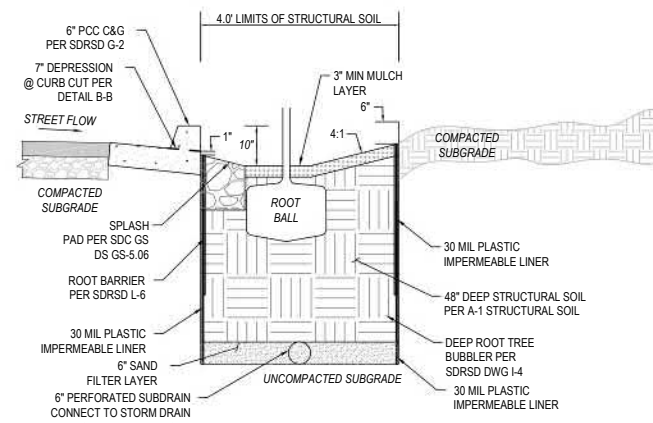

SECTION B-B TREE WELL W/O GRATE MODIFIED SDC GS DS SD-1.04A + GS-1.04B

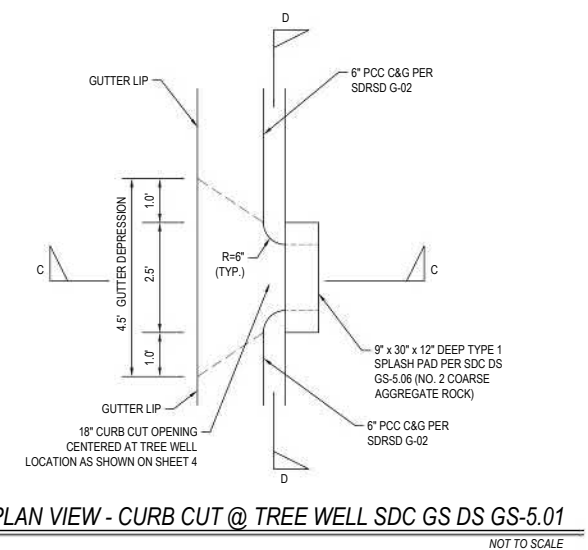

PLAN VIEW - CURB CUT @ TREE WELL SDC GS DS GS-5.01

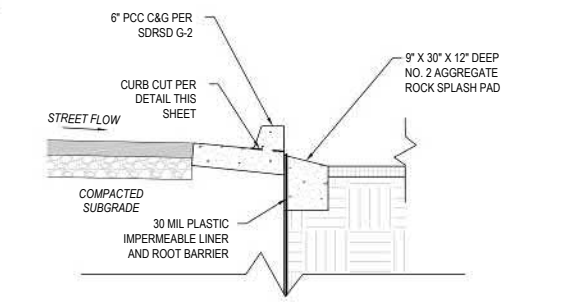

SECTION C-C CURB CUT @ TREE WELL SDC GS DS GS 5.01

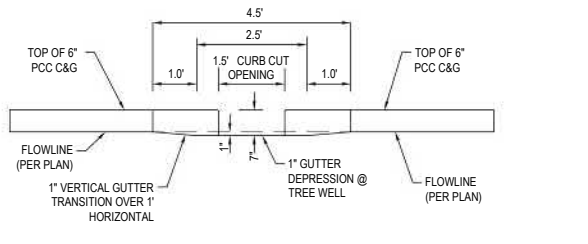

SECTION D-D CURB CUT @ TREE WELL SDC GS DS GS 5.01

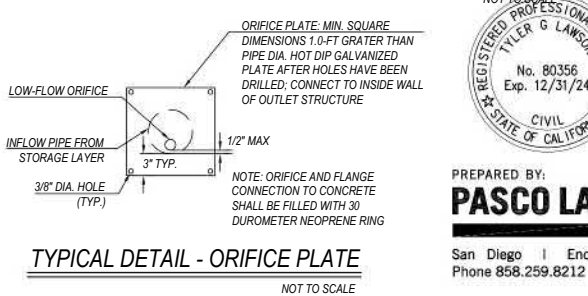

TYPICAL DETAIL - ORIFICE PLATE



PREPARED BY:
PASCO LARET SUITER & ASSOCIATES
 San Diego | Encinitas | Orange County
 Phone 858.259.8212 | www.plsengineering.com

Placeholder – **WMAA Exhibit**

Replace placeholder with required exhibit.



Placeholder – **6.2.1 Verification of GLUs Onsite** (if applicable)

Replace placeholder with required calculations/documentation.

Leave placeholder intact if not applicable.

Not Applicable



Downstream Systems Sensitivity to Coarse Sediment		Form I-10	
When it has been determined that potential critical coarse sediment yield areas exist within the project site, the next step is to determine whether downstream systems would be sensitive to reduction of coarse sediment yield from the project site. Use this form to document the evaluation of downstream systems requirements for preservation of coarse sediment supply.			
Project Name:			
Project Tracking Number / Permit Application Number:			
1	Will the project discharge runoff to a hardened MS4 system (pipe or lined channel) or an un-lined channel?	Hardened MS4 system	Go to 2
		Un-lined channel	Go to 4
2	Will the hardened MS4 system convey sediment (e.g., a concrete-lined channel with steep slope and cleansing velocity) or sink sediment (e.g., flat slopes, constrictions, treatment BMPs, or ponds with restricted outlets within the system will trap sediment and not allow conveyance of coarse sediment from the project site to an un-lined system).	Convey	Go to 3
		Sink	Go to 7
3	What kind of receiving water will the hardened MS4 system convey the sediment to?	Un-lined channel	Go to 4
		Lake Reservoir Bay	Go to 7
		Lagoon Ocean	Go to 6
4	Is the un-lined channel impacted by deposition of sediment? This condition must be documented by the local agency.	Yes	Go to 7
		No	Go to 5



5	End – Preserve coarse sediment supply to protect un-lined channels from accelerated erosion due to reduction of coarse sediment yield from the project site unless further investigation determines the sediment is not critical to the receiving stream. Sediment that is critical to receiving streams is the sediment that is a significant source of bed material to the receiving stream (bed sediment supply) (see Section 6.2.3 and Appendix H.2 of the manual).
6	End – Provide management measures for preservation of coarse sediment supply (protect beach sand supply).
7	End – Downstream system does not warrant preservation of coarse sediment supply, no measures for protection of critical coarse sediment yield areas onsite are necessary. Use the space below to describe the basis for this finding for the project.



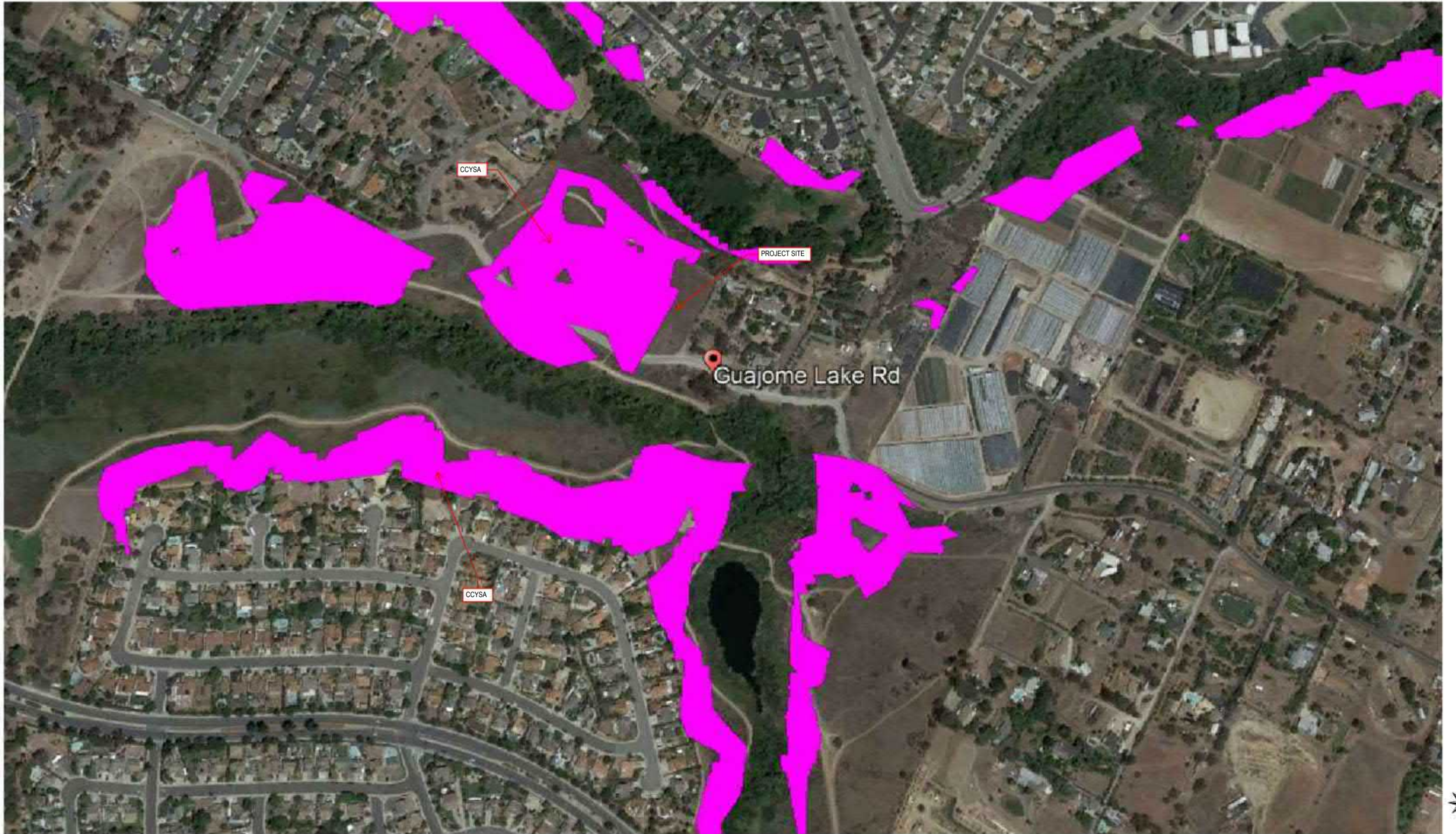

POTENTIAL CCYSA EXHIBIT
NOT TO SCALE

POTENTIAL CCYSA EXHIBIT
2837 GUAJOME LAKE ROAD

PASCO LARET SUITER
& ASSOCIATES
San Diego | Solana Beach | Orange County
Phone 858.259.8212 | www.plsaengineering.com

TECHNICAL MEMORANDUM:

Analysis of PCCSYAs for Guajome Residential Project. Oceanside, CA.

Prepared For:

Rincon Homes.

November 23rd, 2021. Revised: August 31st, 2022.

Prepared by:



Luis Parra, PhD, CPSWQ, ToR, D.WRE.
R.C.E. 66377



REC Consultants
2442 Second Avenue
San Diego, CA 92101
Telephone: (619) 232-9200



ANALYSIS OF PCCSYAs FOR GUAJOME RESIDENTIAL PROJECT, OCEANSIDE, CA

1. OBJECTIVE

The purpose of this Technical Memo is to demonstrate that the Guajome Residential project generates a No Net Impact in the Critical Coarse Sediment Yield for the Guajome Creek and a parallel unnamed tributary (called East Channel Creek in this report). The methodology explained in Appendix H of the County of San Diego BMP Design Manual [1] (including threshold analyses at the receiving streams were the property drains) will help to conclude that the **Potential Critical Coarse Sediment Yield Areas (PCCSYAs)** within the Guajome Residential project are not significant downstream and can be removed from Critical Designation, and their removal will not impact negatively the receiving stream (Guajome and East Channel Creeks) and downstream Guajome Lake.

2. METHODOLOGY TO IDENTIFY CCSYAs

2.1 Identification of CCSYAs

The Watershed Management Area Analysis (WMAA) PCCSYA Map prepared by the County of San Diego is used in Figure 1 to identify PCCSYA in the project area (green line added). From Figure 1 it is clear that a large portion of the developable area is considered PCCSYA. Further refinement options will be applied to determine if PCCSYA areas become CCSYAs or Non-CCSYAs.



Figure 1. Location of PCCSYAs in Green Oak Villas (Brown Area Mass-graded)



Figure 2. Conceptual Site Plan

2.2 Refinement Options

2.2.1 Depositional Analysis

If it can be demonstrated that the potential source of coarse sediment is deposited in existing system prior to reaching the first downstream unlined water of the state, then PCCSYA can be removed from further considerations. Depositional systems may include natural sinks, existing structural BMPs, existing hardened MS4 systems or other existing similar features that produce a peak velocity from the discrete 2-year, 24 hour runoff event of less than 3 ft/s in the system being analyzed.

Figure 2 shows the site plan (conceptual), while Figure 3 shows the overall drainage patter around the development. There is a major riparian system to the north of the property that drains about half of the property (north of the ridge line in red) while the other half drains to the south, into the even larger Guajome Creek. Both creeks end up draining into the Guajome Lake + Wetland.



Figure 3. Drainage Patter around Property

The depositional analysis in this section, (1) will determine an approximate 2 year peak flow velocity, based on Streamstats, a program developed by the USGS (results in Appendix 1), and (2) will demonstrate that those velocities (in both creeks) are less than the velocity required to transport coarse sediments (3 ft/s) because of the following factors: (a) abundant vegetation that slows down the velocity (increases Manning’s n coefficient); and (b) flat overall slope combined with very wide main channel that spreads the flow, reduces the water elevation and consequently reduces the velocity.

It should be pointed out that Appendix H requires the discrete 2 year-24 hour runoff event generates a velocity less than 3 ft/s, while Streamstats from the US Geological Survey determines a 2 year peak flow using a statistical analysis based on drainage area and annual precipitation. For those tributaries (Guajome Creek and East Channel Creek) the contributing areas are 2.3 sq-miles and 1.5 sq-miles respectively, so an analysis of the discrete 2 year – 24 hour storm will be regional in nature and out of the scope of this report. Therefore, velocities will be determined with a more generic approach, and the strength of the velocity assumption tested with a sensitivity analysis.

2.2.1.1 Assumptions for Depositional Analysis

The following is the list of main assumption of this section to understand the results of Appendix 1:

- 1) Peak flow is determined with Streamstat, a USGS program that provides a range of peak values ($Q_{max,T}$, $Q_{min,T}$) and an average expected value Q_{USGS} for a given return period T. Q_{USGS} coincides with the geometric mean of the extreme values [$Q_{USGS} = (Q_{max,T} \cdot Q_{min,T})^{0.5}$].

- 2) For $T = 10$ years, Q_{10} can be determined from equation H.7-5 of the BMP Manual, such that the value $Q_{10} = 18.2 \cdot AF \cdot A^{0.87} \cdot P^{0.77}$. Q_{10} belongs to the range ($Q_{\max,10}$, $Q_{\min,10}$); consequently, an exponent m can be found so that in a log-log interpolation, Q_{10} is linearly associated with $Q_{\max,10}$ and $Q_{\min,10}$ according to: $Q_{10} = Q_{\min,10}^m \cdot Q_{\max,10}^{(1-m)}$. The exponent m can be calculated for the 10 year peak flow of both Guajome Creek and the East Channel Creek
- 3) The value of m from 2) is assumed unchanged for the 2 year peak flow. Therefore, the value of $Q_{2,m}$ can be calculated by a log-log interpolation with the exponent m and can be considered analogous to equation H.7-5: $Q_{2,m} = Q_{\min,2}^m \cdot Q_{\max,2}^{(1-m)}$. The value calculated this way is larger than the corresponding $Q_{2,USGS}$ and is considered sufficiently representative of the Q_2 value needed for the depositional analysis ($Q_{2,m} > Q_{2,USGS}$)
- 4) Geometric properties of the receiving creek (width W , slope s) are approximately taken from topographic maps (see Appendix 1), while the Manning's coefficient n is assumed conservatively small (0.05) as to increase within a reasonable margin the 2 year velocity.
- 5) The peak flow needed to reach a velocity of 3 ft/s is also calculated, to determine how confident we are that the results are representative of a depositional analysis.

2.2.1.2 Results

Results are shown in Appendix 1. For the Guajome Creek, the velocity for $Q_{2,m}$ is very low (1.08 ft/s) and the flow needed to reach a velocity of 3 ft/s is extremely high (1412 cfs, much larger than any statistical estimation of Q_2). Therefore, Guajome Creek is certainly a depositional creek and all PCCSYAs draining to it will become Non-CCSYAs.

For the East Channel Creek the Manning's velocity for $Q_{2,m}$ is low ($v_2 = 2.84$ ft/s) even considering a low n value and a high value of Q_2 (tied to a low exponent m indirectly associated with a high Q_{10}). However, there is still certain level of uncertainty as the flow needed for the velocity to reach 3 ft/s (97.4 cfs) is within the USGS expected range (6.16, 198) even if it is almost 3 times larger than $Q_{2,USGS}$ (= 34.9 cfs). Therefore, there is a moderate to high certainty that the East Channel Creek is a depositional creek.

2.2.1.3 Additional considerations in regards to Guajome Lake

It is physically impossible to allow the transport of coarse sediment (assuming there is some coarse sediment to transport) without allowing at the same time the transport of finer sediment, as the later requires smaller velocities to be transported than the former. According to the City of Oceanside official web page [2], Guajome Lake is impaired by sediments and nutrients, so even if the creeks contributing to it were to need coarse sediments, any sediment excess will end up in Guajome Lake. Guajome Lake is deemed a sink from the sediment transport point of view; therefore, this is another reason to consider the entire system as depositional.

It is important to emphasize that Guajome Lake itself could be considered far enough downstream from the environmental point of view as to unequivocally justify the elimination of coarse sediment transport between the property and the lake; thus, the depositional nature of the Guajome Creek and the East

Channel Creek tributary were considered as additional factors to further enhance the depositional characteristic of the natural drainage network downstream of the proposed Guajome Residential Project, but not as the only factor; hence, the analysis of section 2.2.1.2.

2.2.1.4 Conclusion of the Depositional Analysis

From this section it is evident that Guajome Creek is a depositional Creek while the East Channel Creek to the north most likely is also a depositional creek.

To further strengthen the point that all PCCSYAs in the property will eventually become Non-CCSYAs, a threshold analysis of the receiving creeks (Guajome and East Channel) was also performed in the section 2.2.2.

2.2.2 Threshold Channel Analysis

An approximate threshold channel analysis was performed. The following are the assumptions and results (see detailed results in Appendix 2):

- As the channel is heavily vegetated, non-erosive, depositional (in some areas, see Appendix 2) and of difficult access, a d_{50} measurement (typical of non-cohesive granular channels) does not make sense. Consequently a Fischenich (2001) shear stress equivalence between cohesive-vegetated channels and non-cohesive d_{50} channels will be carried out for the City of Oceanside consideration as (a) it is the only option in this case; and (b) this equivalent method has been used successfully in determining if a creek is low, medium or high susceptibility.
- According to Fischenich (Figure 5-1, HMP Document, [3]) the shear stress can be as high as 1.2 – 1.7 lb/ft² (long native grasses), have an intermediate level of 0.41-2.5 lb/ft² (hardwood tree planting), a lower value for reed (0.1 – 0.6 lb/ft²) or a more concrete value for shales and hardpan soil (0.67 lb/ft²). Taking into account that mostly heavy vegetation was found in both the Guajome Creek and the East Channel Creek a conservative value of 0.50 lb/ft² will be used (a high value for reed but below the low value for short and long native grasses). This shear stress is equivalent to the shear stress that a diameter of $d_{50} = 1.2$ inches can resist (diameter is numerically equal to about 2.4 times the numerical value of the shear stress, per the gravel/cobble values of Fischenich Table included in Appendix 2).
- Specific Stream Power (SSP) will be obtained as $SSP = \gamma \cdot Q \cdot s / W$ ($\gamma = 9810 \text{ N/m}^3$; Q in m^3/s ; $s = \text{ft}/\text{ft} = \text{m}/\text{m}$; W – average width, meters).
- The SSP vs d_{50} plots as a single point in the Braided Equilibrium plot of Appendix H, Figure H.7.1. In both cases, the point is below the braided equilibrium line.
- Appendix 2 also calculates the diameter needed to be in Braided equilibrium per equation included in Figure H.7.1: $SSP = 16.7 \cdot d_{50}^{0.75}$ (SSP in watt/m^2 ; d_{50} in mm). The value of d_{50} was obtained, which is very small for the Guajome Creek (Only 0.29 mm) and small for the East Channel Creek (8.5 mm), both values smaller than the equivalent diameter of 30.5 mm.

2.2.2.1. Conclusions of Threshold Channel Analysis

Both channels (Guajome Creek and East Channel Creek) are preliminarily threshold channels (more so Guajome Creek than the East Channel Creek). Therefore, at the downstream location analyzed near the property, both do not need CCSYAs for functioning and the adjacent PCCSYAs do not need to be protected; consequently, all PCCSYAs in the property can be considered Non-CCSYAs.

An important note: the results of this section are tied to the precision in the assumption that connects d_{50} with acceptable shear stress under different surfaces. It should be pointed out that Fischenich approximation has been accepted as valid by the Water Board in many analyses, especially related with low and medium susceptibility analyses of multiple creeks along San Diego County.

2.2.3 Coarse Sediment Source Area Verification

If the project demonstrates that the PCCSYAs consist mainly of fine grained sediment, the project may be removed from consideration (in other words PCCSYAs areas in the project become Non-CCSYAs areas). Currently the criterion is that the applicant can exclude PCCSYAs that are determined to be fine grained ($d_{50} < 0.074$ mm). Coarse grained is defined as over 50% by weight coarser than no. 200 sieve (0.074 mm).

Sieve analyses have not been made in the project. However, they are not necessary as sections 2.2.1 and 2.2.2 yield positive results to transform PCCSYAs into Non-CCSYAs.

2.2.4 Verification of Geomorphic Landscape Units (GLUs)

GLU analysis was not performed in detail, but a quick verification of the slope, land use and geology of the project size confirms that GLU analysis will modify or reduce but not remove PCCSYA areas (see Appendix 3). Therefore, the specific GLU analysis was not completed for this project as it is considered unnecessary since sections 2.2.1 and 2.2.2 yield positive results to transform PCCSYAs into Non-CCSYAs.

3. AVOIDANCE AND BYPASS + NO NET IMPACT

Avoidance of PCCSYAs is not necessary as the areas have been designed as Non-CCSYAs per section 2.2.1 and 2.2.2. A No Net Impact Analysis is not necessary for the same reason; therefore, these 2 options are not further explored as they are unnecessary.



4. CONCLUSIONS OF THE STUDY

- 1) The Guajome Creek and the East Channel Creek downstream of the project area are considered depositional, as the velocities for the 2 year storm are less than 3 ft/s. Also, there are plenty of opportunities for the drainage system to trap coarse sediment, especially in Guajome Lake and the marsh adjacent to it. **This conclusion in itself should be sufficient to exclude the PCCSYAs to discharge into Guajome Creek or the East Channel Creek as those areas will become Non-CCSYAs from this analysis.** However, uncertainty in the Q_2 methodology leads to an additional threshold analysis to strengthen the analysis.

- 2) Both Guajome Creek and the East Channel Creek to the north of the property are considered to be threshold creeks in the Range of Analysis. Preliminary calculations performed here suggest that the 10-yr Specific Stream Power and the Equivalent Median Grain Diameter (of two creeks who are not granular and therefore not subject to normal grain size counting) are below the power law line identified in Figure H.7-1. **This criterion alone transforms the PCCSYAs (draining to both the East Channel Creek and to Guajome Creek) into Non-CCSYAs.**

5. LIST OF APPENDICES

Appendix 1: Depositional Analysis: (a) USGS Streamstats Results. (b) Result of Calculations

Appendix 2: Threshold Analysis: (a) Fischenich Table. (b) Result of Calculations.

Appendix 3: GLU Analysis Figures

6. REFERENCES

- [1] Appendix H: Guidance for Investigation Potential Critical Coarse Sediment Yield Areas: https://www.sandiegocounty.gov/content/dam/sdc/dpw/WATERSHED_PROTECTION_PROGRAM/watershedpdf/Dev_Sup/BMPDM_AppH_Sep2020.pdf
- [2] https://www.ci.oceanside.ca.us/gov/water/services_programs/clean/mass/guajome.asp: Guajome Creek web page.
- [3] Brown and Cadwell: Final Hydromodification Management Plan. Prepared for County of San Diego, CA. January 13, 2011.



7. RESPONSE TO REVIEWER COMMENTS RELATED TO 11/23/2021 VERSION

- Page 1: Provide this study in the SWQMP with next submittal

Study to be included as an appendix of the SWQMP.

- Page 2: Please Identify water body as East Channel Creek throughout report

Report will change Unnamed Creek by East Channel Creek as suggested.

- Page 3: Figure 2 does not appear to be Current. Please revise accordingly.

Figure has been updated.

- Page 4: Values appear to be in wrong order. Please reverse values to agree with the streamstats report.

Reviewer is correct. Numbers have been placed in the right order.

- Page 5: Please provide an exhibit depicting the locations of the representative sections. Please also provide the geometry of the typical section in Appendix 1.

An exhibit with the approximate location of some sections has been added to Appendix 1. The geometry is rectangular because for the width determined the depth is less than 2 ft (elevation between consecutive contour lines) and also the threshold channel methodology is based on rectangular sections.

The reviewer should be aware that no specific section was used for calculations. Rather, an average of the width and the slope was taken so that those properties are a representation of average conditions because the slope and the width change along the receiving creeks. In order to give strength to the argument, a sensitivity analysis has been made to determine the conditions of an extreme section in Guajome Creek ($W = 280$ ft, $s = 1\%$) and East Channel Creek ($W = 24$ ft; $s = 2\%$). In both cases, Threshold Channel Conditions are still prevalent so the Threshold Channel argument is strong regardless of the width and slope variation.

- Page 6: have any of these assumptions field verified?

There is no need for field verification in this specific project because the dense vegetation is evident in aerial pictures, and can be observed in Google pictures included in Appendix 2. Also, the author has driven around N. Santa Fe Avenue and the density of vegetation can be observed any time of the year. The cohesive and conglomerated description in the text has been eliminated to avoid descriptions that (a) are unnecessary for the Non-CCSYA designation according to the methods used, and (b) are not tied to a soil analysis or field verification (that is impossible given the vegetation density).

- Page 17 and Page 18 (same comments): please provide basis for assumption (about imperviousness). As this analysis is highly dependent upon the channel vegetation, it seems justifiable that the channel vegetation condition is field verified.

In regards to impervious percentages: they have been updated following a more comprehensive StreamStats report prepared for Guajome and East Channel Creeks. All calculations have been updated as well.

In regards to channel vegetation, it has been observed in the field (no pictures included) but is also observed in Google Earth (new pictures added to Appendix 2).

- Page 21: Information Only: Per the project biological resources report, it appears that the existing site land cover has been identified as “developed” and “non-native grassland”. Consider referencing the biological resources report to conduct an analysis verification of GLUs onsite to determine if PCCSYA classification is valid. Please refer to City of Oceanside BMP design Manual Appendix H, Table H.1-2 for site-specific GLU land cover groupings.

Per section 2.2.4 of the report, a GLU analysis was not performed because the conservative approach using the slope analysis and the GLU figure of Appendix 3 does not eliminate PCCSYAs. No attempt to use site-specific information (such as that of the Biological Resources Report) was pursued because the author believed the SanGIS land cover is more conservative in this project. In any case, the use of the Biological report information (that was not available to the author of this report when it was prepared) is independent of the threshold analysis (which is creek dependent) or the depositional analysis and will never contradict those 2 analysis made. Per Appendix H requirements, only one (1) positive response for the exemptions is needed, and this report provides two (2). Proving a third via a more detailed GLU is unnecessary here (it might have been useful before this report was prepared) and consequently the recommendation from the comment is appreciated but not needed. No modifications are required because of this comment.

Appendix 1: Depositional Analysis

- USGS Stream-stats Results (updated)
- Location of Sections on Guajome and East Channel Creeks
- Result of Calculations (Depositional Analysis)

StreamStats Report

Region ID: CA

Workspace ID: CA20220831172701553000

Clicked Point (Latitude, Longitude): 33.24147, -117.26322

Time: 2022-08-31 13:27:25 -0400

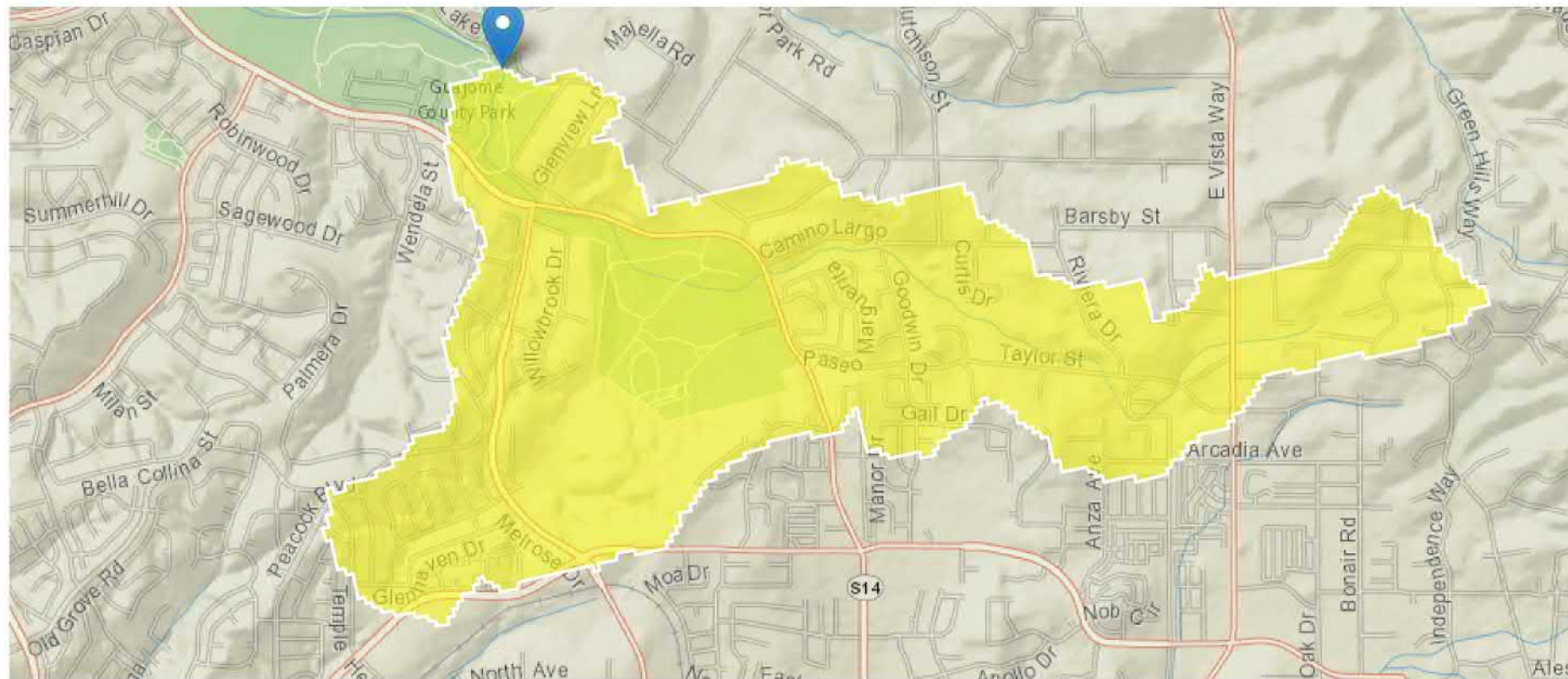

+ Collapse All

➤ Basin Characteristics

Parameter Code	Parameter Description	Value	Unit
BASINPERIM	Perimeter of the drainage basin as defined in SIR 2004-5262	12.7	miles
BSLDEM30M	Mean basin slope computed from 30 m DEM	9.08	percent
DRNAREA	Area that drains to a point on a stream	2.3	square miles
EL6000	Percent of area above 6000 ft	0	percent
ELEV	Mean Basin Elevation	374	feet
ELEVMAX	Maximum basin elevation	804	feet
FOREST	Percentage of area covered by forest	3.83	percent
LAKEAREA	Percentage of Lakes and Ponds	0.0892	percent
LC11DEV	Percentage of developed (urban) land from NLCD 2011 classes 21-24	86.5	percent
LC11IMP	Average percentage of impervious area determined from NLCD 2011 impervious dataset	33	percent
LFPLENGTH	Length of longest flow path	4	miles
PRECIP	Mean Annual Precipitation	14.7	inches
RELIEF	Maximum - minimum elevation	674	feet
RELRELF	Basin relief divided by basin perimeter	53.2	feet per mi

➤ Peak-Flow Statistics

Peak-Flow Statistics Parameters [2012 5113 Region 5 South Coast]

Parameter Code	Parameter Name	Value	Units	Min Limit	Max Limit
-----------------------	-----------------------	--------------	--------------	------------------	------------------

Parameter Code	Parameter Name	Value	Units	Min Limit	Max Limit
DRNAREA	Drainage Area	2.3	square miles	0.04	850
PRECIP	Mean Annual Precipitation	14.7	inches	10	45

Peak-Flow Statistics Flow Report [2012 5113 Region 5 South Coast]

PII: Prediction Interval-Lower, Plu: Prediction Interval-Upper, ASEp: Average Standard Error of Prediction, SE: Standard Error (other -- see report)

Statistic	Value	Unit	PII	Plu	ASEp
50-percent AEP flood	47.7	ft ³ /s	8.53	267	134
20-percent AEP flood	143	ft ³ /s	42	487	83.1
10-percent AEP flood	223	ft ³ /s	82.4	604	64
4-percent AEP flood	327	ft ³ /s	143	749	51.5
2-percent AEP flood	410	ft ³ /s	190	883	47.6
1-percent AEP flood	495	ft ³ /s	229	1070	47.2
0.5-percent AEP flood	587	ft ³ /s	269	1280	47.7
0.2-percent AEP flood	693	ft ³ /s	302	1590	52

Peak-Flow Statistics Citations

Gotvald, A.J., Barth, N.A., Veilleux, A.G., and Parrett, Charles, 2012, Methods for determining magnitude and frequency of floods in California, based on data through water year 2006: U.S. Geological Survey Scientific Investigations Report 2012-5113, 38 p., 1 pl. (<http://pubs.usgs.gov/sir/2012/5113/>)

USGS Data Disclaimer: Unless otherwise stated, all data, metadata and related materials are considered to satisfy the quality standards relative to the purpose for which the data were collected. Although these data and associated metadata have been reviewed for accuracy and completeness and approved for release by the U.S. Geological Survey (USGS), no warranty expressed or implied is made regarding the display or utility of the data for other purposes, nor on all computer systems, nor shall the act of distribution constitute any such warranty.

USGS Software Disclaimer: This software has been approved for release by the U.S. Geological Survey (USGS). Although the software has been subjected to rigorous review, the USGS reserves the right to update the software as needed pursuant to further analysis and review. No warranty, expressed or implied, is made by the USGS or the U.S. Government as to the functionality of the software and related material nor shall the fact of release constitute any such warranty. Furthermore, the software is released on condition that neither the USGS nor the U.S. Government shall be held liable for any damages resulting from its authorized or unauthorized use.

USGS Product Names Disclaimer: Any use of trade, firm, or product names is for descriptive purposes only and does not imply endorsement by the U.S. Government.

Application Version: 4.10.1

StreamStats Services Version: 1.2.22

NSS Services Version: 2.2.1

StreamStats Report

Region ID: CA

Workspace ID: CA20220831173041292000

Clicked Point (Latitude, Longitude): 33.24391, -117.26247

Time: 2022-08-31 13:31:04 -0400

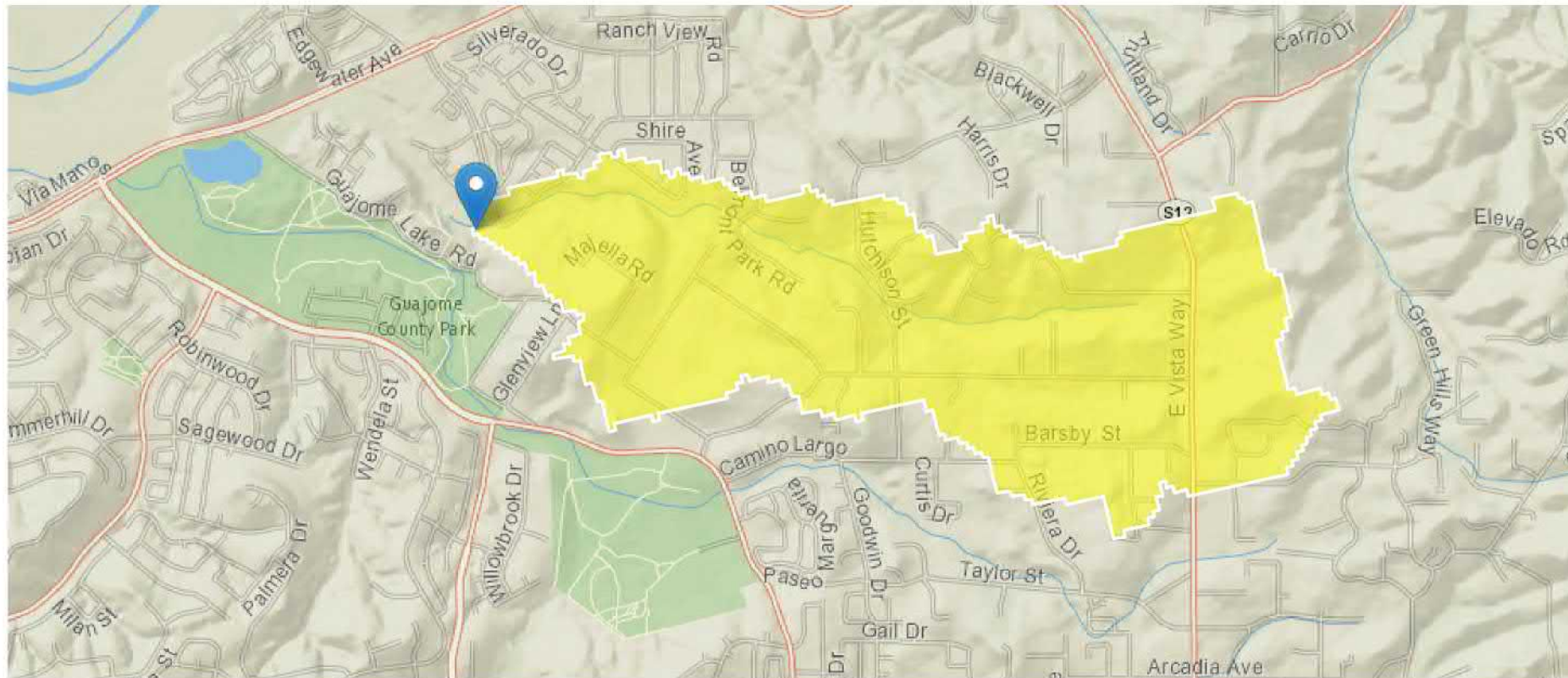

+ Collapse All

➤ Basin Characteristics

Parameter Code	Parameter Description	Value	Unit
BASINPERIM	Perimeter of the drainage basin as defined in SIR 2004-5262	8.76	miles
BSLDEM30M	Mean basin slope computed from 30 m DEM	9.35	percent
DRNAREA	Area that drains to a point on a stream	1.5	square miles
EL6000	Percent of area above 6000 ft	0	percent
ELEV	Mean Basin Elevation	385	feet
ELEVMAX	Maximum basin elevation	711	feet
FOREST	Percentage of area covered by forest	5.89	percent
LAKEAREA	Percentage of Lakes and Ponds	0	percent
LC11DEV	Percentage of developed (urban) land from NLCD 2011 classes 21-24	82.9	percent
LC11IMP	Average percentage of impervious area determined from NLCD 2011 impervious dataset	25.1	percent
LFPLENGTH	Length of longest flow path	3	miles
PRECIP	Mean Annual Precipitation	14.2	inches
RELIEF	Maximum - minimum elevation	567	feet
RELRELF	Basin relief divided by basin perimeter	64.8	feet per mi

➤ Peak-Flow Statistics

Peak-Flow Statistics Parameters [2012 5113 Region 5 South Coast]

Parameter Code	Parameter Name	Value	Units	Min Limit	Max Limit
-----------------------	-----------------------	--------------	--------------	------------------	------------------

Parameter Code	Parameter Name	Value	Units	Min Limit	Max Limit
DRNAREA	Drainage Area	1.5	square miles	0.04	850
PRECIP	Mean Annual Precipitation	14.2	inches	10	45

Peak-Flow Statistics Flow Report [2012 5113 Region 5 South Coast]

PII: Prediction Interval-Lower, Plu: Prediction Interval-Upper, ASEp: Average Standard Error of Prediction, SE: Standard Error (other -- see report)

Statistic	Value	Unit	PII	Plu	ASEp
50-percent AEP flood	34.9	ft ³ /s	6.16	198	134
20-percent AEP flood	101	ft ³ /s	29.3	348	83.1
10-percent AEP flood	154	ft ³ /s	56.3	421	64
4-percent AEP flood	219	ft ³ /s	94.8	506	51.5
2-percent AEP flood	269	ft ³ /s	124	585	47.6
1-percent AEP flood	320	ft ³ /s	147	698	47.2
0.5-percent AEP flood	374	ft ³ /s	170	825	47.7
0.2-percent AEP flood	435	ft ³ /s	187	1010	52

Peak-Flow Statistics Citations

Gotvald, A.J., Barth, N.A., Veilleux, A.G., and Parrett, Charles, 2012, Methods for determining magnitude and frequency of floods in California, based on data through water year 2006: U.S. Geological Survey Scientific Investigations Report 2012-5113, 38 p., 1 pl. (<http://pubs.usgs.gov/sir/2012/5113/>)

USGS Data Disclaimer: Unless otherwise stated, all data, metadata and related materials are considered to satisfy the quality standards relative to the purpose for which the data were collected. Although these data and associated metadata have been reviewed for accuracy and completeness and approved for release by the U.S. Geological Survey (USGS), no warranty expressed or implied is made regarding the display or utility of the data for other purposes, nor on all computer systems, nor shall the act of distribution constitute any such warranty.

USGS Software Disclaimer: This software has been approved for release by the U.S. Geological Survey (USGS). Although the software has been subjected to rigorous review, the USGS reserves the right to update the software as needed pursuant to further analysis and review. No warranty, expressed or implied, is made by the USGS or the U.S. Government as to the functionality of the software and related material nor shall the fact of release constitute any such warranty. Furthermore, the software is released on condition that neither the USGS nor the U.S. Government shall be held liable for any damages resulting from its authorized or unauthorized use.

USGS Product Names Disclaimer: Any use of trade, firm, or product names is for descriptive purposes only and does not imply endorsement by the U.S. Government.

Application Version: 4.10.1

StreamStats Services Version: 1.2.22

NSS Services Version: 2.2.1

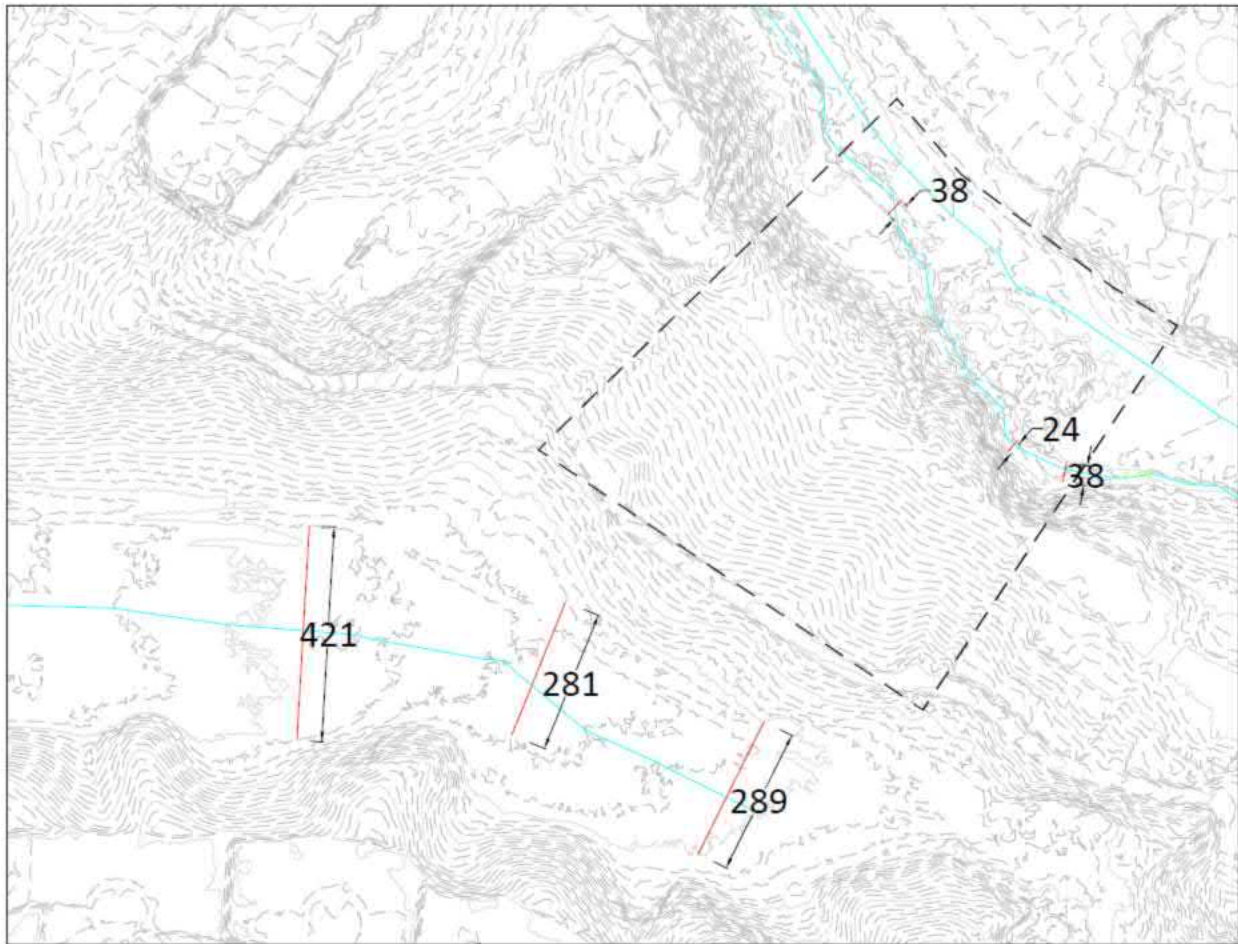

Figure A1. Approximate location of sections in Guajome Creek (SW of property) and East Channel Creek (inside property) in relation to the Guajome Property for the purposes of CCSYAs.

DEPOSITIONAL ANALYSIS

Guajome Creek = South Channel

USGS values	USGS Range		exponent m
	Q _{min}	Q _{max}	
Q ₁₀ :	223 cfs	604	0.249
Q ₂ :	47.7 cfs	267	368
			113

	Expected Q	Max. Q
s:	0.008	0.0080
n:	0.05	0.05
W (ft):	390	390
h (ft):	0.265	1.2065
R _H (ft):	0.264	1.199
v (ft/s):	1.09	3.000
Q (cfs):	113	1412

$$Q_{10} = Q_{\min}^m \cdot Q_{\max}^{(1-m)}$$

Notice that if $m = 0.5$, the USGS peak is obtained
m is found to get Q₁₀ from H.7-3 Eq. (Appendix H)

Note: north channel and south channel have
similar exponent, which attest
to the strength of the interpolation.

Conservative Q₂ per USGS Stream-stats, small n for vegetation (conservative approach).

Velocity significantly below 3 ft/s.

Confidence: **Very high** as Q₂ >> Q_{2,max}.

East Channel Creek = North Channel

USGS values	USGS Range		exponent m
	Q _{min}	Q _{max}	
Q ₁₀ :	154 cfs	421	0.277
Q ₂ :	34.9 cfs	198	241
			76

	Expected Q	Max. Q
s:	0.0142	0.0142
n:	0.05	0.05
W (ft):	40	40
h (ft):	0.698	0.812
R _H (ft):	0.674	0.780
v (ft/s):	2.72	3.000
Q (cfs):	76	97.4

$$Q_{10} = Q_{\min}^m \cdot Q_{\max}^{(1-m)}$$

Notice that if $m = 0.5$, the USGS peak is obtained
m is found to get Q₁₀ from H.7-3 Eq. (Appendix H)

Note: north channel and south channel have
similar exponent, which attest
to the strength of the interpolation.

Conservative Q₂ per USGS Stream-stats, small n for vegetation (conservative approach).

Velocity 5% below 3 ft/s.

Confidence: **Moderate to high** as Q₂ > Q_{2,USGS} but Q₂ < Q_{2,max}.

Both channel velocities (but more so the south channel) are not conducive to
transportation of coarse sediments.

Appendix 2: Threshold Analysis

- Fischenich Table
- Results of Calculations (Threshold Analysis). Includes Results from Sensitivity Analysis
- Google Pictures (Dense Vegetation)

Table 2. Permissible Shear and Velocity for Selected Lining Materials¹

Boundary Category	Boundary Type	Permissible Shear Stress (lb/sq ft)	Permissible Velocity (ft/sec)	Citation(s)	
<u>Soils</u>	Fine colloidal sand	0.02 - 0.03	1.5	A	
	Sandy loam (noncolloidal)	0.03 - 0.04	1.75	A	
	Alluvial silt (noncolloidal)	0.045 - 0.05	2	A	
	Silty loam (noncolloidal)	0.045 - 0.05	1.75 - 2.25	A	
	Firm loam	0.075	2.5	A	
	Fine gravels	0.075	2.5	A	
	Stiff clay	0.26	3 - 4.5	A, F	
	Alluvial silt (colloidal)	0.26	3.75	A	
	Graded loam to cobbles	0.38	3.75	A	
	Graded silts to cobbles	0.43	4	A	
	Shales and hardpan	0.67	6	A	
	<u>Gravel/Cobble</u>	1-in.	0.33	2.5 - 5	A
		2-in.	0.67	3 - 6	A
6-in.		2.0	4 - 7.5	A	
12-in.		4.0	5.5 - 12	A	
<u>Vegetation</u>		Class A turf	3.7	6 - 8	E, N
	Class B turf	2.1	4 - 7	E, N	
	Class C turf	1.0	3.5	E, N	
	Long native grasses	1.2 - 1.7	4 - 6	G, H, L, N	
	Short native and bunch grass	0.7 - 0.95	3 - 4	G, H, L, N	
	Reed plantings	0.1-0.6	N/A	E, N	
	Hardwood tree plantings	0.41-2.5	N/A	E, N	
	<u>Temporary Degradable RECPs</u>	Jute net	0.45	1 - 2.5	E, H, M
Straw with net		1.5 - 1.65	1 - 3	E, H, M	
Coconut fiber with net		2.25	3 - 4	E, M	
Fiberglass roving		2.00	2.5 - 7	E, H, M	
<u>Non-Degradable RECPs</u>		Unvegetated	3.00	5 - 7	E, G, M
	Partially established	4.0-6.0	7.5 - 15	E, G, M	
	Fully vegetated	8.00	8 - 21	F, L, M	
	<u>Riprap</u>	6 - in. d ₅₀	2.5	5 - 10	H
9 - in. d ₅₀		3.8	7 - 11	H	
12 - in. d ₅₀		5.1	10 - 13	H	
18 - in. d ₅₀		7.6	12 - 16	H	
24 - in. d ₅₀		10.1	14 - 18	E	
<u>Soil Bioengineering</u>	Wattles	0.2 - 1.0	3	C, I, J, N	
	Reed fascine	0.6-1.25	5	E	
	Coir roll	3 - 5	8	E, M, N	
	Vegetated coir mat	4 - 8	9.5	E, M, N	
	Live brush mattress (initial)	0.4 - 4.1	4	B, E, I	
	Live brush mattress (grown)	3.90-8.2	12	B, C, E, I, N	
	Brush layering (initial/grown)	0.4 - 6.25	12	E, I, N	
	Live fascine	1.25-3.10	6 - 8	C, E, I, J	
	Live willow stakes	2.10-3.10	3 - 10	E, N, O	
<u>Hard Surfacing</u>	Gabions	10	14 - 19	D	
	Concrete	12.5	>18	H	

¹ Ranges of values generally reflect multiple sources of data or different testing conditions.

A. Chang, H.H. (1988).

F. Julien, P.Y. (1995).

K. Sprague, C.J. (1999).

B. Florineth. (1982)

G. Kouwen, N.; Li, R. M.; and Simons, D.B., (1980).

L. Temple, D.M. (1980).

C. Gerstgraser, C. (1998).

H. Norman, J. N. (1975).

M. TXDOT (1999)

D. Goff, K. (1999).

I. Schiechl, H. M. and R. Stern. (1996).

N. Data from Author (2001)

E. Gray, D.H., and Sotir, R.B. (1996).

J. Schoklitsch, A. (1937).

O. USACE (1997).

Stability Thresholds for Stream Restoration Materials



by Craig Fischenich¹

May 2001

Complexity



Value as a Planning Tool



Cost

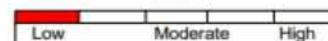

Property measurements, Guajome Creek

W average: 390 ft
 w: 119 m

 Area: 2.3 sq-miles
 Prec: 14.7 inches
 % imperv: 33% (from StreamStats)
 AF: 1.238 (From Figure H.7-2)
 Q₁₀: 368 cfs
 Q₁₀: **10.43** m³/s

 L: 250 ft (average)
 Δz: 2 ft
 s: **0.008** ft/ft
 γ: **9810** N/m³
 SSP: **6.9** Watt/m² (γ·Q·s/w)

 d₅₀ needed: 0.31 mm

If the d₅₀ is 0.31 mm or more the channel is a Threshold channel.

THRESHOLD CHANNEL is the most likely scenario with moderate to good vegetation

Vegetation Discussion

- * There is dense vegetation in the channel
- * A vegetated channel has a resistance that depends on quality of vegetation
- * reed planting, short grass and long grasses have a range from 0.1 to 1.7 lb/sq-ft
- * A conservative value of 0.5 lb/sq-ft is used (average of low values for reed and short grass)
- * 0.4 lb/ft² is equivalent to d₅₀ = 1.2 in (30.5 mm) per Fischenich work
- * 30.5 mm is more than 98 times than needed (0.31 mm from Braided equil. eq)

Conclusion: THRESHOLD CHANNEL

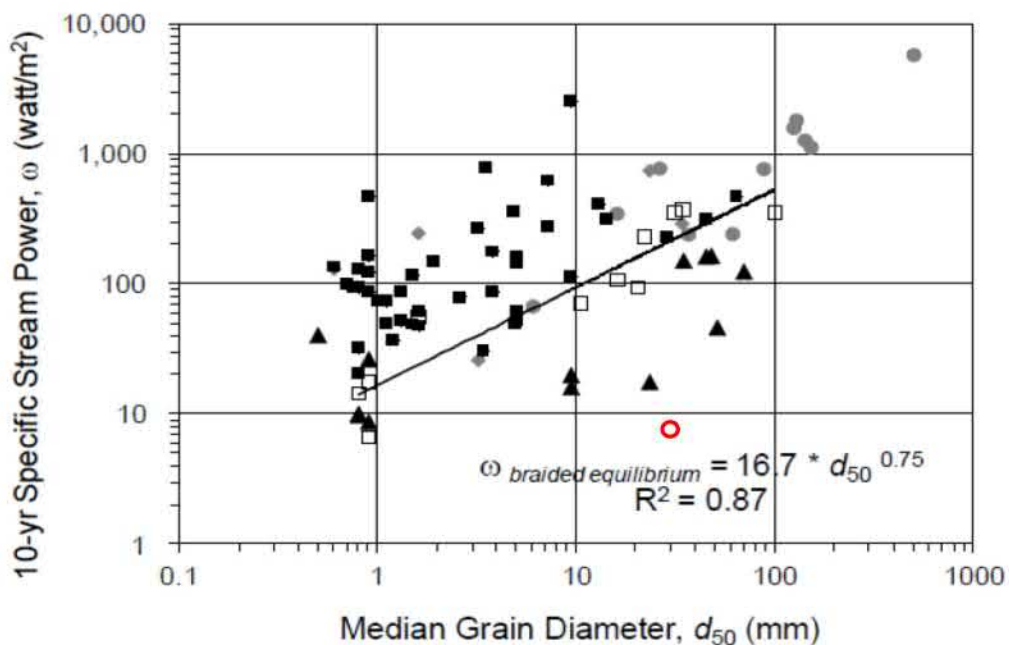

Property measurements, Guajome Creek

W average: **280 ft** (minimum)

w: 85 m

Area: 2.3 sq-miles

Prec: 14.7 inches

% imperv: 33% (from StreamStats)

AF: 1.238 (From Figure H.7-2)

Q₁₀: 368 cfs

Q₁₀: **10.43** m³/s

L: 250 ft (average)

Δz: 2 ft

s: **0.01 ft/ft** (maximum)

γ: **9810** N/m³

SSP: **12.0** Watt/m² (γ·Q·s/w)

d₅₀ needed: 0.64 mm

If the d₅₀ is 0.64 mm or more the channel is a Threshold channel.

THRESHOLD CHANNEL is the most likely scenario with moderate to good vegetation

Vegetation Discussion

- * There is dense vegetation in the channel
- * A vegetated channel has a resistance that depends on quality of vegetation
- * reed planting, short grass and long grasses have a range from 0.1 to 1.7 lb/sq-ft
- * A conservative value of 0.5 lb/sq-ft is used (average of low values for reed and short grass)
- * 0.4 lb/ft² is equivalent to d₅₀ = 1.2 in (30.5 mm) per Fischenich work
- * 30.5 mm is more than 47 times than needed (0.64 mm from Braided equil. eq)

Conclusion: THRESHOLD CHANNEL

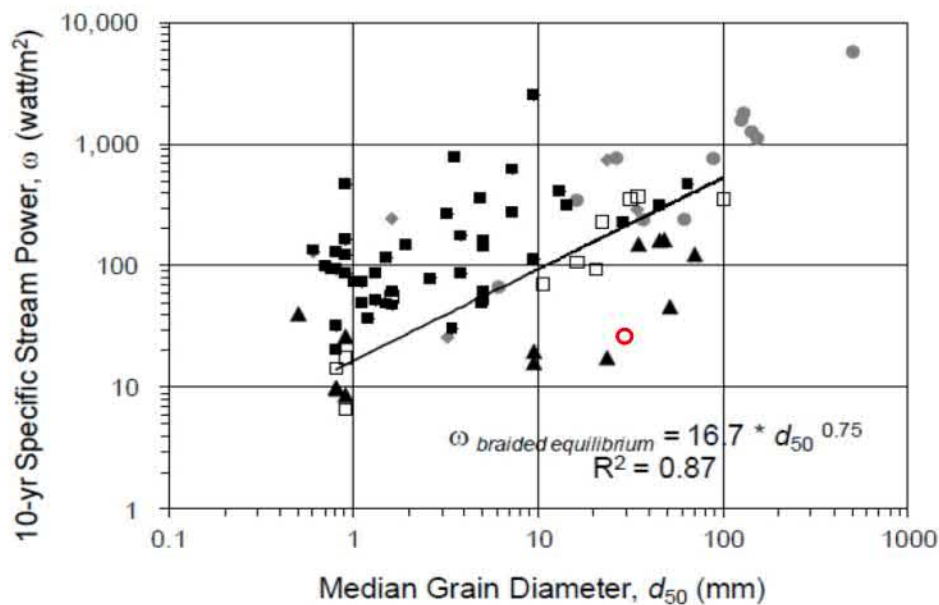

Property measurements, East Channel Creek

W average: 40 ft (from 3 measurements)
 w: 12 m

Area: 1.5 sq-miles
 Prec: 14.2 inches
 % imperv: 25% (from StreamStats)
 AF: 1.206 (From Figure H.7-2)
 Q₁₀: 241 cfs
 Q₁₀: **6.82** m³/s

L: 705 ft (average)
 Δz: 10 ft
 s: **0.014184** ft/ft
 γ: **9810** N/m³
SSP: **77.8** Watt/m² (γ·Q·s/w)

d₅₀ needed: 7.79 mm

If the d₅₀ is 7.8 mm or more the channel is a Threshold channel.

THRESHOLD CHANNEL is the most likely scenario with moderate to good vegetation

Vegetation Discussion

- * There is dense vegetation in the channel
- * A vegetated channel has a resistance that depends on quality of vegetation
- * reed planting, short grass and long grasses have a range from 0.1 to 1.7 lb/sq-ft
- * A conservative value of 0.4 lb/sq-ft is used (average of low values for reed and short grass)
- * 0.5 lb/ft² is equivalent to d₅₀ = 1.2 in (30.5 mm) per Fischenich work
- * 30.5 mm is about 3.9 times more than needed (7.8 mm from Braided equilib. Eq)

Conclusion: THRESHOLD CHANNEL

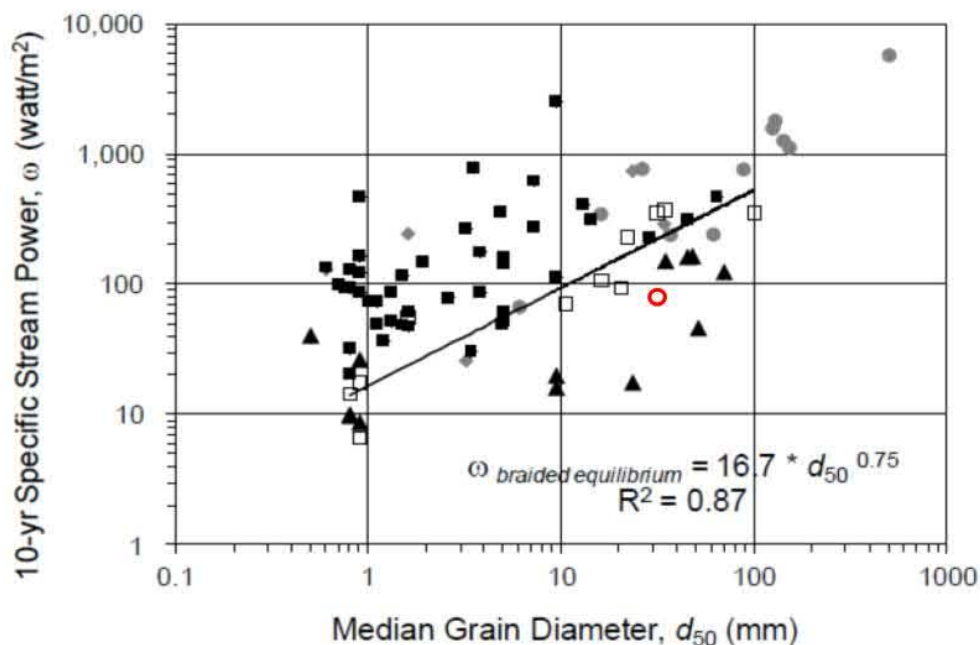

Property measurements, East Channel Creek

W average: **24 ft** (minimum)

w: 7.3 m

Area: 1.5 sq-miles

Prec: 14.2 inches

% imperv: 25.1% (from StreamStats)

AF: 1.206 (From Figure H.7-2)

Q₁₀: 241 cfs

Q₁₀: **6.82** m³/s

L: 705 ft (average)

Δz: 10 ft

s: **0.0200** ft/ft (max)

γ: **9810** N/m³

SSP: **182.9** Watt/m² (γ·Q·s/w)

d₅₀ needed: 24.3 mm

If the d₅₀ is 24.3 mm or more the channel is a Threshold channel.

THRESHOLD CHANNEL is the most likely scenario with moderate to good vegetation

Vegetation Discussion

- * There is dense vegetation in the channel
- * A vegetated channel has a resistance that depends on quality of vegetation
- * reed planting, short grass and long grasses have a range from 0.1 to 1.7 lb/sq-ft
- * A conservative value of 0.4 lb/sq-ft is used (average of low values for reed and short grass)
- * 0.5 lb/ft² is equivalent to d₅₀ = 1.2 in (30.5 mm) per Fischenich work
- * 30.5 mm is about 1.26 times more than needed (24.3 mm from Braided equilib. Eq)

Conclusion: THRESHOLD CHANNEL

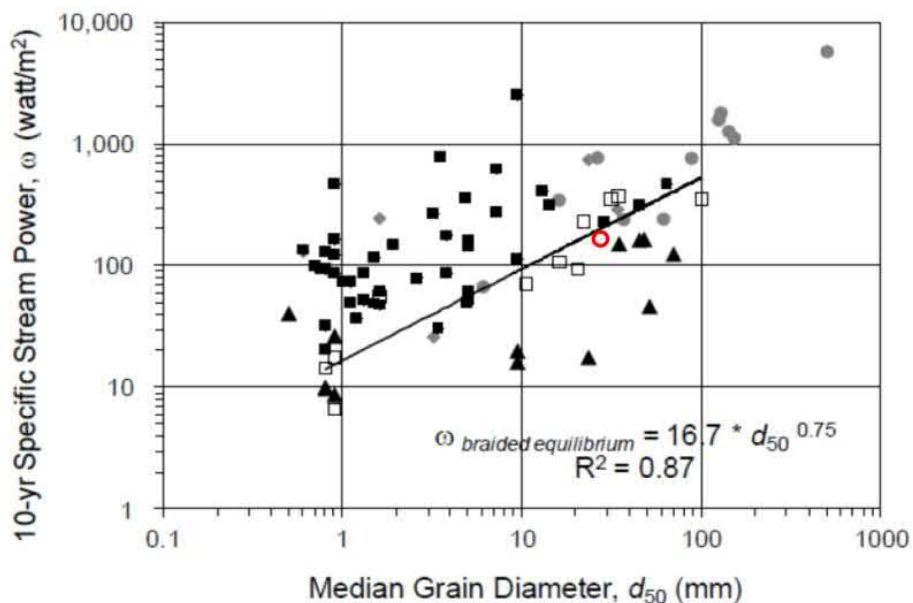

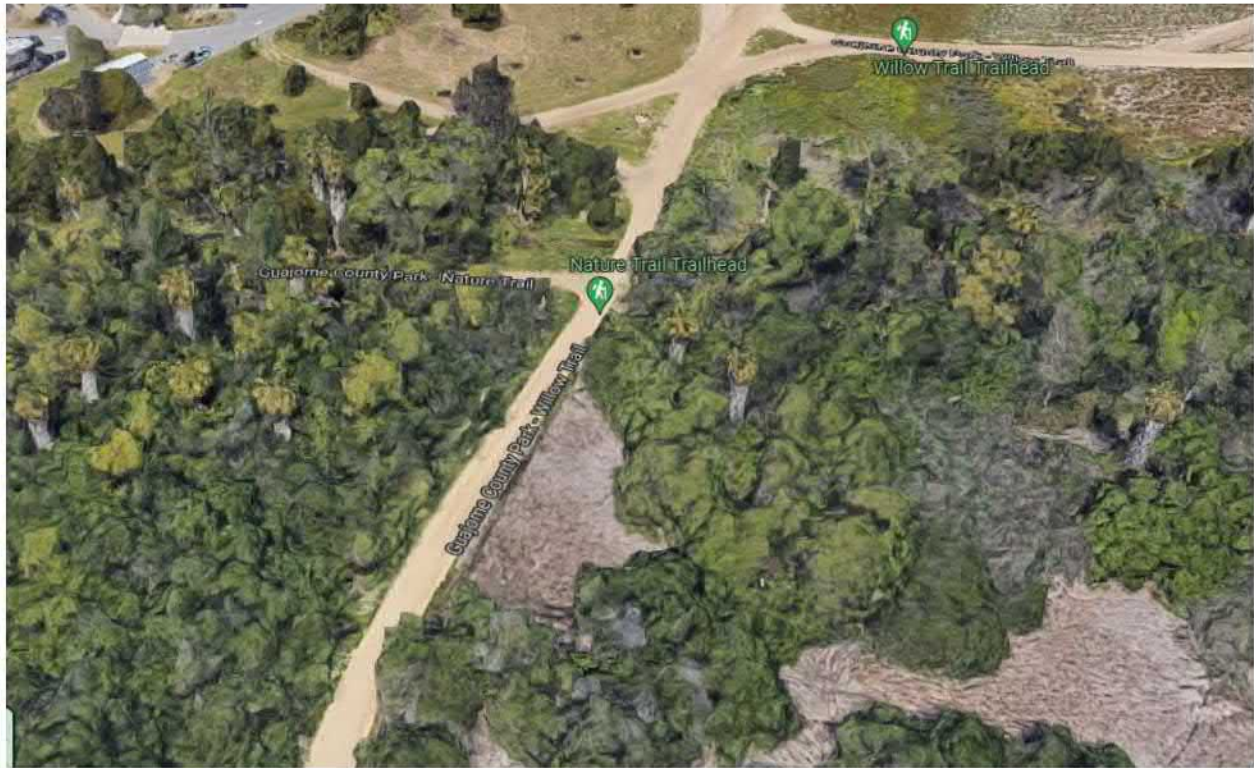

Guajome Willow Trail: Aerial View and Ground Picture. Access to the center of the creek is impossible due to dense vegetation.



Guajome Creek: End of North Santa Fe Avenue: aerial view and ground picture. Grassland typical of wet areas observed, and no access to site visit.



Guajome East Channel: Aerial View and view towards the channel. Dense vegetation observed south of the trail.

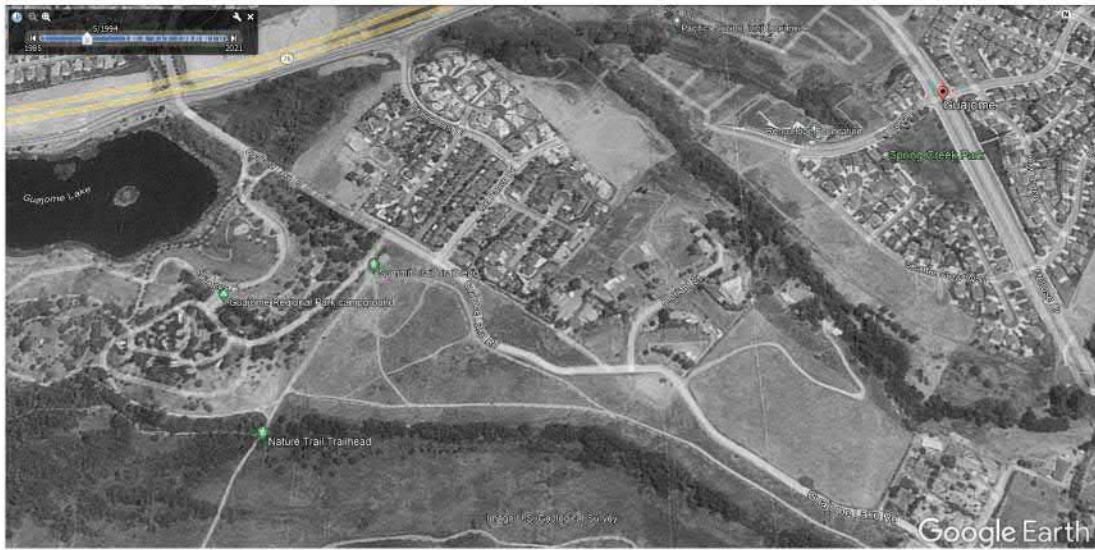

1994, 2003, 2012 Aerial Views of Guajome Creeks: Vegetation been dense for over 20 years.

Appendix 3: GLU Analysis Figures

SLOPES MAP, EXISTING CONDITIONS GUAJOME RESIDENTIAL



AREA NOT ANALYZED FOR THIS EXHIBIT

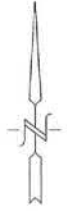
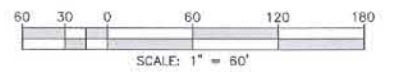

- NOTES:
1. TOPOGRAPHY FOR THIS STUDY IS FROM AERIAL PHOTOGRAMMETRY BY _____ DATE OF PHOTOGRAPHY: _____
 2. THIS STUDY WAS PREPARED BY ME OR UNDER MY DIRECTION

JONATHAN RAAB RYDEEN
RCE 64811 EXP. 6-30-2023



SLOPES LEGEND				
Number	Minimum Slope	Maximum Slope	Area (Ac)	Color
1	0.00%	10.00%	5.51	
2	10.00%	20.00%	7.86	Yellow
3	20.00%	40.00%	1.75	Orange
4	40.00%	100+	1.18	Red

NO.	REVISIONS	DESCRIPTION	DATE	APP'D

Civil Engineering • Environmental
Land Surveying
2442 Second Avenue
San Diego, CA 92101
(619)232-9200 (619)232-9210 Fax



DATE: 10-14-2021
SCALE: 1" = 100'
DRAWN: J.M.W.
CHECKED: J.P.R.

SHEET TITLE: SLOPE ANALYSIS
PROJECT: GUAJOME RESIDENTIAL
EXISTING CONDITIONS

SHEET 1
OF 1 SHEETS

2442 SECOND AVENUE, SAN DIEGO, CA 92101
 TEL: (619) 232-9200 FAX: (619) 232-9210
 WWW.RECCONSULTANTS.COM

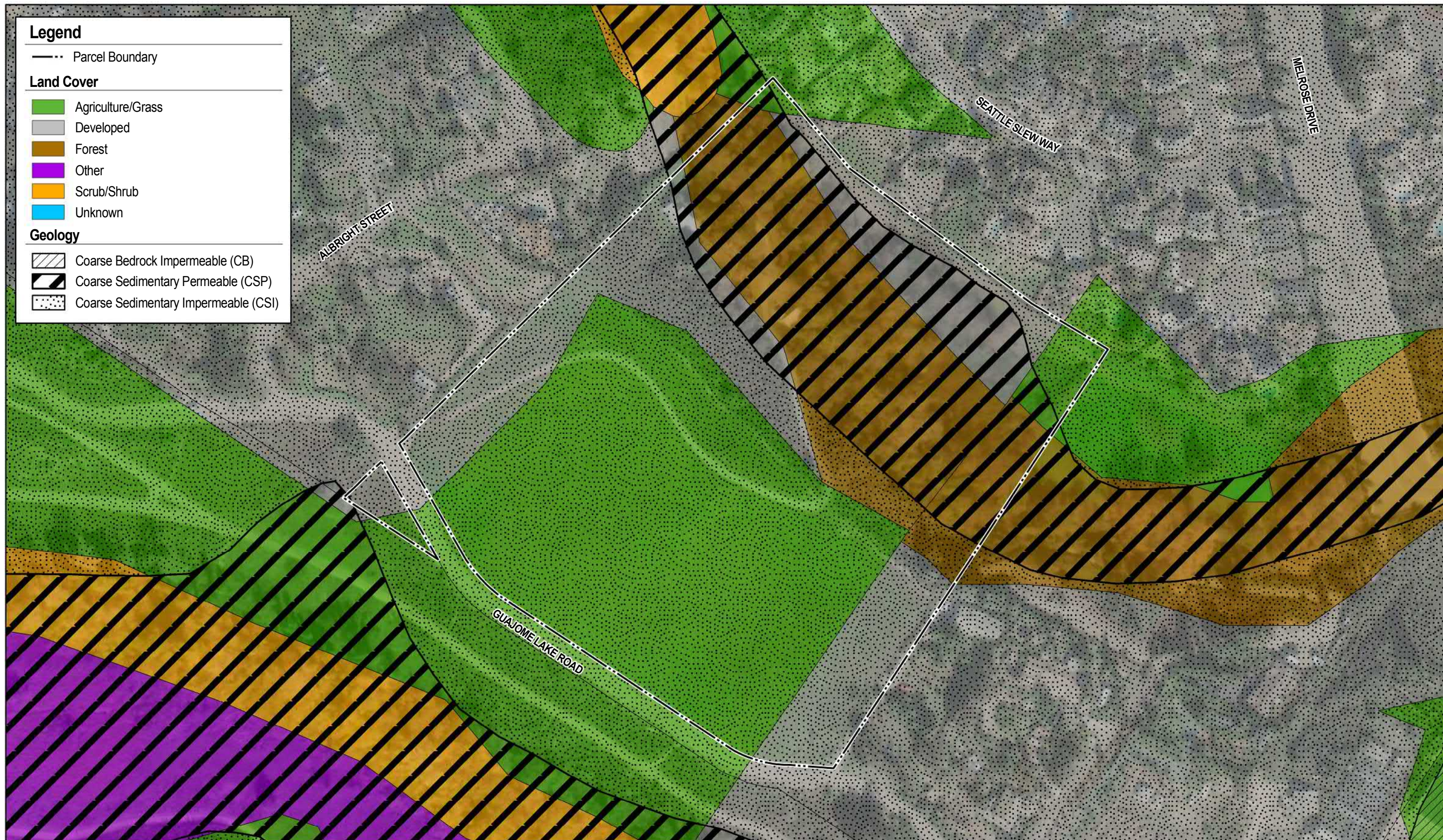

T:\Project_Data\Guajome_Residential_1729\Final_Maps\GR_LandCover_Geology_101421.mxd

Placeholder – **6.3.4 Geomorphic Assessment of Receiving Channels** (Optional)

Replace placeholder with required calculations/documentation.

Leave placeholder intact if not applicable.

Not Applicable



Placeholder - **Flow Control Facility Design and Structural BMP Drawdown Calculations**

Replace placeholder with required calculations/documentation.

See Chapter 6 and Appendix G of the BMP Design Manual

Not applicable



[TITLE]
 ;;Project Title/Notes
 3775 Rincon Guajome
 Pre-Development Condition

[OPTIONS]
 ;;Option Value
 FLOW_UNITS CFS
 INFILTRATION GREEN_AMPT
 FLOW_ROUTING KINWAVE
 LINK_OFFSETS DEPTH
 MIN_SLOPE 0
 ALLOW_PONDING NO
 SKIP_STEADY_STATE NO

START_DATE 08/28/1951
 START_TIME 05:00:00
 REPORT_START_DATE 08/28/1951
 REPORT_START_TIME 05:00:00
 END_DATE 05/23/2008
 END_TIME 23:00:00
 SWEEP_START 01/01
 SWEEP_END 12/31
 DRY_DAYS 0
 REPORT_STEP 01:00:00
 WET_STEP 00:15:00
 DRY_STEP 04:00:00
 ROUTING_STEP 0:01:00
 RULE_STEP 00:00:00

INERTIAL_DAMPING PARTIAL
 NORMAL_FLOW_LIMITED BOTH
 FORCE_MAIN_EQUATION H-W
 VARIABLE_STEP 0.75
 LENGTHENING_STEP 0
 MIN_SURFAREA 12.557
 MAX_TRIALS 8
 HEAD_TOLERANCE 0.005
 SYS_FLOW_TOL 5
 LAT_FLOW_TOL 5
 MINIMUM_STEP 0.5
 THREADS 1

[EVAPORATION]
 ;;Data Source Parameters
 ;;-----
 MONTHLY .06 .08 .11 .15 .17 .19 .19 .18 .15 .11 .08 .06
 DRY_ONLY NO

[RAINGAGES]

```

;;Name      Format      Interval SCF      Source
;;-----
Oceanside   INTENSITY 1:00      1.0      TIMESERIES Oceanside

```

```

[SUBCATCHMENTS]
;;Name      Rain Gage      Outlet      Area      %Imperv      Width      %Slope      CurbLen      SnowPack
;;-----
DMA-1       Oceanside      poc-1       4.08      0            456       11         0
DMA-2       Oceanside      poc-2       4.41      0            521       13         0

```

```

[SUBAREAS]
;;Subcatchment  N-Imperv      N-Perv      S-Imperv      S-Perv      PctZero      RouteTo      PctRouted
;;-----
DMA-1          0.012        0.08        0.05         0.1         25           OUTLET
DMA-2          0.012        0.08        0.05         0.1         25           OUTLET

```

```

[INFILTRATION]
;;Subcatchment  Param1      Param2      Param3      Param4      Param5
;;-----
DMA-1          9           0.025      0.33
DMA-2          9           0.025      0.33

```

```

[OUTFALLS]
;;Name      Elevation      Type      Stage Data      Gated      Route To
;;-----
;Basin 1
POC-1       0              FREE      NO              NO
POC-2       0              FREE      NO              NO

```

```

[TIMESERIES]
;;Name      Date      Time      Value
;;-----
Oceanside   FILE "Rain Data\oceanside.dat"

```

```

[REPORT]
;;Reporting Options
SUBCATCHMENTS ALL
NODES ALL
LINKS ALL

```

```

[TAGS]

```

```

[MAP]
DIMENSIONS 0.000 0.000 10000.000 10000.000
Units      None

```

```

[COORDINATES]
;;Node      X-Coord      Y-Coord
;;-----
POC-1       995.831      5101.735

```

POC-2 3990.385 5276.442

[VERTICES]

;;Link	X-Coord	Y-Coord
;-----		

[Polygons]

;;Subcatchment	X-Coord	Y-Coord
;-----		
DMA-1	1006.431	6977.959
DMA-2	3942.308	6862.981

[SYMBOLS]

;;Gage	X-Coord	Y-Coord
;-----		
Oceanside	2764.423	9026.442

[TITLE]
 ;;Project Title/Notes
 3775 Rincon Guajome
 Post-Project Condition

[OPTIONS]
 ;;Option Value
 FLOW_UNITS CFS
 INFILTRATION GREEN_AMPT
 FLOW_ROUTING KINWAVE
 LINK_OFFSETS DEPTH
 MIN_SLOPE 0
 ALLOW_PONDING NO
 SKIP_STEADY_STATE NO

START_DATE 08/28/1951
 START_TIME 05:00:00
 REPORT_START_DATE 08/28/1951
 REPORT_START_TIME 05:00:00
 END_DATE 05/23/2008
 END_TIME 23:00:00
 SWEEP_START 01/01
 SWEEP_END 12/31
 DRY_DAYS 0
 REPORT_STEP 01:00:00
 WET_STEP 00:15:00
 DRY_STEP 04:00:00
 ROUTING_STEP 0:01:00
 RULE_STEP 00:00:00

INERTIAL_DAMPING PARTIAL
 NORMAL_FLOW_LIMITED BOTH
 FORCE_MAIN_EQUATION H-W
 VARIABLE_STEP 0.75
 LENGTHENING_STEP 0
 MIN_SURFAREA 12.557
 MAX_TRIALS 8
 HEAD_TOLERANCE 0.005
 SYS_FLOW_TOL 5
 LAT_FLOW_TOL 5
 MINIMUM_STEP 0.5
 THREADS 1

[EVAPORATION]
 ;;Data Source Parameters
 ;;-----
 MONTHLY .06 .08 .11 .15 .17 .19 .19 .18 .15 .11 .08 .06
 DRY_ONLY NO

[RAINGAGES]

```

;;Name          Format      Interval SCF      Source
;;-----
Oceanside      INTENSITY 1:00      1.0      TIMESERIES Oceanside

```

[SUBCATCHMENTS]

```

;;Name          Rain Gage      Outlet      Area      %Imperv      Width      %Slope      CurbLen      SnowPack
;;-----
DMA-1           Oceanside      BMP-1      4.52      63           4098      7           0
SM-1(DMA-portion7/8) Oceanside      POC-1      .089      0           388      50          0
BMP-1           Oceanside      DIV        0.18469  0           107      0           0
DMA-2           Oceanside      BMP-2      2.75      72           2493      5           0
DMA-3           Oceanside      BMP-3      1.04      50           948      2           0
SM-2(DMA-6/portion7) Oceanside      POC-2      0.26      0           419      50          0
BMP-2           Oceanside      poc-2      0.10331  0           85       0           0
BMP-3           Oceanside      poc-2      0.02381  0           29       0           0

```

[SUBAREAS]

```

;;Subcatchment  N-Imperv      N-Perv      S-Imperv      S-Perv      PctZero      RouteTo      PctRouted
;;-----
DMA-1           0.012         0.06        0.05          0.1         25           OUTLET
SM-1(DMA-portion7/8) 0.012         0.06        0.05          0.1         25           OUTLET
BMP-1           0.012         0.06        0.05          0.1         25           OUTLET
DMA-2           0.012         0.06        0.05          0.1         25           OUTLET
DMA-3           0.012         0.06        0.05          0.1         25           OUTLET
SM-2(DMA-6/portion7) 0.012         0.06        0.05          0.1         25           OUTLET
BMP-2           0.012         0.06        0.05          0.1         25           OUTLET
BMP-3           0.012         0.06        0.05          0.1         25           OUTLET

```

[INFILTRATION]

```

;;Subcatchment  Param1      Param2      Param3      Param4      Param5
;;-----
DMA-1           9           0.01875    0.33
SM-1(DMA-portion7/8) 9           0.01875    0.33
BMP-1           9           0.025      0.33
DMA-2           9           0.01875    0.33
DMA-3           9           0.01875    0.33
SM-2(DMA-6/portion7) 9           0.01875    0.33
BMP-2           9           0.025      0.33
BMP-3           9           0.025      0.33

```

[LID_CONTROLS]

```

;;Name          Type/Layer      Parameters
;;-----
BMP-1           BC
BMP-1           SURFACE        6           0           0           0           5
BMP-1           SOIL           24          0.4         0.2         0.1         5           5           1.5
BMP-1           STORAGE        36          0.99        0           0           NO
BMP-1           DRAIN          0.1986      0.5         3           6           0           0
BMP-2           BC

```

BMP-2	SURFACE	12	0	0	0	5			
BMP-2	SOIL	24	0.4	0.2	0.1	5	5	1.5	
BMP-2	STORAGE	36	0.99	0	0	NO			
BMP-2	DRAIN	0.2934	0.5	3	6	0	0		
BMP-3	BC								
BMP-3	SURFACE	6.56	0	0	0	5			
BMP-3	SOIL	20	0.4	0.2	0.1	5	5	1.5	
BMP-3	STORAGE	28	0.67	0	0	NO			
BMP-3	DRAIN	0.2037	0.5	3	6	0	0		

[LID_USAGE]

;;Subcatchment	LID Process	Number	Area	Width	InitSat	FromImp	ToPerv	RptFile	DrainTo
BMP-1	BMP-1	1	8045.10	0	0	100	0	*	*
BMP-2	BMP-2	1	4500.18	0	0	100	0	*	*
BMP-3	BMP-3	1	1037.16	0	0	100	0	*	*

[OUTFALLS]

;;Name	Elevation	Type	Stage Data	Gated	Route To
POC-1	0	FREE		NO	
POC-2	0	FREE		NO	

[DIVIDERS]

;;Name	Elevation	Diverted Link	Type	Parameters
DIV	0	BYPASS	CUTOFF	0.296 0 0 0 0

[STORAGE]

;;Name	Elev.	MaxDepth	InitDepth	Shape	Curve Type/Params	SurDepth	Fevap	Psi	Ksat	IMD
STOR	0	1.5	0	TABULAR	STOR	0	0			

[CONDUITS]

;;Name	From Node	To Node	Length	Roughness	InOffset	OutOffset	InitFlow	MaxFlow
BYPASS	DIV	STOR	400	0.01	0	0	0	0
LOWFLOW	DIV	POC-1	400	0.01	0	0	0	0

[OUTLETS]

;;Name	From Node	To Node	Offset	Type	QTable/Qcoeff	Qexpon	Gated
OUTLET1	STOR	POC-1	0	TABULAR/DEPTH	OUTLET1		NO

```
[XSECTIONS]
;;Link      Shape      Geom1      Geom2      Geom3      Geom4      Barrels      Culvert
-----
BYPASS      DUMMY      0          0          0          0          1
LOWFLOW     DUMMY      0          0          0          0          1
```

```
[CURVES]
;;Name      Type      X-Value      Y-Value
-----
OUTLET1     Rating    0            0
OUTLET1     Rating    0.05         0.25
OUTLET1     Rating    0.1          0.71
OUTLET1     Rating    0.15         1.31
OUTLET1     Rating    0.2          1.87
OUTLET1     Rating    0.25         2.27
OUTLET1     Rating    0.3          2.6
OUTLET1     Rating    0.35         2.89
OUTLET1     Rating    0.4          3.15
OUTLET1     Rating    0.45         3.39
OUTLET1     Rating    0.5          3.62
OUTLET1     Rating    0.55         3.83
OUTLET1     Rating    0.6          4.03
OUTLET1     Rating    0.65         4.22
OUTLET1     Rating    0.7          4.41
OUTLET1     Rating    0.75         4.58
OUTLET1     Rating    0.8          4.75
OUTLET1     Rating    0.85         4.92
OUTLET1     Rating    0.9          5.07
OUTLET1     Rating    0.95         5.23
OUTLET1     Rating    1            5.38
OUTLET1     Rating    1.05         5.52
OUTLET1     Rating    1.1          5.66
OUTLET1     Rating    1.15         5.8
OUTLET1     Rating    1.2          7.26
OUTLET1     Rating    1.25         11.84
OUTLET1     Rating    1.3          18.15
OUTLET1     Rating    1.35         21.02
OUTLET1     Rating    1.4          21.1
OUTLET1     Rating    1.45         21.19
OUTLET1     Rating    1.5          21.27
;
STOR        Storage   0            8045
STOR        Storage   1.5          8045
```

```
[TIMESERIES]
;;Name      Date      Time      Value
-----
Oceanside   FILE "Rain Data\oceanside.dat"
```

[REPORT]
;;Reporting Options
SUBCATCHMENTS ALL
NODES ALL
LINKS ALL

[TAGS]

[MAP]
DIMENSIONS -3613.433 -2953.125 10000.000 10000.000
Units None

[COORDINATES]
;;Node X-Coord Y-Coord
;;-----
POC-1 72.115 -2391.827
POC-2 3200.000 -2306.667
DIV 107.425 2316.543
STOR -2979.058 2257.188

[VERTICES]
;;Link X-Coord Y-Coord
;;-----

[Polygons]
;;Subcatchment X-Coord Y-Coord
;;-----
DMA-1 0.000 5986.667
SM-1 (DMA-portion7/8) -3117.555 -1798.768
BMP-1 107.425 3938.926
DMA-2 3120.000 5933.333
DMA-3 5866.667 6013.333
SM-2 (DMA-6/portion7) 6800.000 -386.667
BMP-2 3093.333 2333.333
BMP-3 5653.333 2306.667

;;Storage Node X-Coord Y-Coord
;;-----
STOR -2979.058 2257.188

[SYMBOLS]
;;Gage X-Coord Y-Coord
;;-----
Oceanside 2139.423 8834.135

SWMM OUTPUT REPORT

PRE-DEVELOPMENT CONDITION

EPA STORM WATER MANAGEMENT MODEL - VERSION 5.2 (Build 5.2.4)

3775 Rincon Guajome
 Pre-Development Condition

 Analysis Options

Flow Units CFS
 Process Models:
 Rainfall/Runoff YES
 RDII NO
 Snowmelt NO
 Groundwater NO
 Flow Routing NO
 Water Quality NO
 Infiltration Method GREEN_AMPT
 Starting Date 08/28/1951 05:00:00
 Ending Date 05/23/2008 23:00:00
 Antecedent Dry Days 0.0
 Report Time Step 01:00:00
 Wet Time Step 00:15:00
 Dry Time Step 04:00:00

*****	Volume	Depth
Runoff Quantity Continuity	acre-feet	inches
*****	-----	-----
Total Precipitation	477.626	675.090
Evaporation Loss	17.055	24.106
Infiltration Loss	369.488	522.244
Surface Runoff	100.268	141.721
Final Storage	0.000	0.000
Continuity Error (%)	-1.923	

*****	Volume	Volume
Flow Routing Continuity	acre-feet	10^6 gal
*****	-----	-----
Dry Weather Inflow	0.000	0.000
Wet Weather Inflow	100.268	32.674
Groundwater Inflow	0.000	0.000
RDII Inflow	0.000	0.000
External Inflow	0.000	0.000
External Outflow	100.268	32.674
Flooding Loss	0.000	0.000
Evaporation Loss	0.000	0.000
Exfiltration Loss	0.000	0.000
Initial Stored Volume	0.000	0.000

SWMM OUTPUT REPORT

PRE-DEVELOPMENT CONDITION

Final Stored Volume 0.000 0.000
 Continuity Error (%) 0.000

 Subcatchment Runoff Summary

Subcatchment	Total Precip in	Total Runon in	Total Evap in	Total Infil in	Imperv Runoff in	Perv Runoff in	Total Runoff in	Total Runoff 10^6 gal	Peak Runoff CFS	Runoff Coeff
DMA-1	675.09	0.00	24.13	522.66	0.00	141.17	141.17	15.64	4.56	0.209
DMA-2	675.09	0.00	24.08	521.86	0.00	142.23	142.23	17.03	4.93	0.211

Analysis begun on: Wed Aug 14 08:55:12 2024
 Analysis ended on: Wed Aug 14 08:55:31 2024
 Total elapsed time: 00:00:19

SWMM OUTPUT REPORT

POST-PROJECT CONDITION

EPA STORM WATER MANAGEMENT MODEL - VERSION 5.2 (Build 5.2.4)

3775 Rincon Guajome
 Post-Project Condition
 WARNING 04: minimum elevation drop used for Conduit BYPASS
 WARNING 04: minimum elevation drop used for Conduit LOWFLOW

 Analysis Options

Flow Units CFS
 Process Models:
 Rainfall/Runoff YES
 RDII NO
 Snowmelt NO
 Groundwater NO
 Flow Routing YES
 Ponding Allowed NO
 Water Quality NO
 Infiltration Method GREEN_AMPT
 Flow Routing Method KINWAVE
 Starting Date 08/28/1951 05:00:00
 Ending Date 05/23/2008 23:00:00
 Antecedent Dry Days 0.0
 Report Time Step 01:00:00
 Wet Time Step 00:15:00
 Dry Time Step 04:00:00
 Routing Time Step 60.00 sec

*****	Volume	Depth
Runoff Quantity Continuity	acre-feet	inches
*****	-----	-----
Initial LID Storage	0.062	0.082
Total Precipitation	504.675	675.090
Evaporation Loss	79.208	105.954
Infiltration Loss	130.708	174.844
Surface Runoff	23.909	31.982
LID Drainage	279.352	373.682
Final Storage	0.097	0.130
Continuity Error (%)	-1.691	

*****	Volume	Volume
Flow Routing Continuity	acre-feet	10^6 gal
*****	-----	-----
Dry Weather Inflow	0.000	0.000
Wet Weather Inflow	303.261	98.822
Groundwater Inflow	0.000	0.000
RDII Inflow	0.000	0.000
External Inflow	0.000	0.000
External Outflow	303.257	98.821
Flooding Loss	0.000	0.000

SWMM OUTPUT REPORT

POST-PROJECT CONDITION

```
Evaporation Loss ..... 0.000      0.000
Exfiltration Loss ..... 0.000      0.000
Initial Stored Volume .... 0.000      0.000
Final Stored Volume ..... 0.000      0.000
Continuity Error (%) ..... 0.001
```

```
*****
Highest Flow Instability Indexes
*****
All links are stable.
```

```
*****
Routing Time Step Summary
*****
Minimum Time Step      : 60.00 sec
Average Time Step      : 60.00 sec
Maximum Time Step      : 60.00 sec
% of Time in Steady State : 0.00
Average Iterations per Step : 1.00
% of Steps Not Converging : 0.00
```

```
*****
Subcatchment Runoff Summary
*****
```

Subcatchment	Total Precip in	Total Runon in	Total Evap in	Total Infil in	Imperv Runoff in	Perv Runoff in	Total Runoff in	Total Runoff 10^6 gal	Peak Runoff CFS	Runoff Coeff
DMA-1	675.09	0.00	70.30	175.48	370.74	70.49	441.23	54.15	5.33	0.654
SM-1 (DMA-portion7/8)	675.09	0.00	22.06	469.69	0.00	197.69	197.69	0.48	0.10	0.293
BMP-1	675.09	10798.34	1111.13	0.00	0.00	0.00	10361.51	51.96	5.36	0.903
DMA-2	675.09	0.00	77.52	132.69	423.33	53.52	476.84	35.61	3.26	0.706
DMA-3	675.09	0.00	60.81	236.39	293.88	94.46	388.34	10.97	1.22	0.575
SM-2 (DMA-6/portion7)	675.09	0.00	22.01	472.24	0.00	193.90	193.90	1.37	0.30	0.287
BMP-2	675.09	12692.91	1137.06	0.00	0.00	0.00	12230.00	34.31	3.16	0.915
BMP-3	675.09	16962.04	1089.30	0.00	0.00	0.00	16546.72	10.70	1.25	0.938

```
*****
LID Performance Summary
*****
```

Subcatchment	LID Control	Total Inflow in	Evap Loss in	Infil Loss in	Surface Outflow in	Drain Outflow in	Initial Storage in	Final Storage in	Continuity Error %
BMP-1	BMP-1	11473.43	1111.17	0.00	559.41	9802.48	2.40	3.03	-0.00
BMP-2	BMP-2	13368.00	1137.10	0.00	311.08	11919.37	2.40	3.15	-0.00
BMP-3	BMP-3	17637.13	1089.34	0.00	3504.98	13042.41	2.00	2.84	-0.00

SWMM OUTPUT REPORT

POST-PROJECT CONDITION

 Node Depth Summary

Node	Type	Average Depth Feet	Maximum Depth Feet	Maximum HGL Feet	Time of Max Occurrence days hr:min	Reported Max Depth Feet
POC-1	OUTFALL	0.00	0.00	0.00	0 00:00	0.00
POC-2	OUTFALL	0.00	0.00	0.00	0 00:00	0.00
DIV	DIVIDER	0.00	0.00	0.00	0 00:00	0.00
STOR	STORAGE	0.00	0.60	0.60	18857 12:19	0.55

 Node Inflow Summary

Node	Type	Maximum Lateral Inflow CFS	Maximum Total Inflow CFS	Time of Max Occurrence days hr:min	Lateral Inflow Volume 10^6 gal	Total Inflow Volume 10^6 gal	Flow Balance Error Percent
POC-1	OUTFALL	0.10	4.32	18857 12:19	0.478	52.4	0.000
POC-2	OUTFALL	4.57	4.57	18857 12:01	46.4	46.4	0.000
DIV	DIVIDER	5.36	5.36	18857 12:16	52	52	0.000
STOR	STORAGE	0.00	5.07	18857 12:16	0	2.6	0.051

 Node Flooding Summary

No nodes were flooded.

 Storage Volume Summary

Storage Unit	Average Volume 1000 ft³	Avg Pcnt Full	Evap Pcnt Loss	Exfil Pcnt Loss	Maximum Volume 1000 ft³	Max Pcnt Full	Time of Max Occurrence days hr:min	Maximum Outflow CFS
STOR	0.001	0.0	0.0	0.0	4.789	39.7	18857 12:19	4.01

 Outfall Loading Summary

SWMM OUTPUT REPORT

POST-PROJECT CONDITION

Outfall Node	Flow Freq Pcmt	Avg Flow CFS	Max Flow CFS	Total Volume 10^6 gal
POC-1	4.43	0.09	4.32	52.439
POC-2	4.55	0.08	4.57	46.375
System	4.49	0.16	8.68	98.814

 Link Flow Summary

Link	Type	Maximum Flow CFS	Time of Max Occurrence days hr:min	Maximum Veloc ft/sec	Max/ Full Flow	Max/ Full Depth
BYPASS	DUMMY	5.07	18857 12:16			
LOWFLOW	DUMMY	0.30	15835 15:29			
OUTLET1	DUMMY	4.01	18857 12:19			

 Conduit Surcharge Summary

No conduits were surcharged.

Analysis begun on: Wed Aug 14 09:11:30 2024
 Analysis ended on: Wed Aug 14 09:12:05 2024
 Total elapsed time: 00:00:35

POC-1

SWMM MODEL SCHEMATICS

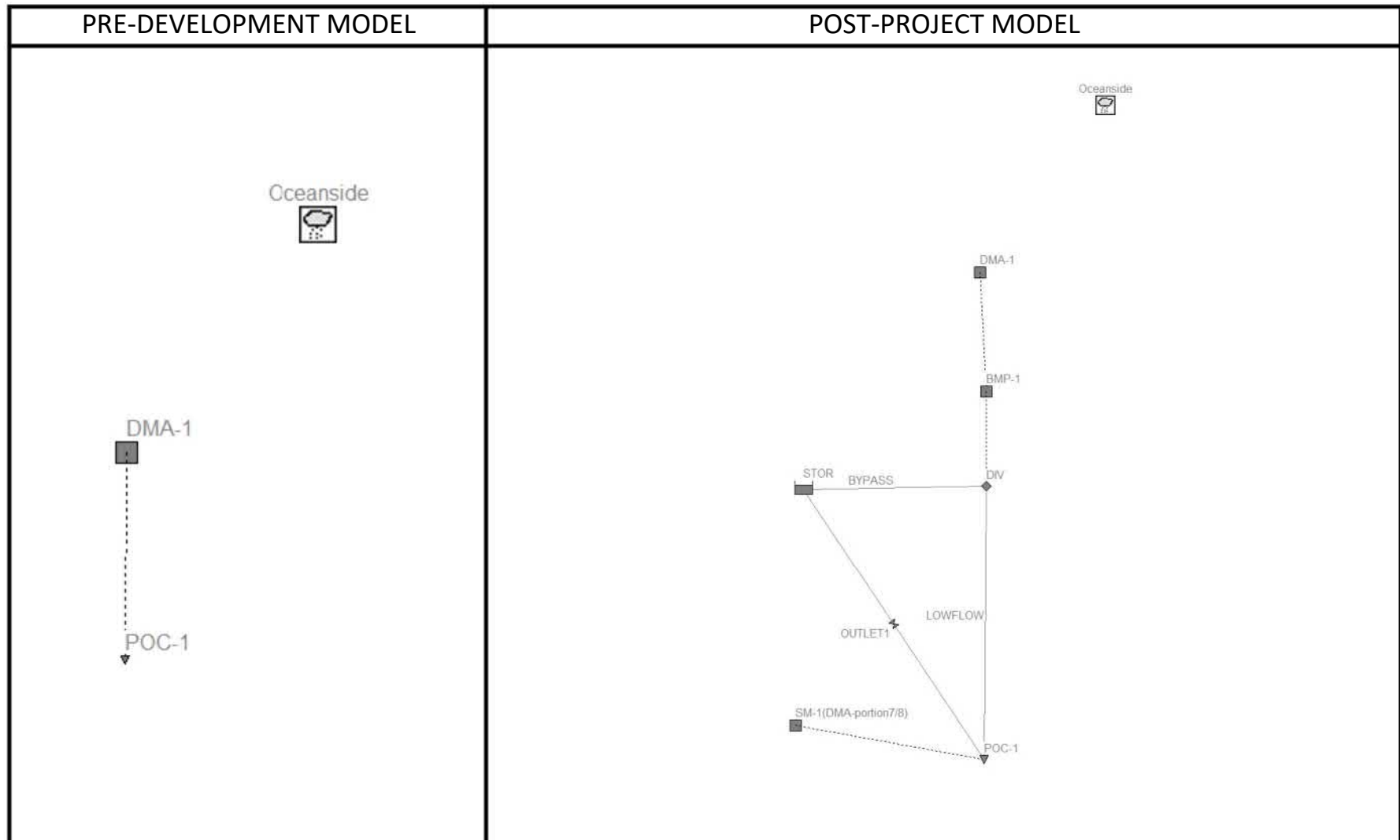

POC-1

PRE-DEVELOPMENT										
DMA	N-perv	Area (ac)	Width (Area/Flow Length) (ft)	% Slope	% Impervious	% C Soils	% D Soils	Weighted Infiltration (in/hr):	Weighted Suction Head (in):	Weighted Initial Deficit:
DMA-1	0.08	4.08	456	11.0%	0%	0%	100%	0.025	9.000	0.330

Total: 4.08

POST-PROJECT										
DMA	N-perv	Area (ac)	Width (Area/Flow Length) (ft)	% Slope	% Impervious	% C Soils	% D Soils	Weighted Infiltration (in/hr):	Weighted Suction Head (in):	Weighted Initial Deficit:
DMA-1	0.06	4.52	4098	7.0%	63%	0%	100%	0.01875	9.000	0.330
SM-1 (DMA-portion7/8)	0.06	0.089	388	50.0%	0%	0%	100%	0.01875	9.000	0.330
BMP-1	0.06	0.18469	107	0.0%	0%	0%	100%	0.025	9.000	0.330

Total: 4.79

Infiltration:		
D	0.025	in/hr

Suction Head:		
D	9	in

Initial Deficit:		
D	0.33	

POC-1

Peak Flow Frequency Summary

Return Period	Pre-project Qpeak (cfs)	Post-project - Mitigated Q (cfs)
LF = 0.1xQ2	0.215	0.084
2-year	2.150	0.842
5-year	2.737	1.810
10-year	3.441	2.740

POC-1 Peak Flow Frequency Curves

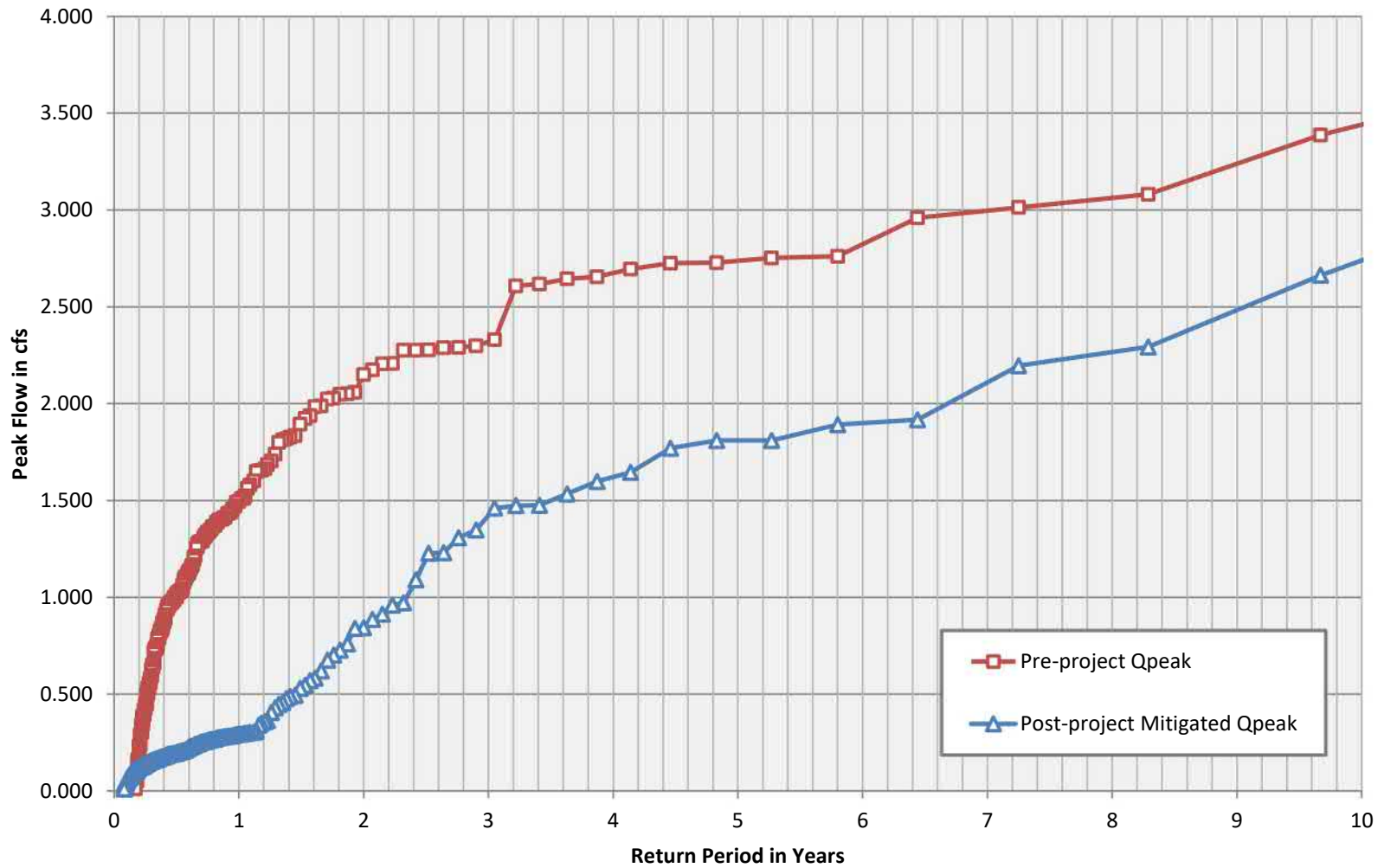

Low-flow Threshold: 10%
0.1xQ2 (Pre): 0.215 cfs
Q10 (Pre): 3.441 cfs
Ordinate #: 100
Incremental Q (Pre): 0.03226 cfs
Total Hourly Data: 497370 hours

POC-1

The proposed BMP: **PASSED**

Interval	Pre-project Flow (cfs)	Pre-project Hours	Pre-project % Time Exceeding	Post-project Hours	Post-project % Time Exceeding	Percentage	Pass/Fail
0	0.215	877	1.76E-03	861	1.73E-03	98%	Pass
1	0.247	794	1.60E-03	613	1.23E-03	77%	Pass
2	0.280	720	1.45E-03	409	8.22E-04	57%	Pass
3	0.312	657	1.32E-03	168	3.38E-04	26%	Pass
4	0.344	611	1.23E-03	144	2.90E-04	24%	Pass
5	0.376	571	1.15E-03	129	2.59E-04	23%	Pass
6	0.409	539	1.08E-03	116	2.33E-04	22%	Pass
7	0.441	501	1.01E-03	104	2.09E-04	21%	Pass
8	0.473	481	9.67E-04	95	1.91E-04	20%	Pass
9	0.505	446	8.97E-04	86	1.73E-04	19%	Pass
10	0.538	422	8.48E-04	79	1.59E-04	19%	Pass
11	0.570	388	7.80E-04	75	1.51E-04	19%	Pass
12	0.602	371	7.46E-04	71	1.43E-04	19%	Pass
13	0.634	344	6.92E-04	69	1.39E-04	20%	Pass
14	0.667	320	6.43E-04	68	1.37E-04	21%	Pass
15	0.699	285	5.73E-04	65	1.31E-04	23%	Pass
16	0.731	271	5.45E-04	60	1.21E-04	22%	Pass
17	0.763	260	5.23E-04	58	1.17E-04	22%	Pass
18	0.796	248	4.99E-04	57	1.15E-04	23%	Pass
19	0.828	233	4.68E-04	57	1.15E-04	24%	Pass
20	0.860	220	4.42E-04	52	1.05E-04	24%	Pass
21	0.892	206	4.14E-04	49	9.85E-05	24%	Pass
22	0.925	201	4.04E-04	44	8.85E-05	22%	Pass
23	0.957	188	3.78E-04	41	8.24E-05	22%	Pass
24	0.989	171	3.44E-04	38	7.64E-05	22%	Pass
25	1.021	159	3.20E-04	37	7.44E-05	23%	Pass
26	1.054	142	2.86E-04	36	7.24E-05	25%	Pass
27	1.086	134	2.69E-04	35	7.04E-05	26%	Pass
28	1.118	127	2.55E-04	32	6.43E-05	25%	Pass
29	1.150	121	2.43E-04	31	6.23E-05	26%	Pass
30	1.183	116	2.33E-04	31	6.23E-05	27%	Pass
31	1.215	113	2.27E-04	29	5.83E-05	26%	Pass
32	1.247	111	2.23E-04	27	5.43E-05	24%	Pass
33	1.279	108	2.17E-04	27	5.43E-05	25%	Pass
34	1.312	100	2.01E-04	25	5.03E-05	25%	Pass
35	1.344	94	1.89E-04	24	4.83E-05	26%	Pass
36	1.376	88	1.77E-04	23	4.62E-05	26%	Pass
37	1.408	80	1.61E-04	23	4.62E-05	29%	Pass
38	1.441	74	1.49E-04	23	4.62E-05	31%	Pass
39	1.473	68	1.37E-04	21	4.22E-05	31%	Pass
40	1.505	66	1.33E-04	20	4.02E-05	30%	Pass
41	1.537	63	1.27E-04	18	3.62E-05	29%	Pass
42	1.570	61	1.23E-04	18	3.62E-05	30%	Pass
43	1.602	58	1.17E-04	17	3.42E-05	29%	Pass
44	1.634	57	1.15E-04	17	3.42E-05	30%	Pass
45	1.666	53	1.07E-04	16	3.22E-05	30%	Pass
46	1.699	51	1.03E-04	16	3.22E-05	31%	Pass
47	1.731	49	9.85E-05	16	3.22E-05	33%	Pass
48	1.763	48	9.65E-05	16	3.22E-05	33%	Pass
49	1.796	48	9.65E-05	15	3.02E-05	31%	Pass
50	1.828	44	8.85E-05	12	2.41E-05	27%	Pass
51	1.860	43	8.65E-05	12	2.41E-05	28%	Pass
52	1.892	43	8.65E-05	11	2.21E-05	26%	Pass
53	1.925	41	8.24E-05	10	2.01E-05	24%	Pass
54	1.957	40	8.04E-05	10	2.01E-05	25%	Pass

Interval	Pre-project Flow (cfs)	Pre-project Hours	Pre-project % Time Exceeding	Post-project Hours	Post-project % Time Exceeding	Percentage	Pass/Fail
55	1.989	38	7.64E-05	10	2.01E-05	26%	Pass
56	2.021	38	7.64E-05	10	2.01E-05	26%	Pass
57	2.054	34	6.84E-05	10	2.01E-05	29%	Pass
58	2.086	33	6.63E-05	10	2.01E-05	30%	Pass
59	2.118	33	6.63E-05	10	2.01E-05	30%	Pass
60	2.150	32	6.43E-05	10	2.01E-05	31%	Pass
61	2.183	31	6.23E-05	10	2.01E-05	32%	Pass
62	2.215	29	5.83E-05	9	1.81E-05	31%	Pass
63	2.247	29	5.83E-05	9	1.81E-05	31%	Pass
64	2.279	26	5.23E-05	9	1.81E-05	35%	Pass
65	2.312	22	4.42E-05	8	1.61E-05	36%	Pass
66	2.344	21	4.22E-05	8	1.61E-05	38%	Pass
67	2.376	21	4.22E-05	8	1.61E-05	38%	Pass
68	2.408	21	4.22E-05	8	1.61E-05	38%	Pass
69	2.441	21	4.22E-05	8	1.61E-05	38%	Pass
70	2.473	21	4.22E-05	8	1.61E-05	38%	Pass
71	2.505	21	4.22E-05	8	1.61E-05	38%	Pass
72	2.537	20	4.02E-05	8	1.61E-05	40%	Pass
73	2.570	20	4.02E-05	8	1.61E-05	40%	Pass
74	2.602	20	4.02E-05	8	1.61E-05	40%	Pass
75	2.634	18	3.62E-05	8	1.61E-05	44%	Pass
76	2.666	15	3.02E-05	7	1.41E-05	47%	Pass
77	2.699	14	2.81E-05	7	1.41E-05	50%	Pass
78	2.731	11	2.21E-05	7	1.41E-05	64%	Pass
79	2.763	9	1.81E-05	6	1.21E-05	67%	Pass
80	2.795	9	1.81E-05	6	1.21E-05	67%	Pass
81	2.828	9	1.81E-05	6	1.21E-05	67%	Pass
82	2.860	9	1.81E-05	6	1.21E-05	67%	Pass
83	2.892	9	1.81E-05	6	1.21E-05	67%	Pass
84	2.924	9	1.81E-05	6	1.21E-05	67%	Pass
85	2.957	9	1.81E-05	6	1.21E-05	67%	Pass
86	2.989	8	1.61E-05	6	1.21E-05	75%	Pass
87	3.021	7	1.41E-05	6	1.21E-05	86%	Pass
88	3.053	7	1.41E-05	6	1.21E-05	86%	Pass
89	3.086	6	1.21E-05	6	1.21E-05	100%	Pass
90	3.118	6	1.21E-05	5	1.01E-05	83%	Pass
91	3.150	6	1.21E-05	5	1.01E-05	83%	Pass
92	3.182	6	1.21E-05	4	8.04E-06	67%	Pass
93	3.215	6	1.21E-05	4	8.04E-06	67%	Pass
94	3.247	6	1.21E-05	4	8.04E-06	67%	Pass
95	3.279	6	1.21E-05	4	8.04E-06	67%	Pass
96	3.311	6	1.21E-05	4	8.04E-06	67%	Pass
97	3.344	6	1.21E-05	4	8.04E-06	67%	Pass
98	3.376	6	1.21E-05	4	8.04E-06	67%	Pass
99	3.408	5	1.01E-05	4	8.04E-06	80%	Pass
100	3.441	5	1.01E-05	4	8.04E-06	80%	Pass

POC-1

Flow Duration Curve

[Pre vs. Post (Mitigated)]

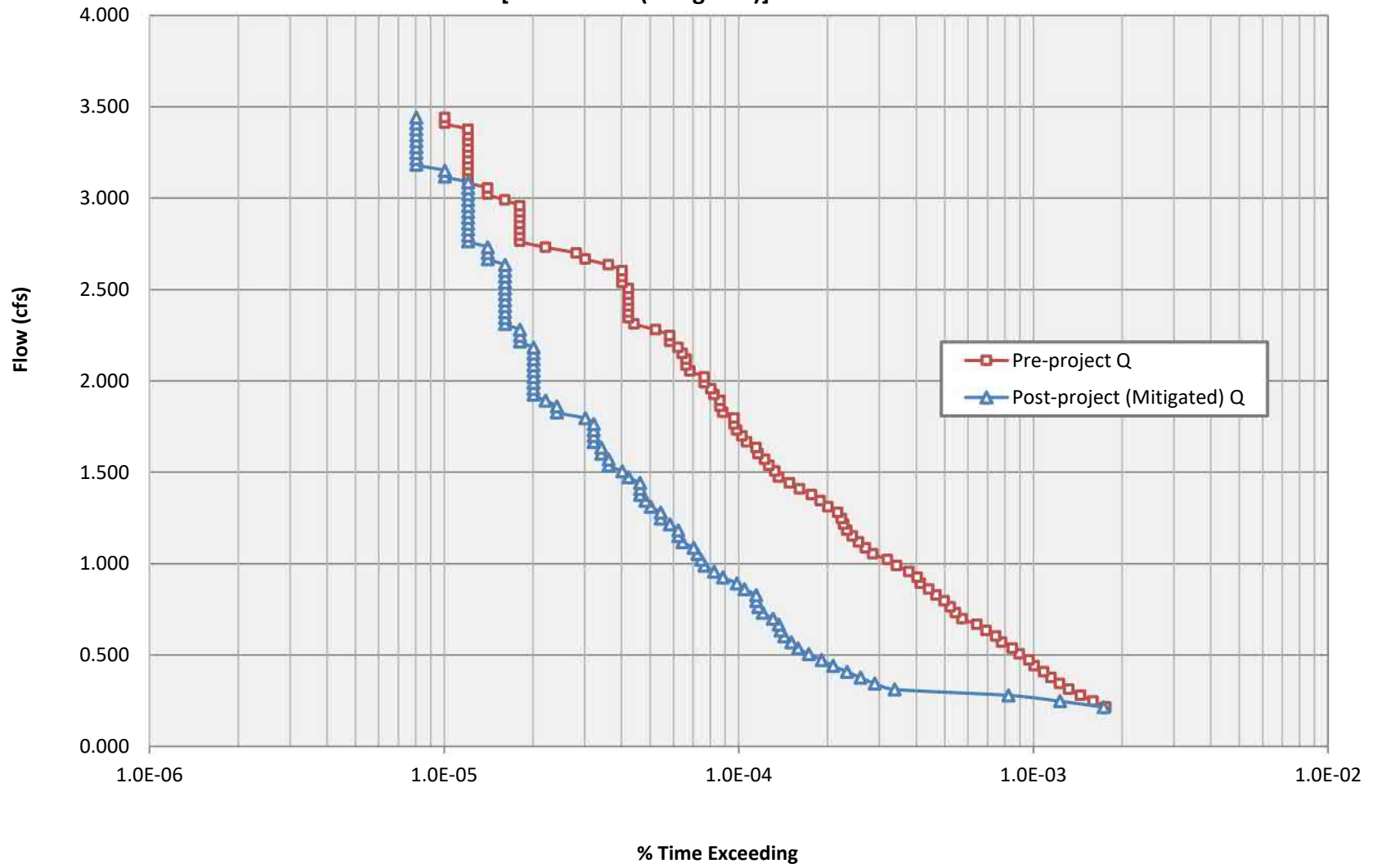

POC-1

**SWMM Model Flow Coefficient Calculation and
Effective Ponding Depth Calculation**

BMP-1

PARAMETER	ABBREV.	Bio-Retention Cell LID BMP	
Ponding Depth	PD	6.0	in
Bioretention Soil Layer	S	24	in
Permavoid Layer	G	36	in
TOTAL		5.5	ft
		66	in
Orifice Coefficient	c_g	0.6	--
Low Flow Orifice Diameter	D	2.2	in
Drain exponent	n	0.5	--
Flow Rate (volumetric)	Q	0.296	cfs
Ponding Depth Surface Area	A_{PD}	8045	ft ²
Bioretention Surface Area	A_S, A_G	8045	ft ²
	A_S, A_G	0.1847	ac
Porosity of Bioretention Soil	n	0.40	-
Flow Rate (per unit area)	q	3.968	in/hr
Effective Ponding Depth	PD_{eff}	6.00	in
Flow Coefficient	C	0.1986	--

Summary for Pond 4P: STOR

Volume	Invert	Avail.Storage	Storage Description
#1	100.50'	12,068 cf	Biofiltration Basin (Conic) Listed below (Recalc)

Elevation (feet)	Surf.Area (sq-ft)	Voids (%)	Inc.Store (cubic-feet)	Cum.Store (cubic-feet)	Wet.Area (sq-ft)
100.50	8,045	0.0	0	0	8,045
102.00	8,045	100.0	12,068	12,068	8,522

Device	Routing	Invert	Outlet Devices
#1	Primary	95.00'	18.00" Round Outlet L= 10.0' RCP, square edge headwall, Ke= 0.500 Inlet / Outlet Invert= 95.00' / 94.90' S= 0.0100 '/' Cc= 0.900 n= 0.013, Flow Area= 1.77 sf
#2	Device 1	100.50'	21.00" W x 2.00" H Vert. Orifice X 4.00 C= 0.600 Limited to weir flow at low heads
#3	Device 1	101.67'	36.00" x 36.00" Horiz. Grate C= 0.600 in 36.00" x 36.00" Grate (100% open area) Limited to weir flow at low heads
#4	Device 1	101.67'	36.00" x 36.00" Horiz. Grate C= 0.600 in 36.00" x 36.00" Grate (100% open area) Limited to weir flow at low heads
#5	Device 1	101.67'	36.00" x 36.00" Horiz. Grate C= 0.600 in 36.00" x 36.00" Grate (100% open area) Limited to weir flow at low heads
#6	Device 1	101.67'	36.00" x 36.00" Horiz. Grate C= 0.600 in 36.00" x 36.00" Grate (100% open area) Limited to weir flow at low heads
#7	Device 1	101.67'	36.00" x 36.00" Horiz. Grate C= 0.600 in 36.00" x 36.00" Grate (100% open area) Limited to weir flow at low heads
#8	Device 1	101.67'	36.00" x 36.00" Horiz. Grate C= 0.600 in 36.00" x 36.00" Grate (100% open area) Limited to weir flow at low heads
#9	Device 1	101.67'	18.00" x 18.00" Horiz. Grate C= 0.600 in 18.00" x 18.00" Grate (100% open area) Limited to weir flow at low heads

Stage-Discharge for Pond 4P: STOR

Elevation (feet)	Primary (cfs)
100.50	0.00
100.55	0.25
100.60	0.71
100.65	1.31
100.70	1.87
100.75	2.27
100.80	2.60
100.85	2.89
100.90	3.15
100.95	3.39
101.00	3.62
101.05	3.83
101.10	4.03
101.15	4.22
101.20	4.41
101.25	4.58
101.30	4.75
101.35	4.92
101.40	5.07
101.45	5.23
101.50	5.38
101.55	5.52
101.60	5.66
101.65	5.80
101.70	7.26
101.75	11.84
101.80	18.15
101.85	21.02
101.90	21.10
101.95	21.19
102.00	21.27

Drawdown Calculation for BMP-1

Project Name

Rincon Guajome

Project No

3775

Surface Drawdown Time:	3.9	hr
Surface Area	8045	sq ft
Underdrain Orifice Diameter: in	2.2	in
C:	0.6	
Surface Ponding (to invert of lowest surface discharge opening in outlet structure):	0.5	ft
Amended Soil Depth:	2	ft
Permavoid Depth:	2.75	ft
Orifice Q =	0.289	cfs
Effective Depth	42.15	in
Infiltration controlled by soil	5.000	in/hr
Infiltration controlled by orifice	1.549	in/hr

POC-2

SWMM MODEL SCHEMATICS

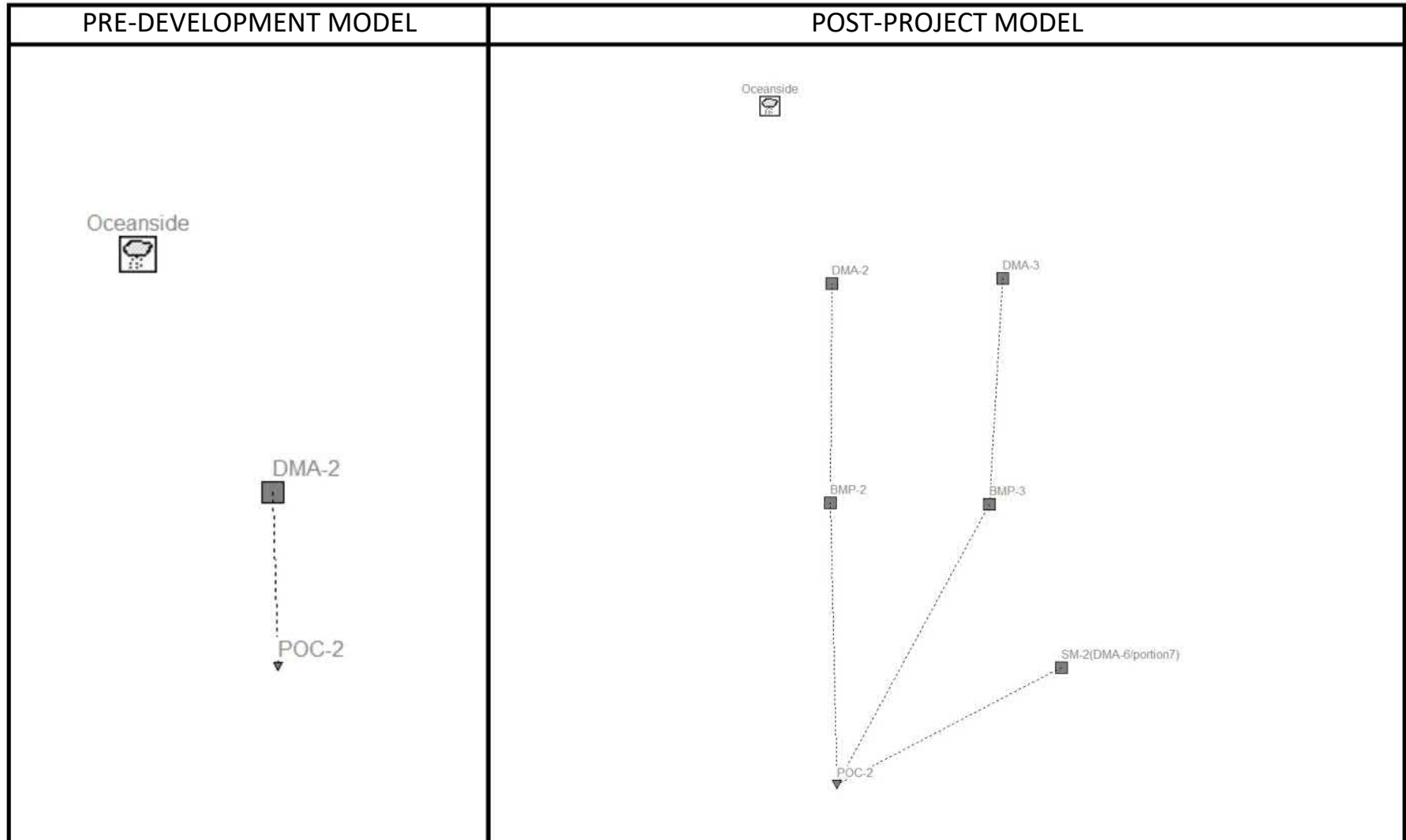

POC-2

PRE-DEVELOPMENT										
DMA	N-perv	Area (ac)	Width (Area/Flow Length) (ft)	% Slope	% Impervious	% C Soils	% D Soils	Weighted Infiltration (in/hr):	Weighted Suction Head (in):	Weighted Initial Deficit:
DMA-2	0.08	4.41	521	13.0%	0%	0%	100%	0.025	9.000	0.330

Total: 4.41

POST-PROJECT										
DMA	N-perv	Area (ac)	Width (Area/Flow Length) (ft)	% Slope	% Impervious	% C Soils	% D Soils	Weighted Infiltration (in/hr):	Weighted Suction Head (in):	Weighted Initial Deficit:
DMA-2	0.06	2.75	2493	5.0%	72%	0%	100%	0.01875	9.000	0.330
DMA-3	0.06	1.04	948	2.0%	50%	0%	100%	0.01875	9.000	0.330
SM-2 (DMA-6/portion7)	0.06	0.260	419	50.0%	0%	0%	100%	0.01875	9.000	0.330
BMP-2	0.06	0.10331	85	0.0%	0%	0%	100%	0.025	9.000	0.330
BMP-3	0.06	0.02381	29	0.0%	0%	0%	100%	0.025	9.000	0.330

Total: 4.18

Infiltration:		
D	0.025	in/hr

Suction Head:		
D	9	in

Initial Deficit:		
D	0.33	

POC-2

Peak Flow Frequency Summary

Return Period	Pre-project Qpeak (cfs)	Post-project - Mitigated Q (cfs)
LF = 0.1xQ2	0.235	0.087
2-year	2.348	0.866
5-year	2.977	1.629
10-year	3.753	2.594

POC-2 Peak Flow Frequency Curves

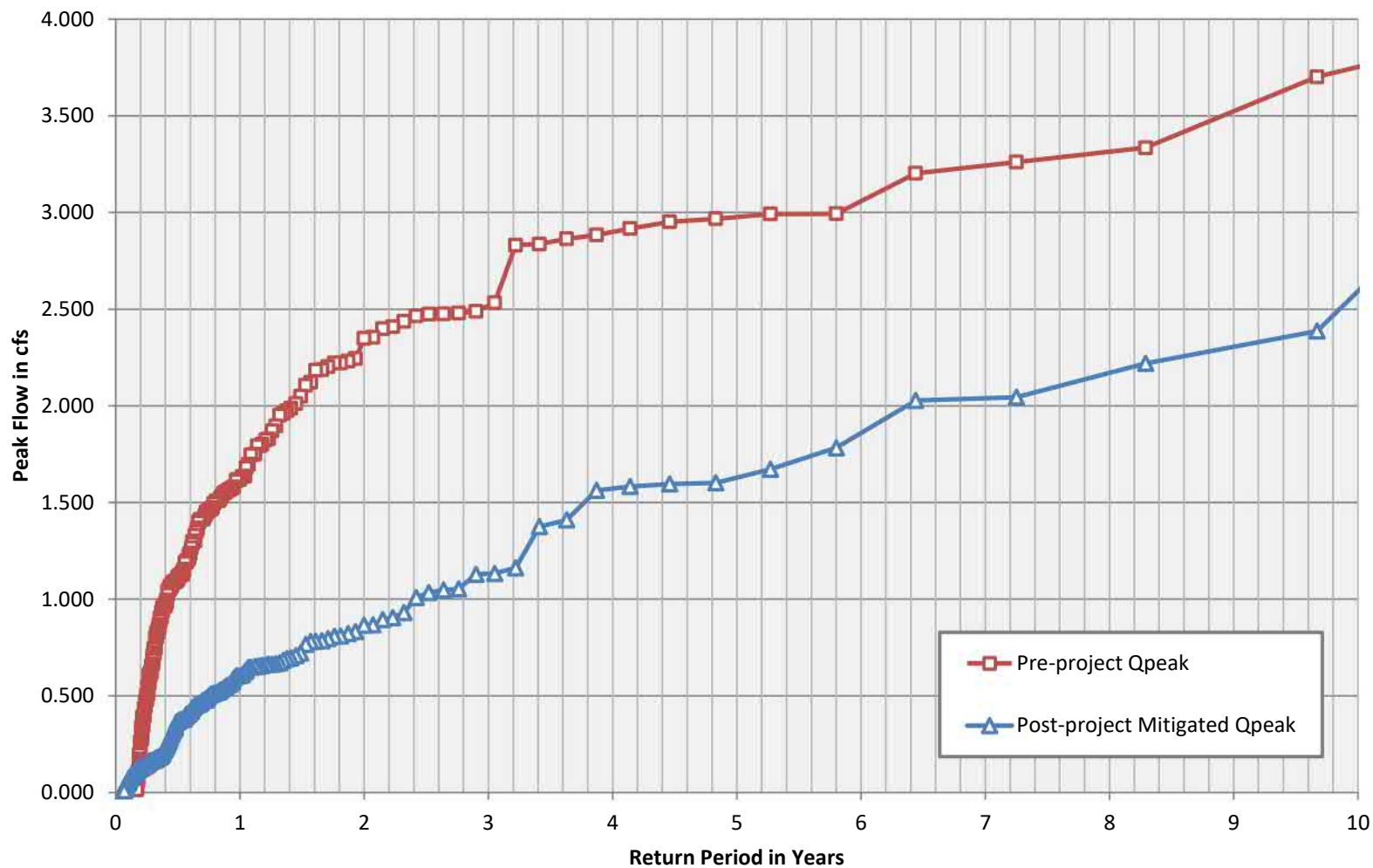

Low-flow Threshold: 10%
 0.1xQ2 (Pre): 0.235 cfs
 Q10 (Pre): 3.753 cfs
 Ordinate #: 100
 Incremental Q (Pre): 0.03518 cfs
 Total Hourly Data: 497370 hours

POC-2

The proposed BMP: **PASSED**

Interval	Pre-project Flow (cfs)	Pre-project Hours	Pre-project % Time Exceeding	Post-project Hours	Post-project % Time Exceeding	Percentage	Pass/Fail
0	0.235	876	1.76E-03	849	1.71E-03	97%	Pass
1	0.270	788	1.58E-03	566	1.14E-03	72%	Pass
2	0.305	711	1.43E-03	351	7.06E-04	49%	Pass
3	0.340	658	1.32E-03	293	5.89E-04	45%	Pass
4	0.376	621	1.25E-03	242	4.87E-04	39%	Pass
5	0.411	577	1.16E-03	199	4.00E-04	34%	Pass
6	0.446	550	1.11E-03	181	3.64E-04	33%	Pass
7	0.481	508	1.02E-03	152	3.06E-04	30%	Pass
8	0.516	484	9.73E-04	130	2.61E-04	27%	Pass
9	0.551	451	9.07E-04	111	2.23E-04	25%	Pass
10	0.587	424	8.52E-04	101	2.03E-04	24%	Pass
11	0.622	397	7.98E-04	89	1.79E-04	22%	Pass
12	0.657	371	7.46E-04	76	1.53E-04	20%	Pass
13	0.692	350	7.04E-04	65	1.31E-04	19%	Pass
14	0.727	321	6.45E-04	61	1.23E-04	19%	Pass
15	0.763	290	5.83E-04	55	1.11E-04	19%	Pass
16	0.798	275	5.53E-04	45	9.05E-05	16%	Pass
17	0.833	264	5.31E-04	41	8.24E-05	16%	Pass
18	0.868	251	5.05E-04	37	7.44E-05	15%	Pass
19	0.903	239	4.81E-04	35	7.04E-05	15%	Pass
20	0.938	225	4.52E-04	31	6.23E-05	14%	Pass
21	0.974	211	4.24E-04	30	6.03E-05	14%	Pass
22	1.009	199	4.00E-04	29	5.83E-05	15%	Pass
23	1.044	191	3.84E-04	28	5.63E-05	15%	Pass
24	1.079	176	3.54E-04	26	5.23E-05	15%	Pass
25	1.114	158	3.18E-04	26	5.23E-05	16%	Pass
26	1.150	143	2.88E-04	24	4.83E-05	17%	Pass
27	1.185	134	2.69E-04	23	4.62E-05	17%	Pass
28	1.220	126	2.53E-04	23	4.62E-05	18%	Pass
29	1.255	123	2.47E-04	22	4.42E-05	18%	Pass
30	1.290	118	2.37E-04	21	4.22E-05	18%	Pass
31	1.325	115	2.31E-04	21	4.22E-05	18%	Pass
32	1.361	111	2.23E-04	21	4.22E-05	19%	Pass
33	1.396	110	2.21E-04	20	4.02E-05	18%	Pass
34	1.431	103	2.07E-04	19	3.82E-05	18%	Pass
35	1.466	92	1.85E-04	19	3.82E-05	21%	Pass
36	1.501	89	1.79E-04	19	3.82E-05	21%	Pass
37	1.537	82	1.65E-04	19	3.82E-05	23%	Pass
38	1.572	76	1.53E-04	18	3.62E-05	24%	Pass
39	1.607	69	1.39E-04	13	2.61E-05	19%	Pass
40	1.642	64	1.29E-04	13	2.61E-05	20%	Pass
41	1.677	63	1.27E-04	12	2.41E-05	19%	Pass
42	1.712	61	1.23E-04	12	2.41E-05	20%	Pass
43	1.748	60	1.21E-04	12	2.41E-05	20%	Pass
44	1.783	57	1.15E-04	12	2.41E-05	21%	Pass
45	1.818	54	1.09E-04	11	2.21E-05	20%	Pass
46	1.853	50	1.01E-04	11	2.21E-05	22%	Pass
47	1.888	49	9.85E-05	11	2.21E-05	22%	Pass
48	1.924	48	9.65E-05	11	2.21E-05	23%	Pass
49	1.959	47	9.45E-05	11	2.21E-05	23%	Pass
50	1.994	44	8.85E-05	11	2.21E-05	25%	Pass
51	2.029	43	8.65E-05	10	2.01E-05	23%	Pass
52	2.064	42	8.44E-05	9	1.81E-05	21%	Pass
53	2.099	42	8.44E-05	9	1.81E-05	21%	Pass
54	2.135	40	8.04E-05	9	1.81E-05	23%	Pass

Interval	Pre-project Flow (cfs)	Pre-project Hours	Pre-project % Time Exceeding	Post-project Hours	Post-project % Time Exceeding	Percentage	Pass/Fail
55	2.170	40	8.04E-05	9	1.81E-05	23%	Pass
56	2.205	37	7.44E-05	9	1.81E-05	24%	Pass
57	2.240	34	6.84E-05	8	1.61E-05	24%	Pass
58	2.275	33	6.63E-05	8	1.61E-05	24%	Pass
59	2.311	33	6.63E-05	8	1.61E-05	24%	Pass
60	2.346	33	6.63E-05	7	1.41E-05	21%	Pass
61	2.381	31	6.23E-05	7	1.41E-05	23%	Pass
62	2.416	29	5.83E-05	6	1.21E-05	21%	Pass
63	2.451	28	5.63E-05	6	1.21E-05	21%	Pass
64	2.486	23	4.62E-05	6	1.21E-05	26%	Pass
65	2.522	22	4.42E-05	6	1.21E-05	27%	Pass
66	2.557	21	4.22E-05	6	1.21E-05	29%	Pass
67	2.592	21	4.22E-05	6	1.21E-05	29%	Pass
68	2.627	21	4.22E-05	6	1.21E-05	29%	Pass
69	2.662	21	4.22E-05	6	1.21E-05	29%	Pass
70	2.698	21	4.22E-05	6	1.21E-05	29%	Pass
71	2.733	21	4.22E-05	6	1.21E-05	29%	Pass
72	2.768	20	4.02E-05	6	1.21E-05	30%	Pass
73	2.803	20	4.02E-05	6	1.21E-05	30%	Pass
74	2.838	18	3.62E-05	6	1.21E-05	33%	Pass
75	2.873	16	3.22E-05	6	1.21E-05	38%	Pass
76	2.909	15	3.02E-05	6	1.21E-05	40%	Pass
77	2.944	13	2.61E-05	6	1.21E-05	46%	Pass
78	2.979	11	2.21E-05	5	1.01E-05	45%	Pass
79	3.014	9	1.81E-05	5	1.01E-05	56%	Pass
80	3.049	9	1.81E-05	5	1.01E-05	56%	Pass
81	3.085	9	1.81E-05	5	1.01E-05	56%	Pass
82	3.120	9	1.81E-05	5	1.01E-05	56%	Pass
83	3.155	9	1.81E-05	5	1.01E-05	56%	Pass
84	3.190	9	1.81E-05	5	1.01E-05	56%	Pass
85	3.225	8	1.61E-05	5	1.01E-05	63%	Pass
86	3.260	8	1.61E-05	5	1.01E-05	63%	Pass
87	3.296	7	1.41E-05	5	1.01E-05	71%	Pass
88	3.331	7	1.41E-05	5	1.01E-05	71%	Pass
89	3.366	6	1.21E-05	5	1.01E-05	83%	Pass
90	3.401	6	1.21E-05	5	1.01E-05	83%	Pass
91	3.436	6	1.21E-05	5	1.01E-05	83%	Pass
92	3.472	6	1.21E-05	5	1.01E-05	83%	Pass
93	3.507	6	1.21E-05	5	1.01E-05	83%	Pass
94	3.542	6	1.21E-05	5	1.01E-05	83%	Pass
95	3.577	6	1.21E-05	5	1.01E-05	83%	Pass
96	3.612	6	1.21E-05	4	8.04E-06	67%	Pass
97	3.647	6	1.21E-05	4	8.04E-06	67%	Pass
98	3.683	6	1.21E-05	4	8.04E-06	67%	Pass
99	3.718	5	1.01E-05	4	8.04E-06	80%	Pass
100	3.753	5	1.01E-05	4	8.04E-06	80%	Pass

POC-2

Flow Duration Curve [Pre vs. Post (Mitigated)]

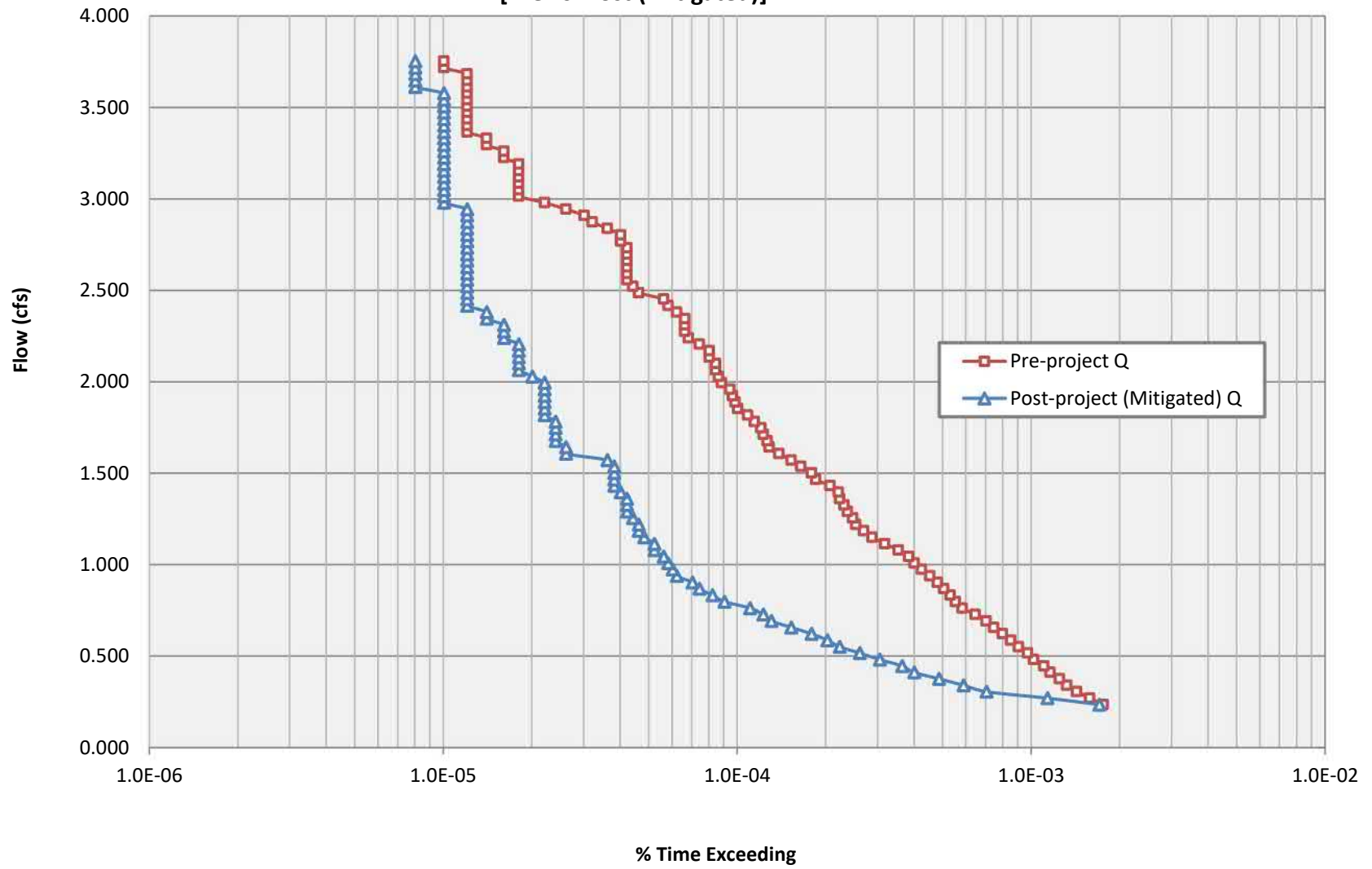

POC-2

**SWMM Model Flow Coefficient Calculation and
Effective Ponding Depth Calculation**

BMP-2

PARAMETER	ABBREV.	Bio-Retention Cell LID BMP	
Ponding Depth	PD	12	in
Bioretention Soil Layer	S	24	in
Permavoid Layer	G	36	in
TOTAL		6.0	ft
		72	in
Orifice Coefficient	c_g	0.6	--
Low Flow Orifice Diameter	D	2	in
Drain exponent	n	0.5	--
Flow Rate (volumetric)	Q	0.256	cfs
Ponding Depth Surface Area	A_{PD}	4500	ft ²
Bioretention Surface Area	A_S, A_G	4500	ft ²
	A_S, A_G	0.1033	ac
Porosity of Bioretention Soil	n	0.40	-
Flow Rate (per unit area)	q	6.132	in/hr
Effective Ponding Depth	PD_{eff}	12.00	in
Flow Coefficient	C	0.2934	--

POC-2

**SWMM Model Flow Coefficient Calculation and
Effective Ponding Depth Calculation**

BMP-3

PARAMETER	ABBREV.	Bio-Retention Cell LID BMP	
Ponding Depth	PD	6	in
Bioretention Soil Layer	S	20	in
Gravel Layer	G	28	in
TOTAL		4.5	ft
		54	in
Orifice Coefficient	c_g	0.6	--
Low Flow Orifice Diameter	D	0.8	in
Drain exponent	n	0.5	--
Flow Rate (volumetric)	Q	0.036	cfs
Ponding Depth Surface Area	A_{PD}	1231	ft ²
Bioretention Surface Area	A_S, A_G	1037	ft ²
	A_S, A_G	0.0238	ac
Porosity of Bioretention Soil	n	0.40	-
Flow Rate (per unit area)	q	3.699	in/hr
Effective Ponding Depth	PD_{eff}	6.56	in
Flow Coefficient	C	0.2037	--

Drawdown Calculation for BMP-2

Project Name

Rincon Guajome

Project No

3775

Surface Drawdown Time:	5.0	hr
Surface Area	4500	sq ft
Underdrain Orifice Diameter: in	2	in
C:	0.6	
Surface Ponding (to invert of lowest surface discharge opening in outlet structure):	1	ft
Amended Soil Depth:	2	ft
Permavoid Depth:	2.75	ft
Orifice Q =	0.250	cfs
Effective Depth	48.15	in
Infiltration controlled by soil	5.000	in/hr
Infiltration controlled by orifice	2.399	in/hr

Drawdown Calculation for BMP-3

Project Name

Rincon Guajome

Project No

3775

Surface Drawdown Time:	4.2	hr
Surface Area	1037	sq ft
Underdrain Orifice Diameter: in	0.8	in
C:	0.6	
Surface Ponding (to invert of lowest surface discharge opening in outlet structure):	0.5	ft
Amended Soil Depth:	1.67	ft
Gravel Depth:	2.08	ft
Orifice Q =	0.034	cfs
Effective Depth	19.992	in
Infiltration controlled by soil	5.000	in/hr
Infiltration controlled by orifice	1.437	in/hr



Manning's n Values for Overland Flow¹

The BMP Design Manuals within the County of San Diego allow for a land surface description other than short prairie grass to be used for hydromodification BMP design only if documentation provided is consistent with Table A.6 of the SWMM 5 User's Manual.

In January 2016, the EPA released the SWMM Reference Manual Volume I – Hydrology (SWMM Hydrology Reference Manual). The SWMM Hydrology Reference Manual complements the SWMM 5 User's Manual by providing an in-depth description of the program's hydrologic components. Table 3-5 of the SWMM Hydrology Reference Manual expounds upon Table A.6 of the SWMM 5 User's Manual by providing Manning's n values for additional overland flow surfaces. Therefore, in order to provide SWMM users with a wider range of land surfaces suitable for local application and to provide Copermitttees with confidence in the design parameters, we recommend using the values published by Yen and Chow in Table 3-5 of the EPA SWMM Reference Manual Volume I – Hydrology. The values are provided in the table below:

Overland Surface	Manning value (n)
Smooth asphalt pavement	0.010
Smooth impervious surface	0.011
Tar and sand pavement	0.012
Concrete pavement	0.014
Rough impervious surface	0.015
Smooth bare packed soil	0.017
Moderate bare packed soil	0.025
Rough bare packed soil	0.032
Gravel soil	0.025
Mowed poor grass	0.030
Average grass, closely clipped sod	0.040
Pasture	0.040
Timberland	0.060
Dense grass	0.060
Shrubs and bushes	0.080
Land Use	
Business	0.014
Semibusiness	0.022
Industrial	0.020
Dense residential	0.025
Suburban residential	0.030
Parks and lawns	0.040

¹Content summarized from *Improving Accuracy in Continuous Simulation Modeling: Guidance for Selecting Pervious Overland Flow Manning's n Values in the San Diego Region* (TRWE, 2016).

Hydrologic Soil Group—San Diego County Area, California



Map Scale: 1:2,970 if printed on A landscape (11" x 8.5") sheet.

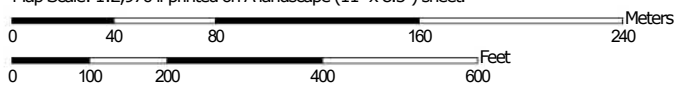

Map projection: Web Mercator Corner coordinates: WGS84 Edge tics: UTM Zone 11N WGS84



MAP LEGEND

Area of Interest (AOI)









 Area of Interest (AOI)

Soils

Soil Rating Polygons





 A
 A/D
 B
 B/D
 C
 C/D
 D
 Not rated or not available

Soil Rating Lines

 A
 A/D
 B
 B/D
 C
 C/D
 D
 Not rated or not available

Soil Rating Points

 A
 A/D
 B
 B/D

 C
 C/D
 D
 Not rated or not available

Water Features

 Streams and Canals

Transportation

 Rails
 Interstate Highways
 US Routes
 Major Roads
 Local Roads

Background

 Aerial Photography

MAP INFORMATION

The soil surveys that comprise your AOI were mapped at 1:24,000.

Warning: Soil Map may not be valid at this scale.

Enlargement of maps beyond the scale of mapping can cause misunderstanding of the detail of mapping and accuracy of soil line placement. The maps do not show the small areas of contrasting soils that could have been shown at a more detailed scale.

Please rely on the bar scale on each map sheet for map measurements.

Source of Map: Natural Resources Conservation Service
 Web Soil Survey URL:
 Coordinate System: Web Mercator (EPSG:3857)

Maps from the Web Soil Survey are based on the Web Mercator projection, which preserves direction and shape but distorts distance and area. A projection that preserves area, such as the Albers equal-area conic projection, should be used if more accurate calculations of distance or area are required.

This product is generated from the USDA-NRCS certified data as of the version date(s) listed below.

Soil Survey Area: San Diego County Area, California
 Survey Area Data: Version 16, Sep 13, 2021

Soil map units are labeled (as space allows) for map scales 1:50,000 or larger.

Date(s) aerial images were photographed: Jan 24, 2020—Feb 12, 2020

The orthophoto or other base map on which the soil lines were compiled and digitized probably differs from the background imagery displayed on these maps. As a result, some minor shifting of map unit boundaries may be evident.

Hydrologic Soil Group

Map unit symbol	Map unit name	Rating	Acres in AOI	Percent of AOI
BsD	Bosanko clay, 9 to 15 percent slopes	D	0.6	3.3%
LeD2	Las Flores loamy fine sand, 9 to 15 percent slopes, eroded	D	9.7	56.4%
LeE2	Las Flores loamy fine sand, 15 to 30 percent slopes, eroded	D	2.9	17.0%
VaB	Visalia sandy loam, 2 to 5 percent slopes	A	4.0	23.2%
Totals for Area of Interest			17.1	100.0%

Description

Hydrologic soil groups are based on estimates of runoff potential. Soils are assigned to one of four groups according to the rate of water infiltration when the soils are not protected by vegetation, are thoroughly wet, and receive precipitation from long-duration storms.

The soils in the United States are assigned to four groups (A, B, C, and D) and three dual classes (A/D, B/D, and C/D). The groups are defined as follows:

Group A. Soils having a high infiltration rate (low runoff potential) when thoroughly wet. These consist mainly of deep, well drained to excessively drained sands or gravelly sands. These soils have a high rate of water transmission.

Group B. Soils having a moderate infiltration rate when thoroughly wet. These consist chiefly of moderately deep or deep, moderately well drained or well drained soils that have moderately fine texture to moderately coarse texture. These soils have a moderate rate of water transmission.

Group C. Soils having a slow infiltration rate when thoroughly wet. These consist chiefly of soils having a layer that impedes the downward movement of water or soils of moderately fine texture or fine texture. These soils have a slow rate of water transmission.

Group D. Soils having a very slow infiltration rate (high runoff potential) when thoroughly wet. These consist chiefly of clays that have a high shrink-swell potential, soils that have a high water table, soils that have a claypan or clay layer at or near the surface, and soils that are shallow over nearly impervious material. These soils have a very slow rate of water transmission.

If a soil is assigned to a dual hydrologic group (A/D, B/D, or C/D), the first letter is for drained areas and the second is for undrained areas. Only the soils that in their natural condition are in group D are assigned to dual classes.

Rating Options

Aggregation Method: Dominant Condition

Component Percent Cutoff: None Specified

Tie-break Rule: Higher

Appendix G: Guidance for Continuous Simulation and Hydromodification Management Sizing Factors

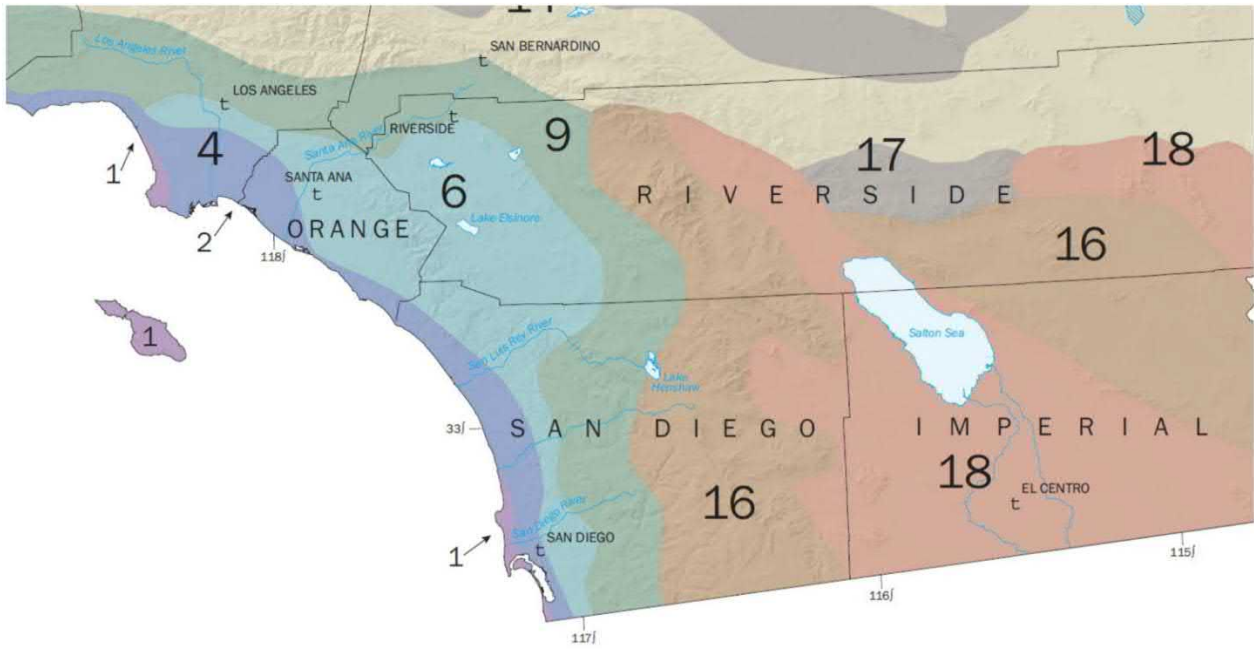

Figure G.1-2: California Irrigation Management Information System "Reference Evapotranspiration Zones"

Appendix G: Guidance for Continuous Simulation and Hydromodification Management Sizing Factors

**Table G.1-1: Monthly Average Reference Evapotranspiration by ETo Zone
(inches/month and inches/day) for use in SWMM Models for Hydromodification Management Studies in San Diego County
CIMIS Zones 1, 4, 6, 9, and 16 (See CIMIS ETo Zone Map)**

	January	February	March	April	May	June	July	August	September	October	November	December
Zone	in/month	in/month	in/month	in/month	in/month	in/month	in/month	in/month	in/month	in/month	in/month	in/month
1	0.93	1.4	2.48	3.3	4.03	4.5	4.65	4.03	3.3	2.48	1.2	0.62
4	1.86	2.24	3.41	4.5	5.27	5.7	5.89	5.58	4.5	3.41	2.4	1.86
6	1.86	2.24	3.41	4.8	5.58	6.3	6.51	6.2	4.8	3.72	2.4	1.86
9	2.17	2.8	4.03	5.1	5.89	6.6	7.44	6.82	5.7	4.03	2.7	1.86
16	1.55	2.52	4.03	5.7	7.75	8.7	9.3	8.37	6.3	4.34	2.4	1.55
	January	February	March	April	May	June	July	August	September	October	November	December
Days	31	28	31	30	31	30	31	31	30	31	30	31
Zone	in/day	in/day	in/day	in/day	in/day	in/day	in/day	in/day	in/day	in/day	in/day	in/day
1	0.030	0.050	0.080	0.110	0.130	0.150	0.150	0.130	0.110	0.080	0.040	0.020
4	0.060	0.080	0.110	0.150	0.170	0.190	0.190	0.180	0.150	0.110	0.080	0.060
6	0.060	0.080	0.110	0.160	0.180	0.210	0.210	0.200	0.160	0.120	0.080	0.060
9	0.070	0.100	0.130	0.170	0.190	0.220	0.240	0.220	0.190	0.130	0.090	0.060
16	0.050	0.090	0.130	0.190	0.250	0.290	0.300	0.270	0.210	0.140	0.080	0.050

Placeholder – **Vector Control Plan** (required when structural BMPs will drain in 96 hours)

Replace placeholder with required documentation.

Leave placeholder intact if not applicable.

Not Applicable



ATTACHMENT 3
STRUCTURAL BMP MAINTENANCE INFORMATION

This is the cover sheet for Attachment 3.



Indicate which Items are Included:

Attachment Sequence	Contents	Checklist
Attachment 3a	Structural BMP Maintenance Thresholds and Actions (Required)	<input checked="" type="checkbox"/> Included See Structural BMP Maintenance Information Checklist.
Attachment 3b	Draft Maintenance Agreement (when applicable)	<input type="checkbox"/> Included <input checked="" type="checkbox"/> Not Applicable



Use this checklist to ensure the required information has been included in the Structural BMP Maintenance Information Attachment:

Preliminary Design / Planning / CEQA level submittal:

- Attachment 3a must identify:
 - Typical maintenance indicators and actions for proposed structural BMP(s) based on Section 7.7 of the BMP Design Manual
- Attachment 3b is not required for preliminary design / planning / CEQA level submittal.

Final Design level submittal:

Attachment 3a must identify:

- Specific maintenance indicators and actions for proposed structural BMP(s). This shall be based on Section 7.7 of the BMP Design Manual and enhanced to reflect actual proposed components of the structural BMP(s)
- How to access the structural BMP(s) to inspect and perform maintenance
- Features that are provided to facilitate inspection (e.g., observation ports, cleanouts, silt posts, or other features that allow the inspector to view necessary components of the structural BMP and compare to maintenance thresholds)
- Manufacturer and part number for proprietary parts of structural BMP(s) when applicable
- Maintenance thresholds specific to the structural BMP(s), with a location-specific frame of reference (e.g., level of accumulated materials that triggers removal of the materials, to be identified based on viewing marks on silt posts or measured with a survey rod with respect to a fixed benchmark within the BMP)
- Recommended equipment to perform maintenance
- When applicable, necessary special training or certification requirements for inspection and maintenance personnel such as confined space entry or hazardous waste management

Attachment 3b: For private entity operation and maintenance, Attachment 3b shall include a draft maintenance agreement in the local jurisdiction's standard format (PDP applicant to contact the City Engineer to obtain the current maintenance agreement forms).



APPENDIX 3a

BMP MAINTENANCE THRESHOLDS

BMP DESCRIPTION

BMP 1 BIOFILTRATION (8,045 SF)	STORM WATER MANAGEMENT AND DISCHARGE CONTROL MAINTENANCE AGREEMENT APPROVAL NO: _____ O&M RESPONSIBLE PARTY DESIGNEE: GUAJOME LAKE ROAD HOMES HOA
POST-CONSTRUCTION PERMANENT BMP OPERATION & MAINTENANCE PROCEDURE DETAILS	
MAINTENANCE INDICATORS	MAINTENANCE ACTION
ACCUMULATION OF SEDIMENT, LITTER, OR DEBRIS	REMOVE AND PROPERLY DISPOSE OF ACCUMULATED MATERIALS, WITHOUT DAMAGE TO THE VEGETATION
POOR VEGETATION ESTABLISHMENT	RE-SEED, RE-PLANT, OR RE-ESTABLISH VEGETATION PER ORIGINAL PLANS
OVERGROWN VEGETATION	MOW OR TRIM AS APPROPRIATE, BUT NOT LESS THAT THE DESIGN HEIGHT OF THE VEGETATION PER ORIGINAL PLANS.
EROSION DUE TO CONCENTRATED IRRIGATION FLOW	REPAIR/RE-SEED/RE-PLANT ERODED AREAS AND ADJUST THE IRRIGATION SYSTEM
EROSION DUE TO CONCENTRATED STORM WATER RUNOFF FLOW	REPAIR/RE-SEED/RE-PLANT ERODED AREAS AND MAKE APPROPRIATE CORRECTIVE MEASURES SUCH AS ADDING STONE AT FLOW ENTRY POINTS OR MINOR RE-GRADING TO RESTORE PROPER DRAINAGE ACCORDING TO THE ORIGINAL PLAN.
STANDING WATER IN BIOFILTRATION AREAS	MAKE APPROPRIATE CORRECTIVE MEASURES SUCH AS ADJUSTING IRRIGATION SYSTEM, REMOVING OBSTRUCTION OF DEBRIS OR INVASIVE VEGETATION, OR CLEANING UNDERDRAINS
OBSTRUCTED INLET OR OUTLET STRUCTURE	CLEAR OBSTRUCTIONS
DAMAGE TO INLET OR OUTLET STRUCTURE	REPAIR OR REPLACE AS APPLICABLE

MAINTENANCE EQUIPMENT AND ACCESS
USE LANDSCAPE EQUIPMENT FOR MAINTENANCE; ACCESS BMP FROM PRIVATE ACCESS ROAD

INSPECTION FACILITATION
INSTALL 3' X 3' OUTLET RISER STRUCTURE TO PROVIDE OBSERVATION ACCESS FOR INSPECTION OF MAINTENANCE THRESHOLDS; MARKING TO BE PROVIDED ON BMP COMPONENTS TO DETERMINE HOW FULL BMP IS.

PASCO LARET SUITER

& ASSOCIATES

CIVIL ENGINEERING + LAND PLANNING + LAND SURVEYING
 535 North Highway 101, Ste A, Solana Beach, CA 92075
 ph 858.259.8212 | fx 858.259.4812 | pascoengineering.com

APPENDIX 3a

BMP MAINTENANCE THRESHOLDS

BMP DESCRIPTION

BMP 2 BIOFILTRATION (4,500 SF)	STORM WATER MANAGEMENT AND DISCHARGE CONTROL MAINTENANCE AGREEMENT APPROVAL NO: _____ O&M RESPONSIBLE PARTY DESIGNEE: GUAJOME LAKE ROAD HOMES HOA
POST-CONSTRUCTION PERMANENT BMP OPERATION & MAINTENANCE PROCEDURE DETAILS	
MAINTENANCE INDICATORS	MAINTENANCE ACTION
ACCUMULATION OF SEDIMENT, LITTER, OR DEBRIS	REMOVE AND PROPERLY DISPOSE OF ACCUMULATED MATERIALS, WITHOUT DAMAGE TO THE VEGETATION
POOR VEGETATION ESTABLISHMENT	RE-SEED, RE-PLANT, OR RE-ESTABLISH VEGETATION PER ORIGINAL PLANS
OVERGROWN VEGETATION	MOW OR TRIM AS APPROPRIATE, BUT NOT LESS THAT THE DESIGN HEIGHT OF THE VEGETATION PER ORIGINAL PLANS.
EROSION DUE TO CONCENTRATED IRRIGATION FLOW	REPAIR/RE-SEED/RE-PLANT ERODED AREAS AND ADJUST THE IRRIGATION SYSTEM
EROSION DUE TO CONCENTRATED STORM WATER RUNOFF FLOW	REPAIR/RE-SEED/RE-PLANT ERODED AREAS AND MAKE APPROPRIATE CORRECTIVE MEASURES SUCH AS ADDING STONE AT FLOW ENTRY POINTS OR MINOR RE-GRADING TO RESTORE PROPER DRAINAGE ACCORDING TO THE ORIGINAL PLAN.
STANDING WATER IN BIOFILTRATION AREAS	MAKE APPROPRIATE CORRECTIVE MEASURES SUCH AS ADJUSTING IRRIGATION SYSTEM, REMOVING OBSTRUCTION OF DEBRIS OR INVASIVE VEGETATION, OR CLEANING UNDERDRAINS
OBSTRUCTED INLET OR OUTLET STRUCTURE	CLEAR OBSTRUCTIONS
DAMAGE TO INLET OR OUTLET STRUCTURE	REPAIR OR REPLACE AS APPLICABLE

MAINTENANCE EQUIPMENT AND ACCESS
USE LANDSCAPE EQUIPMENT FOR MAINTENANCE; ACCESS BMP FROM PRIVATE ACCESS ROAD

INSPECTION FACILITATION
INSTALL 3' X 3' OUTLET RISER STRUCTURE TO PROVIDE OBSERVATION ACCESS FOR INSPECTION OF MAINTENANCE THRESHOLDS; MARKING TO BE PROVIDED ON BMP COMPONENTS TO DETERMINE HOW FULL BMP IS.

PASCO LARET SUITER

& ASSOCIATES

CIVIL ENGINEERING + LAND PLANNING + LAND SURVEYING

535 North Highway 101, Ste A, Solana Beach, CA 92075

ph 858.259.8212 | fx 858.259.4812 | pascengineering.com

APPENDIX 3a

BMP MAINTENANCE THRESHOLDS

BMP DESCRIPTION

BMP 3 BIOFILTRATION (1,037 SF)	STORM WATER MANAGEMENT AND DISCHARGE CONTROL MAINTENANCE AGREEMENT APPROVAL NO: _____ O&M RESPONSIBLE PARTY DESIGNEE: GUAJOME LAKE ROAD HOMES HOA
POST-CONSTRUCTION PERMANENT BMP OPERATION & MAINTENANCE PROCEDURE DETAILS	
MAINTENANCE INDICATORS	MAINTENANCE ACTION
ACCUMULATION OF SEDIMENT, LITTER, OR DEBRIS	REMOVE AND PROPERLY DISPOSE OF ACCUMULATED MATERIALS, WITHOUT DAMAGE TO THE VEGETATION
POOR VEGETATION ESTABLISHMENT	RE-SEED, RE-PLANT, OR RE-ESTABLISH VEGETATION PER ORIGINAL PLANS
OVERGROWN VEGETATION	MOW OR TRIM AS APPROPRIATE, BUT NOT LESS THAT THE DESIGN HEIGHT OF THE VEGETATION PER ORIGINAL PLANS.
EROSION DUE TO CONCENTRATED IRRIGATION FLOW	REPAIR/RE-SEED/RE-PLANT ERODED AREAS AND ADJUST THE IRRIGATION SYSTEM
EROSION DUE TO CONCENTRATED STORM WATER RUNOFF FLOW	REPAIR/RE-SEED/RE-PLANT ERODED AREAS AND MAKE APPROPRIATE CORRECTIVE MEASURES SUCH AS ADDING STONE AT FLOW ENTRY POINTS OR MINOR RE-GRADING TO RESTORE PROPER DRAINAGE ACCORDING TO THE ORIGINAL PLAN.
STANDING WATER IN BIOFILTRATION AREAS	MAKE APPROPRIATE CORRECTIVE MEASURES SUCH AS ADJUSTING IRRIGATION SYSTEM, REMOVING OBSTRUCTION OF DEBRIS OR INVASIVE VEGETATION, OR CLEANING UNDERDRAINS
OBSTRUCTED INLET OR OUTLET STRUCTURE	CLEAR OBSTRUCTIONS
DAMAGE TO INLET OR OUTLET STRUCTURE	REPAIR OR REPLACE AS APPLICABLE

MAINTENANCE EQUIPMENT AND ACCESS
USE LANDSCAPE EQUIPMENT FOR MAINTENANCE; ACCESS BMP FROM PRIVATE ACCESS ROAD

INSPECTION FACILITATION
INSTALL 3' X 3' OUTLET RISER STRUCTURE TO PROVIDE OBSERVATION ACCESS FOR INSPECTION OF MAINTENANCE THRESHOLDS; MARKING TO BE PROVIDED ON BMP COMPONENTS TO DETERMINE HOW FULL BMP IS.

PASCO LARET SUITER

& ASSOCIATES

CIVIL ENGINEERING + LAND PLANNING + LAND SURVEYING

535 North Highway 101, Ste A, Solana Beach, CA 92075

ph 858.259.8212 | fx 858.259.4812 | pascoengineering.com

BF-1

Biofiltration

BMP MAINTENANCE FACT SHEET FOR STRUCTURAL BMP BF-1 BIOFILTRATION

Biofiltration facilities are vegetated surface water systems that filter water through vegetation, and soil or engineered media prior to discharge via underdrain or overflow to the downstream conveyance system. Biofiltration facilities have limited or no infiltration. They are typically designed to provide enough hydraulic head to move flows through the underdrain connection to the storm drain system. Typical biofiltration components include:

- Inflow distribution mechanisms (e.g., perimeter flow spreader or filter strips)
- Energy dissipation mechanism for concentrated inflows (e.g., splash blocks or riprap)
- Shallow surface ponding for captured flows
- Side slope and basin bottom vegetation selected based on climate and ponding depth
- Non-floating mulch layer
- Media layer (planting mix or engineered media) capable of supporting vegetation growth
- Filter course layer consisting of aggregate to prevent the migration of fines into uncompacted native soils or the aggregate storage layer
- Aggregate storage layer with underdrain(s)
- Impermeable liner or uncompacted native soils at the bottom of the facility
- Overflow structure

Normal Expected Maintenance

Biofiltration requires routine maintenance to: remove accumulated materials such as sediment, trash or debris; maintain vegetation health; maintain infiltration capacity of the media layer; replenish mulch; and maintain integrity of side slopes, inlets, energy dissipators, and outlets. A summary table of standard inspection and maintenance indicators is provided within this Fact Sheet.

Non-Standard Maintenance or BMP Failure

If any of the following scenarios are observed, the BMP is not performing as intended to protect downstream waterways from pollution and/or erosion. Corrective maintenance, increased inspection and maintenance, BMP replacement, or a different BMP type will be required.

- The BMP is not drained between storm events. Surface ponding longer than approximately 24 hours following a storm event may be detrimental to vegetation health, and surface ponding longer than approximately 96 hours following a storm event poses a risk of vector (mosquito) breeding. Poor drainage can result from clogging of the media layer, filter course, aggregate storage layer, underdrain, or outlet structure. The specific cause of the drainage issue must be determined and corrected.
- Sediment, trash, or debris accumulation greater than 25% of the surface ponding volume within one month. This means the load from the tributary drainage area is too high, reducing BMP function or clogging the BMP. This would require pretreatment measures within the tributary area draining to the BMP to intercept the materials. Pretreatment components, especially for sediment, will extend the life of components that are more expensive to replace such as media, filter course, and aggregate layers.
- Erosion due to concentrated storm water runoff flow that is not readily corrected by adding erosion control blankets, adding stone at flow entry points, or minor re-grading to restore proper drainage according to the original plan. If the issue is not corrected by restoring the BMP to the original plan and grade, the [City Engineer] shall be contacted prior to any additional repairs or reconstruction.

BF-1

Biofiltration

Other Special Considerations

Biofiltration is a vegetated structural BMP. Vegetated structural BMPs that are constructed in the vicinity of, or connected to, an existing jurisdictional water or wetland could inadvertently result in creation of expanded waters or wetlands. As such, vegetated structural BMPs have the potential to come under the jurisdiction of the United States Army Corps of Engineers, SDRWQCB, California Department of Fish and Wildlife, or the United States Fish and Wildlife Service. This could result in the need for specific resource agency permits and costly mitigation to perform maintenance of the structural BMP. Along with proper placement of a structural BMP, **routine maintenance is key to preventing this scenario.**

BF-1 Biofiltration

SUMMARY OF STANDARD INSPECTION AND MAINTENANCE FOR BF-1 BIOFILTRATION

The property owner is responsible to ensure inspection, operation and maintenance of permanent BMPs on their property unless responsibility has been formally transferred to an agency, community facilities district, homeowners association, property owners association, or other special district.

Maintenance frequencies listed in this table are average/typical frequencies. Actual maintenance needs are site-specific, and maintenance may be required more frequently. Maintenance must be performed whenever needed, based on maintenance indicators presented in this table. The BMP owner is responsible for conducting regular inspections to see when maintenance is needed based on the maintenance indicators. During the first year of operation of a structural BMP, inspection is recommended at least once prior to August 31 and then monthly from September through May. Inspection during a storm event is also recommended. After the initial period of frequent inspections, the minimum inspection and maintenance frequency can be determined based on the results of the first year inspections.

Threshold/Indicator	Maintenance Action	Typical Maintenance Frequency
Accumulation of sediment, litter, or debris	Remove and properly dispose of accumulated materials, without damage to the vegetation or compaction of the media layer.	<ul style="list-style-type: none"> • Inspect monthly. If the BMP is 25% full* or more in one month, increase inspection frequency to monthly plus after every 0.1-inch or larger storm event. • Remove any accumulated materials found at each inspection.
Obstructed inlet or outlet structure	Clear blockage.	<ul style="list-style-type: none"> • Inspect monthly and after every 0.5-inch or larger storm event. • Remove any accumulated materials found at each inspection.
Damage to structural components such as weirs, inlet or outlet structures	Repair or replace as applicable	<ul style="list-style-type: none"> • Inspect annually. • Maintenance when needed.
Poor vegetation establishment	Re-seed, re-plant, or re-establish vegetation per original plans.	<ul style="list-style-type: none"> • Inspect monthly. • Maintenance when needed.
Dead or diseased vegetation	Remove dead or diseased vegetation, re-seed, re-plant, or re-establish vegetation per original plans.	<ul style="list-style-type: none"> • Inspect monthly. • Maintenance when needed.
Overgrown vegetation	Mow or trim as appropriate.	<ul style="list-style-type: none"> • Inspect monthly. • Maintenance when needed.
2/3 of mulch has decomposed, or mulch has been removed	Remove decomposed fraction and top off with fresh mulch to a total depth of 3 inches.	<ul style="list-style-type: none"> • Inspect monthly. • Replenish mulch annually, or more frequently when needed based on inspection.

*"25% full" is defined as ¼ of the depth from the design bottom elevation to the crest of the outflow structure (e.g., if the height to the outflow opening is 12 inches from the bottom elevation, then the materials must be removed when there is 3 inches of accumulation – this should be marked on the outflow structure).

BF-1

Biofiltration

SUMMARY OF STANDARD INSPECTION AND MAINTENANCE FOR BF-1 BIOFILTRATION (Continued from previous page)		
Threshold/Indicator	Maintenance Action	Typical Maintenance Frequency
Erosion due to concentrated irrigation flow	Repair/re-seed/re-plant eroded areas and adjust the irrigation system.	<ul style="list-style-type: none"> • Inspect monthly. • Maintenance when needed.
Erosion due to concentrated storm water runoff flow	Repair/re-seed/re-plant eroded areas, and make appropriate corrective measures such as adding erosion control blankets, adding stone at flow entry points, or minor re-grading to restore proper drainage according to the original plan. If the issue is not corrected by restoring the BMP to the original plan and grade, the [City Engineer] shall be contacted prior to any additional repairs or reconstruction.	<ul style="list-style-type: none"> • Inspect after every 0.5-inch or larger storm event. If erosion due to storm water flow has been observed, increase inspection frequency to after every 0.1-inch or larger storm event. • Maintenance when needed. If the issue is not corrected by restoring the BMP to the original plan and grade, the [City Engineer] shall be contacted prior to any additional repairs or reconstruction.
<p>Standing water in BMP for longer than 24 hours following a storm event</p> <p>Surface ponding longer than approximately 24 hours following a storm event may be detrimental to vegetation health</p>	Make appropriate corrective measures such as adjusting irrigation system, removing obstructions of debris or invasive vegetation, clearing underdrains, or repairing/replacing clogged or compacted soils.	<ul style="list-style-type: none"> • Inspect monthly and after every 0.5-inch or larger storm event. If standing water is observed, increase inspection frequency to after every 0.1-inch or larger storm event. • Maintenance when needed.
<p>Presence of mosquitos/larvae</p> <p>For images of egg rafts, larva, pupa, and adult mosquitos, see http://www.mosquito.org/biology</p>	<p>If mosquitos/larvae are observed: first, immediately remove any standing water by dispersing to nearby landscaping; second, make corrective measures as applicable to restore BMP drainage to prevent standing water.</p> <p>If mosquitos persist following corrective measures to remove standing water, or if the BMP design does not meet the 96-hour drawdown criteria due to release rates controlled by an orifice installed on the underdrain, the [City Engineer] shall be contacted to determine a solution. A different BMP type, or a Vector Management Plan prepared with concurrence from the County of San Diego Department of Environmental Health, may be required.</p>	<ul style="list-style-type: none"> • Inspect monthly and after every 0.5-inch or larger storm event. If mosquitos are observed, increase inspection frequency to after every 0.1-inch or larger storm event. • Maintenance when needed.
Underdrain clogged	Clear blockage.	<ul style="list-style-type: none"> • Inspect if standing water is observed for longer than 24-96 hours following a storm event. • Maintenance when needed.

BF-1

Biofiltration

References

American Mosquito Control Association.

<http://www.mosquito.org/>

California Storm Water Quality Association (CASQA). 2003. Municipal BMP Handbook.

<https://www.casqa.org/resources/bmp-handbooks/municipal-bmp-handbook>

County of San Diego. 2014. Low Impact Development Handbook.

<http://www.sandiegocounty.gov/content/sdc/dpw/watersheds/susmp/lid.html>

San Diego County Copermittees. 2016. Model BMP Design Manual, Appendix E, Fact Sheet BF-1.

http://www.projectcleanwater.org/index.php?option=com_content&view=article&id=250&Itemid=220

BF-1

Biofiltration

Page Intentionally Blank for Double-Sided Printing

BF-1 Biofiltration

Date:	Inspector:	BMP ID No.:
Permit No.:	APN(s):	
Property / Development Name:		Responsible Party Name and Phone Number:
Property Address of BMP:		Responsible Party Address:

INSPECTION AND MAINTENANCE CHECKLIST FOR BF-1 BIOFILTRATION PAGE 1 of 5			
Threshold/Indicator	Maintenance Recommendation	Date	Description of Maintenance Conducted
Accumulation of sediment, litter, or debris Maintenance Needed? <input type="checkbox"/> YES <input type="checkbox"/> NO <input type="checkbox"/> N/A	<input type="checkbox"/> Remove and properly dispose of accumulated materials, without damage to the vegetation <input type="checkbox"/> If sediment, litter, or debris accumulation exceeds 25% of the surface ponding volume within one month (25% full*), add a forebay or other pre-treatment measures within the tributary area draining to the BMP to intercept the materials. <input type="checkbox"/> Other / Comments:		
Poor vegetation establishment Maintenance Needed? <input type="checkbox"/> YES <input type="checkbox"/> NO <input type="checkbox"/> N/A	<input type="checkbox"/> Re-seed, re-plant, or re-establish vegetation per original plans <input type="checkbox"/> Other / Comments:		

*"25% full" is defined as ¼ of the depth from the design bottom elevation to the crest of the outflow structure (e.g., if the height to the outflow opening is 12 inches from the bottom elevation, then the materials must be removed when there is 3 inches of accumulation – this should be marked on the outflow structure).

BF-1 Biofiltration

Date:	Inspector:	BMP ID No.:
Permit No.:	APN(s):	

INSPECTION AND MAINTENANCE CHECKLIST FOR BF-1 BIOFILTRATION PAGE 2 of 5			
Threshold/Indicator	Maintenance Recommendation	Date	Description of Maintenance Conducted
Dead or diseased vegetation Maintenance Needed? <input type="checkbox"/> YES <input type="checkbox"/> NO <input type="checkbox"/> N/A	<input type="checkbox"/> Remove dead or diseased vegetation, re-seed, re-plant, or re-establish vegetation per original plans <input type="checkbox"/> Other / Comments:		
Overgrown vegetation Maintenance Needed? <input type="checkbox"/> YES <input type="checkbox"/> NO <input type="checkbox"/> N/A	<input type="checkbox"/> Mow or trim as appropriate <input type="checkbox"/> Other / Comments:		
2/3 of mulch has decomposed, or mulch has been removed Maintenance Needed? <input type="checkbox"/> YES <input type="checkbox"/> NO <input type="checkbox"/> N/A	<input type="checkbox"/> Remove decomposed fraction and top off with fresh mulch to a total depth of 3 inches <input type="checkbox"/> Other / Comments:		

BF-1 Biofiltration

Date:	Inspector:	BMP ID No.:
Permit No.:	APN(s):	

INSPECTION AND MAINTENANCE CHECKLIST FOR BF-1 BIOFILTRATION PAGE 3 of 5			
Threshold/Indicator	Maintenance Recommendation	Date	Description of Maintenance Conducted
Erosion due to concentrated irrigation flow Maintenance Needed? <input type="checkbox"/> YES <input type="checkbox"/> NO <input type="checkbox"/> N/A	<input type="checkbox"/> Repair/re-seed/re-plant eroded areas and adjust the irrigation system <input type="checkbox"/> Other / Comments:		
Erosion due to concentrated storm water runoff flow Maintenance Needed? <input type="checkbox"/> YES <input type="checkbox"/> NO <input type="checkbox"/> N/A	<input type="checkbox"/> Repair/re-seed/re-plant eroded areas, and make appropriate corrective measures such as adding erosion control blankets, adding stone at flow entry points, or minor re-grading to restore proper drainage according to the original plan <input type="checkbox"/> If the issue is not corrected by restoring the BMP to the original plan and grade, the [City Engineer] shall be contacted prior to any additional repairs or reconstruction <input type="checkbox"/> Other / Comments:		

BF-1 Biofiltration

Date:	Inspector:	BMP ID No.:
Permit No.:	APN(s):	

INSPECTION AND MAINTENANCE CHECKLIST FOR BF-1 BIOFILTRATION PAGE 4 of 5			
Threshold/Indicator	Maintenance Recommendation	Date	Description of Maintenance Conducted
Obstructed inlet or outlet structure Maintenance Needed? <input type="checkbox"/> YES <input type="checkbox"/> NO <input type="checkbox"/> N/A	<input type="checkbox"/> Clear blockage <input type="checkbox"/> Other / Comments:		
Underdrain clogged (inspect underdrain if standing water is observed for longer than 24-96 hours following a storm event) Maintenance Needed? <input type="checkbox"/> YES <input type="checkbox"/> NO <input type="checkbox"/> N/A	<input type="checkbox"/> Clear blockage <input type="checkbox"/> Other / Comments:		
Damage to structural components such as weirs, inlet or outlet structures Maintenance Needed? <input type="checkbox"/> YES <input type="checkbox"/> NO <input type="checkbox"/> N/A	<input type="checkbox"/> Repair or replace as applicable <input type="checkbox"/> Other / Comments:		

BF-1 Biofiltration

Date:	Inspector:	BMP ID No.:
Permit No.:	APN(s):	

INSPECTION AND MAINTENANCE CHECKLIST FOR BF-1 BIOFILTRATION PAGE 5 of 5			
Threshold/Indicator	Maintenance Recommendation	Date	Description of Maintenance Conducted
<p>Standing water in BMP for longer than 24-96 hours following a storm event*</p> <p>Surface ponding longer than approximately 24 hours following a storm event may be detrimental to vegetation health</p> <p>Maintenance Needed?</p> <p><input type="checkbox"/> YES <input type="checkbox"/> NO <input type="checkbox"/> N/A</p>	<p><input type="checkbox"/> Make appropriate corrective measures such as adjusting irrigation system, removing obstructions of debris or invasive vegetation, clearing underdrains, or repairing/replacing clogged or compacted soils</p> <p><input type="checkbox"/> Other / Comments:</p>		
<p>Presence of mosquitos/larvae</p> <p>For images of egg rafts, larva, pupa, and adult mosquitos, see http://www.mosquito.org/biology</p> <p>Maintenance Needed?</p> <p><input type="checkbox"/> YES <input type="checkbox"/> NO <input type="checkbox"/> N/A</p>	<p><input type="checkbox"/> Apply corrective measures to remove standing water in BMP when standing water occurs for longer than 24-96 hours following a storm event.**</p> <p><input type="checkbox"/> Other / Comments:</p>		

*Surface ponding longer than approximately 24 hours following a storm event may be detrimental to vegetation health, and surface ponding longer than approximately 96 hours following a storm event poses a risk of vector (mosquito) breeding. Poor drainage can result from clogging of the media layer, filter course, aggregate storage layer, underdrain, or outlet structure. The specific cause of the drainage issue must be determined and corrected.

**If mosquitos persist following corrective measures to remove standing water, or if the BMP design does not meet the 96-hour drawdown criteria due to release rates controlled by an orifice installed on the underdrain, the [City Engineer] shall be contacted to determine a solution. A different BMP type, or a Vector Management Plan prepared with concurrence from the County of San Diego Department of Environmental Health, may be required.

R-TANK MAINTENANCE

Designing an underground stormwater detention system with future maintenance in mind is a simple process that includes three primary objectives: **PREVENT** debris from entering the system by using good pre-treatment systems, **ISOLATE** debris and sediments that manage to enter the system, and **PROTECT** the body of the system by providing backflush mechanisms to ensure longevity.

1. PREVENT

Keeping debris and sediment out of the system by pre-treating runoff is one of the smartest things an engineer can do when designing underground detention systems. It makes no sense to allow trash and sediments to flow unrestricted into an underground system where removal will be expensive. Instead, capture pollutants simply and inexpensively in the inlets, where removal is easy. There are several ways this can be accomplished with minimal cost impacts to your project.

Trash Guard Plus®

Trash Guard Plus is a patented stormwater pretreatment device that traps debris, sediment and floatables in the inlet. It helps extend maintenance cycles by using the full volume of the inlet structure for sediment capacity. And it is easy to maintain by accessing pollutants through the manhole lid.



Trash Guard Plus®

Trash Guard Plus works by both screening debris out of the runoff and by slowing the flow of runoff, causing sediments to fall to the bottom of the inlet. Testing at NC State has shown the Trash Guard to be effective at removing trash, sediment, nutrients, and metals.

Gratemaster

To treat a single inlet that serves as a junction for a larger drainage area, consider an insert like the Gratemaster. Ideal for capturing sediment and trash, it makes clean-up a snap by holding all the pollutants right near the surface for easy extraction.

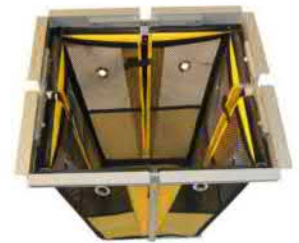

Gratemaster

R-Tank Screening

For a more centralized approach, some engineers prefer to create an opening in the inlet structures to allow the R-Tank modules to penetrate the structure to act as a trash screen. This works best with a structure that includes a sump (see drawing below).

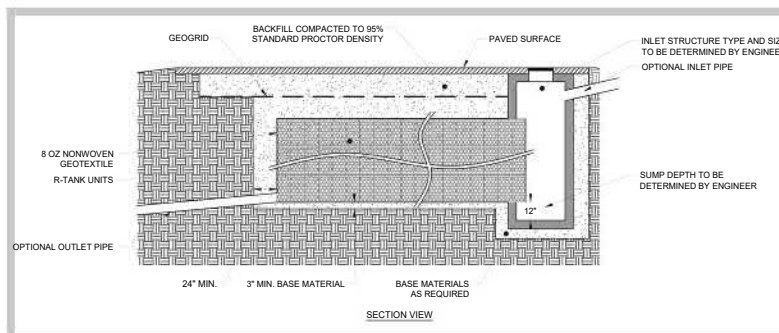

R-TANK MAINTENANCE

2. ISOLATE

Some pollutants may elude the pre-treatment systems. Trap these materials inside the maintenance row (see drawing to right). Consolidating sediments in a single location makes them easy to remove. Maintenance rows are formed by using maintenance modules, which have open internal components that are fully accessible by conventional jet-vac systems. These modules are set in a row (or multiple rows) to your desired length. Longer maintenance rows should include an access structure on both ends. Extremely long rows may require access from the middle of the row, as well.

The maintenance row is always wrapped in geotextile independently from the rest of the system. The geotextile retains trash, sediments, and other solids, preventing contamination of the rest of the system.

The maintenance row should be sized to treat the first flush (usually 1") of runoff. Use a bypass structure to divert that flow into the maintenance row, and allow larger flows to continue to a downstream inlet where they can enter the R-Tank outside of the maintenance row.

The maintenance row is only available in LD, HD, and UD modules. For SD and XD modules, consider creating a forebay around the inlet locations to collect sediment. This is done by using a taller module installed at a lower invert. Geotextile baffles between the forebay and the rest of the system can help retain sediments. Concentrate Maintenance Ports (see PROTECT below) in the forebay to ensure access to sediment for removal.

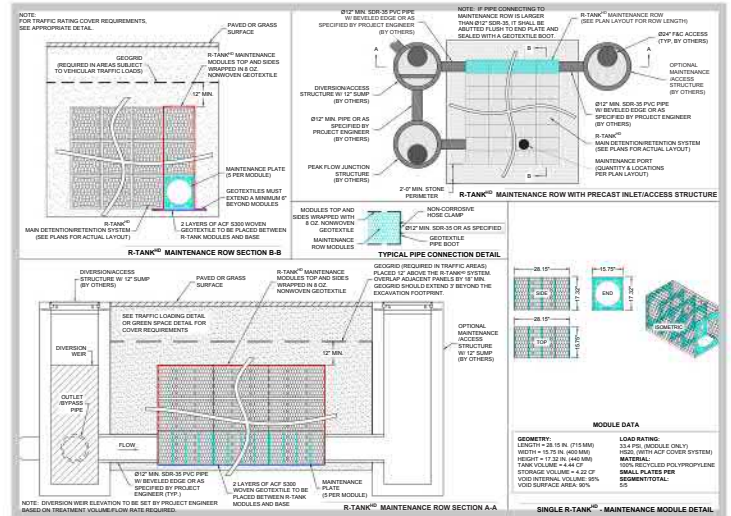

3. PROTECT

Every good system has a fall-back plan. You can ensure a long system life by including maintenance ports throughout the system footprint to remove any pollutants that evade the pretreatment system and maintenance row. Maintenance ports should be specified within 10' of inlet and outlet connections, and roughly 50' on center (see maintenance port detail to right).

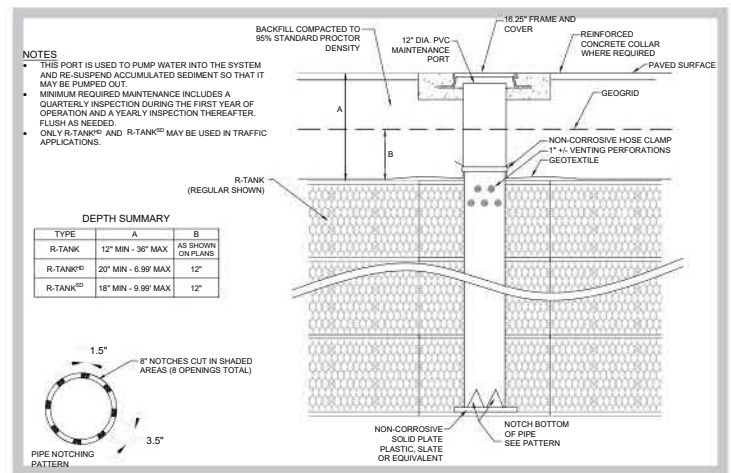

ATTACHMENT 4
Copy of Plan Sheets Showing Permanent Storm Water BMPs

This is the cover sheet for Attachment 4.



Use this checklist to ensure the required information has been included on the plans:

The plans must identify:

- Structural BMP(s) with ID numbers matching Form I-6 Summary of PDP Structural BMPs
- The grading and drainage design shown on the plans must be consistent with the delineation of DMAs shown on the DMA exhibit
- Details and specifications for construction of structural BMP(s)
- Signage indicating the location and boundary of structural BMP(s) as required by the City Engineer
- How to access the structural BMP(s) to inspect and perform maintenance
- Features that are provided to facilitate inspection (e.g., observation ports, cleanouts, silt posts, or other features that allow the inspector to view necessary components of the structural BMP and compare to maintenance thresholds)
- Manufacturer and part number for proprietary parts of structural BMP(s) when applicable
- Maintenance thresholds specific to the structural BMP(s), with a location-specific frame of reference (e.g., level of accumulated materials that triggers removal of the materials, to be identified based on viewing marks on silt posts or measured with a survey rod with respect to a fixed benchmark within the BMP)
- Recommended equipment to perform maintenance
- When applicable, necessary special training or certification requirements for inspection and maintenance personnel such as confined space entry or hazardous waste management
- Include landscaping plan sheets showing vegetation requirements for vegetated structural BMP(s)
- All BMPs must be fully dimensioned on the plans
- When proprietary BMPs are used, site specific cross section with outflow, inflow and model number shall be provided. Broucher photocopies are not allowed.



Placeholder – **Stormwater BMP Plan Sheet(s)**

Replace placeholder with plan sheet(s).



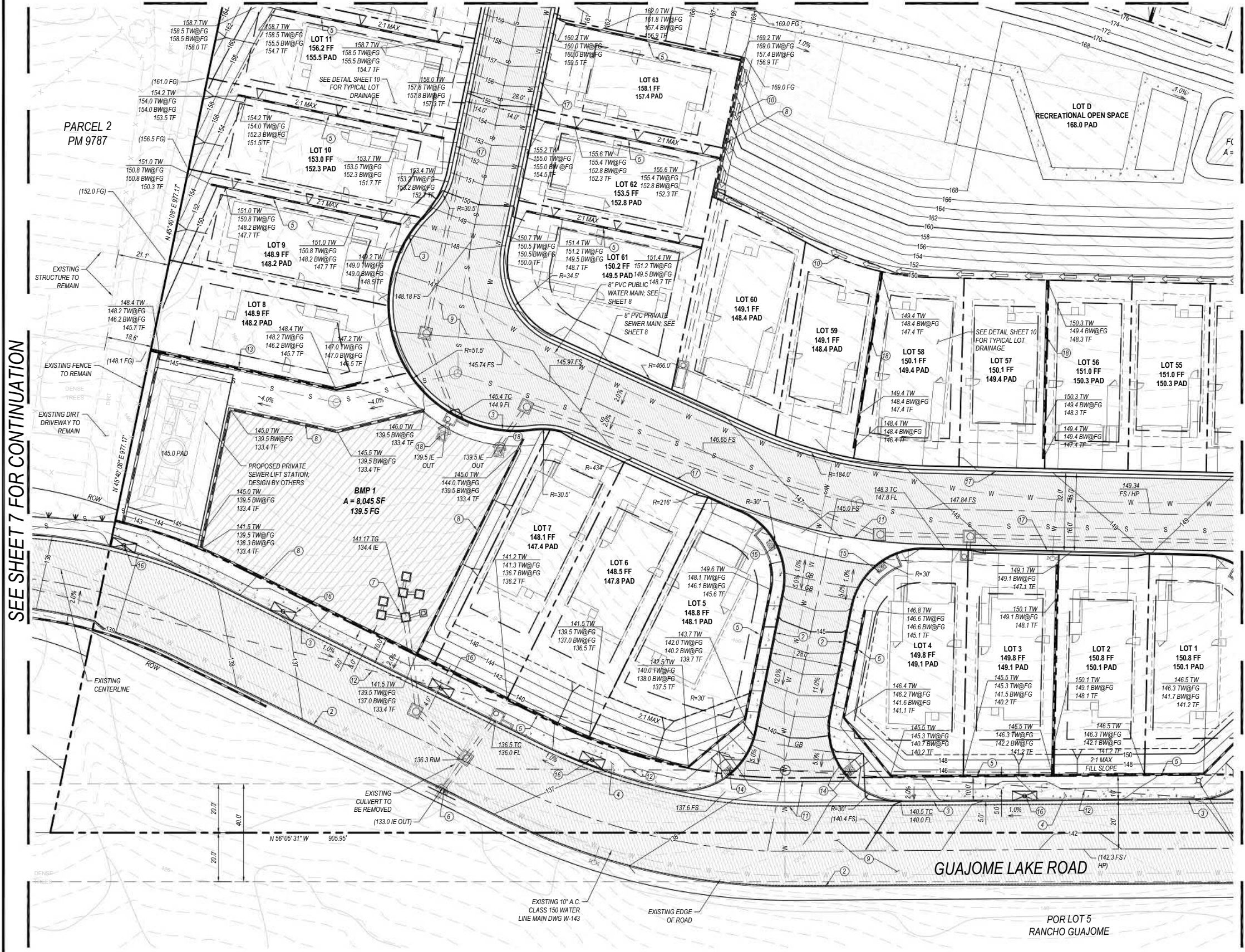

LEGEND

PROPERTY LINE	---
RIGHT-OF-WAY	---
CENTERLINE OF ROAD	---
PROPOSED LOT LINES	---
ADJACENT LOT LINES	---
PROPOSED EASEMENTS	---
PROPOSED SETBACKS	---
PROPOSED LIMIT OF GRADING	---
PROPOSED CONTOUR	---
EXISTING CONTOUR	---
PROPOSED 6" CURB & GUTTER	---
PROPOSED 6" CURB	---
PROPOSED HARDSCAPE	---
PROPOSED MASONRY RETAINING WALL	---
PROPOSED BMP	---
EXISTING WATER MAIN (SIZE PER PLAN)	---
EXISTING SEWER MAIN (SIZE PER PLAN)	---
EXISTING STORM DRAIN (SIZE PER PLAN)	---
EXISTING GAS MAIN	---
PROPOSED SEWER MANHOLE	---
PROPOSED 4" PVC STORM DRAIN	---
PROPOSED 18" RCP PRIVATE STORM DRAIN	---
PROPOSED 12" AREA DRAIN	---
PROPOSED 8" PRIVATE PVC SEWER MAIN	---
PROPOSED 8" PVC PUBLIC WATER MAIN	---

- CONSTRUCTION NOTES**
- EXISTING SURVEY MONUMENT TO BE PROTECTED IN PLACE; CORNER RECORD OR RECORD OF SURVEY TO BE FILED WITH THE COUNTY IF DISTURBED OR DESTROYED
 - PROPOSED 6" PCC CURB PER SDRSD G-1 W/ CLASS II BASE
 - PROPOSED 6" PCC CURB & GUTTER PER SDRSD G-2 W/ CLASS II BASE
 - PROPOSED 5" WIDE, 4" THICK PCC SIDEWALK PER SDRSD G-7 W/ CLASS II BASE
 - PROPOSED MASONRY RETAINING WALL PER SDRSD C-04
 - PROPOSED WING-TYPE PCC HEADWALL WITH 4'x4' RIP RAP ENERGY DISSIPATOR PER SDRSD D-34 & 40; ROCK CLASS = No. 2 BACKING T = 1.1 FT
 - PROPOSED 36" X 36" BROOKS BOX OUTLET STRUCTURE; SEE BIOFILTRATION BASIN DETAIL SHEET 11
 - PROPOSED MASONRY RETAINING WALL SYSTEM; DESIGN BY OTHERS
 - PROPOSED 4" AC PAVEMENT OVER 6" CLASS II AB OR PER GEOTECH RECOMMENDATIONS
 - PROPOSED PCC BROW DITCH PER SDRSD D-75, TYPE B
 - PROPOSED PCC CROSS GUTTER PER SDRSD G-12
 - SIGHT DISTANCE VIEW CORRIDOR PER CALTRANS HIGHWAY DESIGN MANUAL AND CITY OF OCEANSIDE STANDARDS
 - PROPOSED MASONRY RETAINING WALL PER SDRSD C-03
 - PROPOSED PCC PED RAMP PER SDRSD G-27
 - PROPOSED PCC PED RAMP PER SDRSD G-29
 - PROPOSED TREE WELL BMP (4' X 10'); SEE DETAIL SHEET 11
 - PROPOSED ROLLED / MOUNTABLE PCC CURB AND GUTTER PER SDRSD G-04A W/ CLASS II BASE
 - PROPOSED RIP RAP ENERGY DISSIPATOR PER SDRSD D-40; ROCK CLASS = 2 TON T=5.4'
 - PROPOSED 6" PCC ROLLED CURB PER SDRSD G-04A W/ CLASS II BASE, MODIFIED WITHOUT GUTTER

CONSTRUCTION SITE NOTES

1. ALL UTILITIES SHOWN HEREON PER BEST AVAILABLE RECORDS. CONTRACTOR SHALL VERIFY EXACT HORIZONTAL AND VERTICAL LOCATION PRIOR TO CONSTRUCTION. CONTRACTOR SHALL NOTIFY ENGINEER OF RECORD OF DISCREPANCIES UPON DISCOVERY.

EXISTING EASEMENT NOTES

SEE SHEET 1 FOR PLOTTING AND SUMMARY OF EXISTING EASEMENTS

PROPOSED EASEMENT NOTES

SEE SHEET 2 FOR SUMMARY OF PROPOSED EASEMENTS



PLAN VIEW - PRELIMINARY GRADING PLAN
SCALE: 1" = 20'

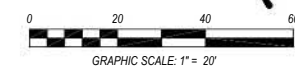

PASCO LARET SUITER & ASSOCIATES
San Diego | Solana Beach | Orange County
Phone 858.259.8212 | www.plsaengineering.com



SEE SHEET 3 FOR CONTINUATION

LEGEND

PROPERTY LINE	---
RIGHT-OF-WAY	---
CENTERLINE OF ROAD	---
PROPOSED LOT LINES	---
ADJACENT LOT LINES	---
PROPOSED EASEMENTS	---
PROPOSED SETBACKS	---
PROPOSED LIMIT OF GRADING	---
PROPOSED CONTOUR	---
EXISTING CONTOUR	---
PROPOSED 6" CURB & GUTTER	---
PROPOSED 6" CURB	---
PROPOSED HARDSCAPE	---
PROPOSED MASONRY RETAINING WALL	---
PROPOSED BMP	---
EXISTING WATER MAIN (SIZE PER PLAN)	---
EXISTING SEWER MAIN (SIZE PER PLAN)	---
EXISTING STORM DRAIN (SIZE PER PLAN)	---
EXISTING GAS MAIN	---
PROPOSED SEWER MANHOLE	---
PROPOSED 4" PVC STORM DRAIN	---
PROPOSED 18" RCP PRIVATE STORM DRAIN	---
PROPOSED 12" AREA DRAIN	---
PROPOSED 8" PRIVATE PVC SEWER MAIN	---
PROPOSED 8" PVC PUBLIC WATER MAIN	---

- CONSTRUCTION NOTES**
- EXISTING SURVEY MONUMENT TO BE PROTECTED IN PLACE; CORNER RECORD OR RECORD OF SURVEY TO BE FILED WITH THE COUNTY IF DISTURBED OR DESTROYED
 - PROPOSED 6" PCC CURB PER SDRSD G-1 W/ CLASS II BASE
 - PROPOSED 6" PCC CURB & GUTTER PER SDRSD G-2 W/ CLASS II BASE
 - PROPOSED 5" WIDE, 4" THICK PCC SIDEWALK PER SDRSD G-7 W/ CLASS II BASE
 - PROPOSED MASONRY RETAINING WALL PER SDRSD C-04
 - PROPOSED WING-TYPE PCC HEADWALL WITH 4'X4' RIP RAP ENERGY DISSIPATOR PER SDRSD D-34 & 40; ROCK CLASS = No. 2 BACKING T = 1.1 FT
 - PROPOSED 36" X 36" BROOKS BOX OUTLET STRUCTURE; SEE BIOFILTRATION BASIN DETAIL SHEET 11
 - PROPOSED MASONRY RETAINING WALL SYSTEM; DESIGN BY OTHERS
 - PROPOSED 4" AC PAVEMENT OVER 6" CLASS II AB OR PER GEOTECH RECOMMENDATIONS
 - PROPOSED PCC BROW DITCH PER SDRSD D-75, TYPE B
 - PROPOSED PCC CROSS GUTTER PER SDRSD G-12
 - SIGHT DISTANCE VIEW CORRIDOR PER CALTRANS HIGHWAY DESIGN MANUAL AND CITY OF OCEANSIDE STANDARDS
 - PROPOSED MASONRY RETAINING WALL PER SDRSD C-03
 - PROPOSED PCC PED RAMP PER SDRSD G-27
 - PROPOSED PCC PED RAMP PER SDRSD G-29
 - PROPOSED TREE WELL BMP (4' X 10'); SEE DETAIL SHEET 11
 - PROPOSED ROLLED / MOUNTABLE PCC CURB AND GUTTER PER SDRSD G-04A W/ CLASS II BASE
 - PROPOSED RIP RAP ENERGY DISSIPATOR PER SDRSD D-40; ROCK CLASS = 2 TON T=5.4'
 - PROPOSED 6" PCC ROLLED CURB PER SDRSD G-04A W/ CLASS II BASE, MODIFIED WITHOUT GUTTER

CONSTRUCTION SITE NOTES

1. ALL UTILITIES SHOWN HEREON PER BEST AVAILABLE RECORDS. CONTRACTOR SHALL VERIFY EXACT HORIZONTAL AND VERTICAL LOCATION PRIOR TO CONSTRUCTION. CONTRACTOR SHALL NOTIFY ENGINEER OF RECORD OF DISCREPANCIES UPON DISCOVERY.

EXISTING EASEMENT NOTES

SEE SHEET 1 FOR PLOTTING AND SUMMARY OF EXISTING EASEMENTS

PROPOSED EASEMENT NOTES

SEE SHEET 2 FOR SUMMARY OF PROPOSED EASEMENTS



PLAN VIEW - PRELIMINARY GRADING PLAN
SCALE: 1" = 20'

SEE SHEET 6 FOR CONTINUATION

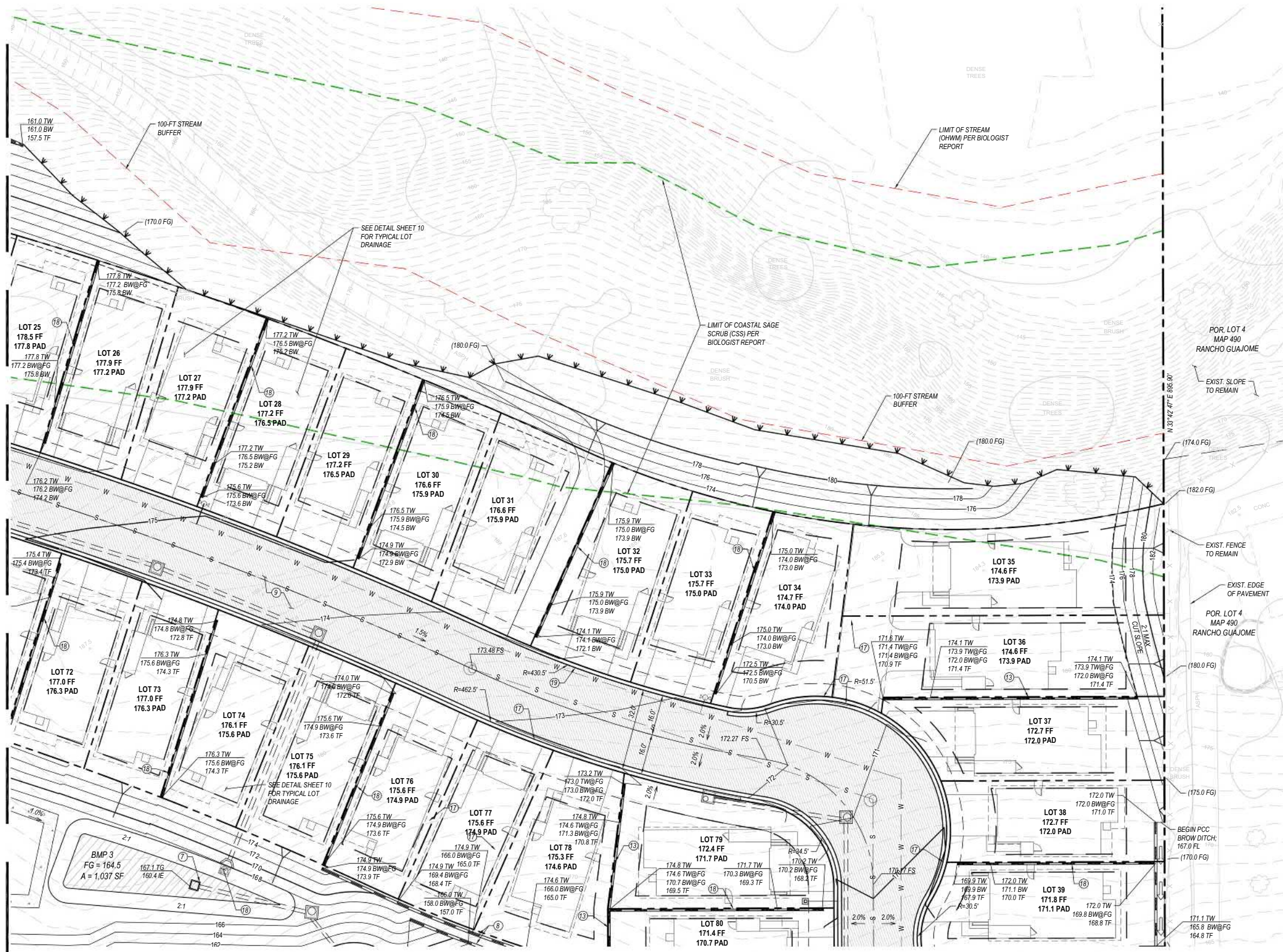

SEE SHEET 4 FOR CONTINUATION

PLAN VIEW - PRELIMINARY GRADING PLAN

SCALE: 1" = 20'

LEGEND

PROPERTY LINE	---
RIGHT-OF-WAY	---
CENTERLINE OF ROAD	---
PROPOSED LOT LINES	---
ADJACENT LOT LINES	---
PROPOSED EASEMENTS	---
PROPOSED SETBACKS	---
PROPOSED LIMIT OF GRADING	---
PROPOSED CONTOUR	---
EXISTING CONTOUR	---
PROPOSED 6" CURB & GUTTER	---
PROPOSED 6" CURB	---
PROPOSED HARDSCAPE	---
PROPOSED MASONRY RETAINING WALL	---
PROPOSED BMP	---
EXISTING WATER MAIN (SIZE PER PLAN)	W
EXISTING SEWER MAIN (SIZE PER PLAN)	S
EXISTING STORM DRAIN (SIZE PER PLAN)	G
EXISTING GAS MAIN	G
PROPOSED SEWER MANHOLE	⊙
PROPOSED 4" PVC STORM DRAIN	SD
PROPOSED 18" RCP PRIVATE STORM DRAIN	---
PROPOSED 12" AREA DRAIN	---
PROPOSED 8" PRIVATE PVC SEWER MAIN	S
PROPOSED 8" PVC PUBLIC WATER MAIN	W

CONSTRUCTION NOTES

- EXISTING SURVEY MONUMENT TO BE PROTECTED IN PLACE; CORNER RECORD OR RECORD OF SURVEY TO BE FILED WITH THE COUNTY IF DISTURBED OR DESTROYED
- PROPOSED 6" PCC CURB PER SDRSD G-1 W/ CLASS II BASE
- PROPOSED 6" PCC CURB & GUTTER PER SDRSD G-2 W/ CLASS II BASE
- PROPOSED 5" WIDE, 4" THICK PCC SIDEWALK PER SDRSD G-7 W/ CLASS II BASE
- PROPOSED MASONRY RETAINING WALL PER SDRSD C-04
- PROPOSED WING-TYPE PCC HEADWALL WITH 4x4 RIP RAP ENERGY DISSIPATER PER SDRSD D-34 & 40; ROCK CLASS = No. 2 BACKING T = 1.1 FT
- PROPOSED 36" X 36" BROOKS BOX OUTLET STRUCTURE; SEE BIOFILTRATION BASIN DETAIL SHEET 11
- PROPOSED MASONRY RETAINING WALL SYSTEM; DESIGN BY OTHERS
- PROPOSED 4" AC PAVEMENT OVER 6" CLASS II AB OR PER GEOTECH RECOMMENDATIONS
- PROPOSED PCC BROW DITCH PER SDRSD D-75, TYPE B
- PROPOSED PCC CROSS GUTTER PER SDRSD G-12
- SIGHT DISTANCE VIEW CORRIDOR PER CALTRANS HIGHWAY DESIGN MANUAL AND CITY OF OCEANSIDE STANDARDS
- PROPOSED MASONRY RETAINING WALL PER SDRSD C-03
- PROPOSED PCC PED RAMP PER SDRSD G-27
- PROPOSED PCC PED RAMP PER SDRSD G-29
- PROPOSED TREE WELL BMP (4' X 10'); SEE DETAIL SHEET 11
- PROPOSED ROLLED / MOUNTABLE PCC CURB AND GUTTER PER SDRSD G-04A W/ CLASS II BASE
- PROPOSED RIP RAP ENERGY DISSIPATER PER SDRSD D-40; ROCK CLASS = 2 TON T=5.4'
- PROPOSED 6" PCC ROLLED CURB PER SDRSD G-04A W/ CLASS II BASE, MODIFIED WITHOUT GUTTER

CONSTRUCTION SITE NOTES

1. ALL UTILITIES SHOWN HEREON PER BEST AVAILABLE RECORDS. CONTRACTOR SHALL VERIFY EXACT HORIZONTAL AND VERTICAL LOCATION PRIOR TO CONSTRUCTION. CONTRACTOR SHALL NOTIFY ENGINEER OF RECORD OF DISCREPANCIES UPON DISCOVERY.

EXISTING EASEMENT NOTES

SEE SHEET 1 FOR PLOTTING AND SUMMARY OF EXISTING EASEMENTS

PROPOSED EASEMENT NOTES

SEE SHEET 2 FOR SUMMARY OF PROPOSED EASEMENTS

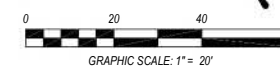

PASCO LARET SUITER & ASSOCIATES
San Diego | Solana Beach | Orange County
Phone 858.259.8212 | www.plsaengineering.com

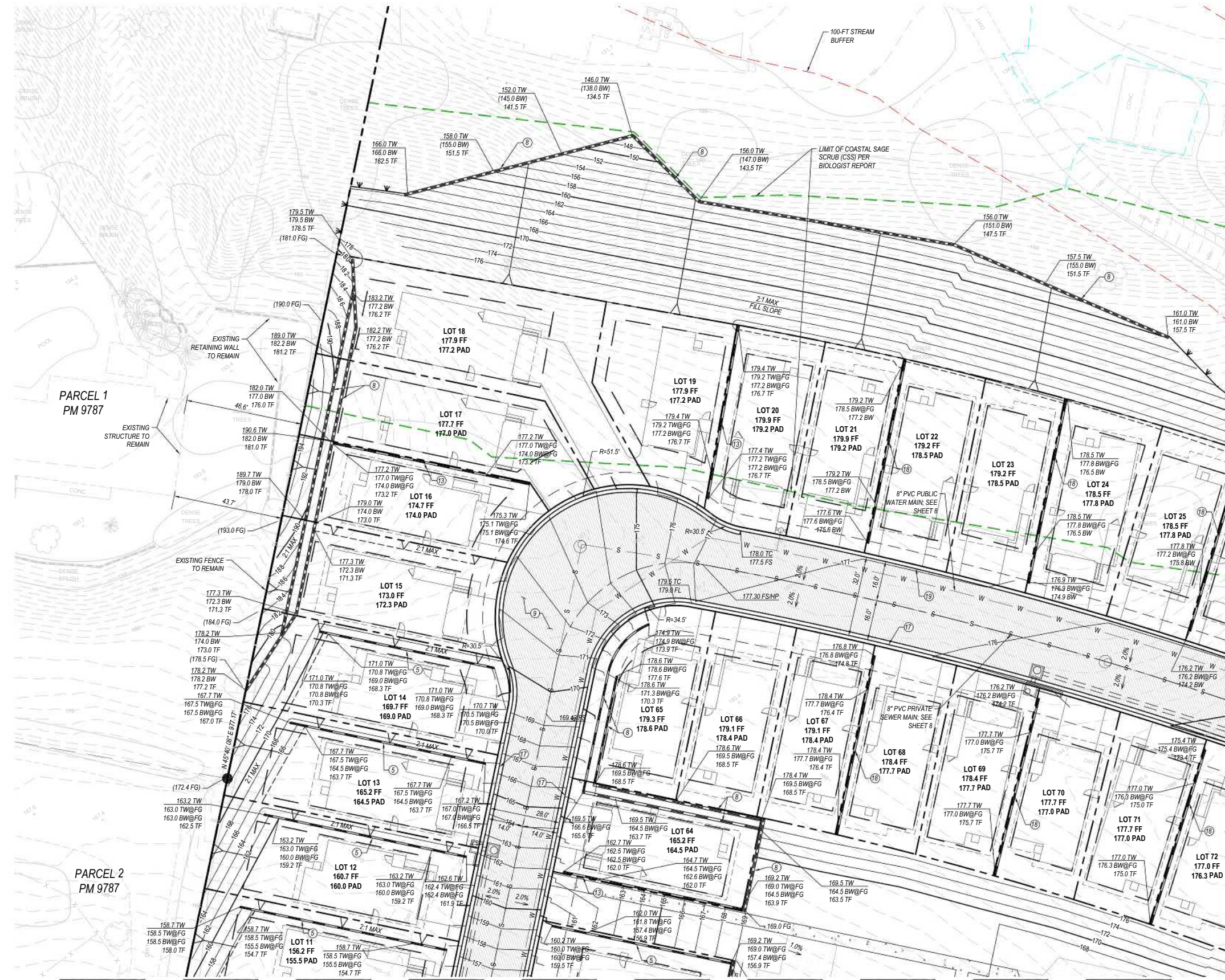

SEE SHEET 5 FOR CONTINUATION

LEGEND

PROPERTY LINE	---
RIGHT-OF-WAY	---
CENTERLINE OF ROAD	---
PROPOSED LOT LINES	---
ADJACENT LOT LINES	---
PROPOSED EASEMENTS	---
PROPOSED SETBACKS	---
PROPOSED LIMIT OF GRADING	---
PROPOSED CONTOUR	---
EXISTING CONTOUR	---
PROPOSED 6" CURB & GUTTER	---
PROPOSED 6" CURB	---
PROPOSED HARDSCAPE	---
PROPOSED MASONRY RETAINING WALL	---
PROPOSED BMP	---
EXISTING WATER MAIN (SIZE PER PLAN)	---
EXISTING SEWER MAIN (SIZE PER PLAN)	---
EXISTING STORM DRAIN (SIZE PER PLAN)	---
EXISTING GAS MAIN	---
PROPOSED SEWER MANHOLE	---
PROPOSED 4" PVC STORM DRAIN	---
PROPOSED 18" RCP PRIVATE STORM DRAIN	---
PROPOSED 12" AREA DRAIN	---
PROPOSED 8" PRIVATE PVC SEWER MAIN	---
PROPOSED 8" PVC PUBLIC WATER MAIN	---

CONSTRUCTION NOTES

- EXISTING SURVEY MONUMENT TO BE PROTECTED IN PLACE; CORNER RECORD OR RECORD OF SURVEY TO BE FILED WITH THE COUNTY IF DISTURBED OR DESTROYED
- PROPOSED 6" PCC CURB PER SDRSD G-1 W/ CLASS II BASE
- PROPOSED 6" PCC CURB & GUTTER PER SDRSD G-2 W/ CLASS II BASE
- PROPOSED 5' WIDE, 4" THICK PCC SIDEWALK PER SDRSD G-7 W/ CLASS II BASE
- PROPOSED MASONRY RETAINING WALL PER SDRSD C-04
- PROPOSED WING-TYPE PCC HEADWALL WITH 4x4 RIP RAP ENERGY DISSIPATOR PER SDRSD D-34 & 40; ROCK CLASS = No. 2 BACKING T = 1.1 FT
- PROPOSED 36" X 36" BROOKS BOX OUTLET STRUCTURE; SEE BIOFILTRATION BASIN DETAIL SHEET 11
- PROPOSED MASONRY RETAINING WALL SYSTEM; DESIGN BY OTHERS
- PROPOSED 4" AC PAVEMENT OVER 6" CLASS II AB OR PER GEOTECH RECOMMENDATIONS
- PROPOSED PCC BROW DITCH PER SDRSD D-75, TYPE B
- PROPOSED PCC CROSS GUTTER PER SDRSD G-12
- SIGHT DISTANCE VIEW CORRIDOR PER CALTRANS HIGHWAY DESIGN MANUAL AND CITY OF OCEANSIDE STANDARDS
- PROPOSED MASONRY RETAINING WALL PER SDRSD C-03
- PROPOSED PCC PED RAMP PER SDRSD G-27
- PROPOSED PCC PED RAMP PER SDRSD G-29
- PROPOSED TREE WELL BMP (4' X 10'); SEE DETAIL SHEET 11
- PROPOSED ROLLED / MOUNTABLE PCC CURB AND GUTTER PER SDRSD G-04A W/ CLASS II BASE
- PROPOSED RIP RAP ENERGY DISSIPATOR PER SDRSD D-40; ROCK CLASS = 2 TON T=5.4'
- PROPOSED 6" PCC ROLLED CURB PER SDRSD G-04A W/ CLASS II BASE, MODIFIED WITHOUT GUTTER

CONSTRUCTION SITE NOTES

1. ALL UTILITIES SHOWN HEREON PER BEST AVAILABLE RECORDS. CONTRACTOR SHALL VERIFY EXACT HORIZONTAL AND VERTICAL LOCATION PRIOR TO CONSTRUCTION. CONTRACTOR SHALL NOTIFY ENGINEER OF RECORD OF DISCREPANCIES UPON DISCOVERY.

EXISTING EASEMENT NOTES

SEE SHEET 1 FOR PLOTTING AND SUMMARY OF EXISTING EASEMENTS

PROPOSED EASEMENT NOTES

SEE SHEET 2 FOR SUMMARY OF PROPOSED EASEMENTS

SEE SHEET 3 FOR CONTINUATION

PLAN VIEW - PRELIMINARY GRADING PLAN

SCALE: 1" = 20'



PASCO LARET SUITER & ASSOCIATES
 San Diego | Solana Beach | Orange County
 Phone 858.259.8212 | www.plsaengineering.com

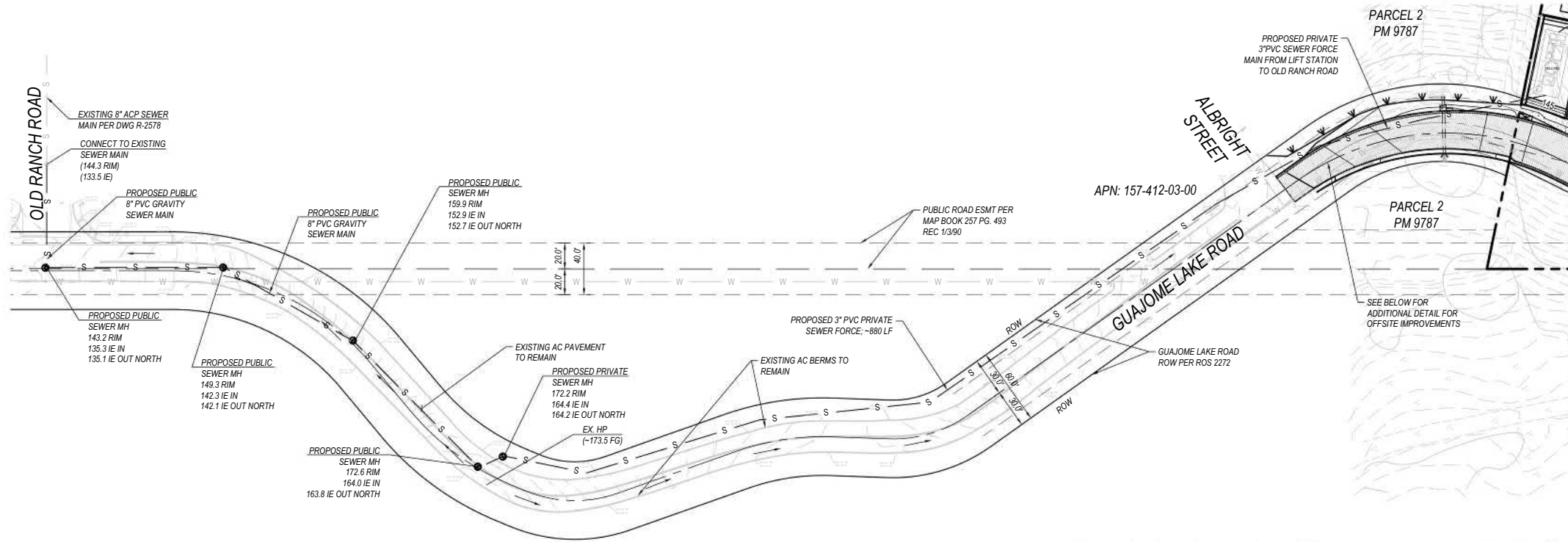

PLAN VIEW - OFFSITE IMPROVEMENTS PRIVATE SEWER FORCE MAIN AND PUBLIC GRAVITY MAIN

SCALE: 1" = 50'

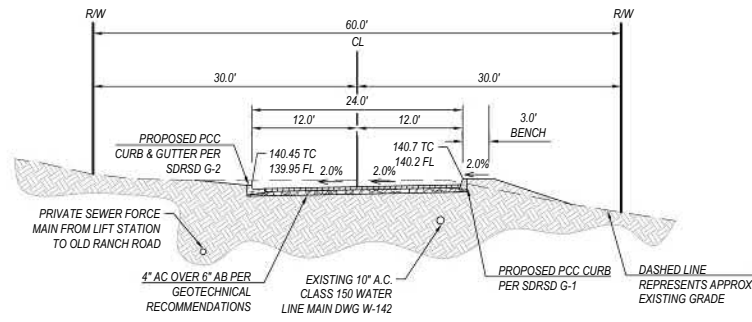

SECTION CUT X-X
NOT TO SCALE

OFFSITE IMPROVEMENT NOTE:

ULTIMATE OFFSITE PAVEMENT AND SURFACE IMPROVEMENTS ALONG GUAJOME LAKE ROAD SHOWN FOR REFERENCE ONLY. WITH ROADWAY WIDTH AND GEOMETRY PER CITY OF OCEANSIDE PUBLIC ROAD STANDARDS. ADDITIONAL PERMITTING FROM CITY OF OCEANSIDE AND/OR WILDLIFE AGENCIES AND PERMISSION TO GRADE FROM ADJACENT PROPERTY OWNER IS ANTICIPATED TO BE REQUIRED.

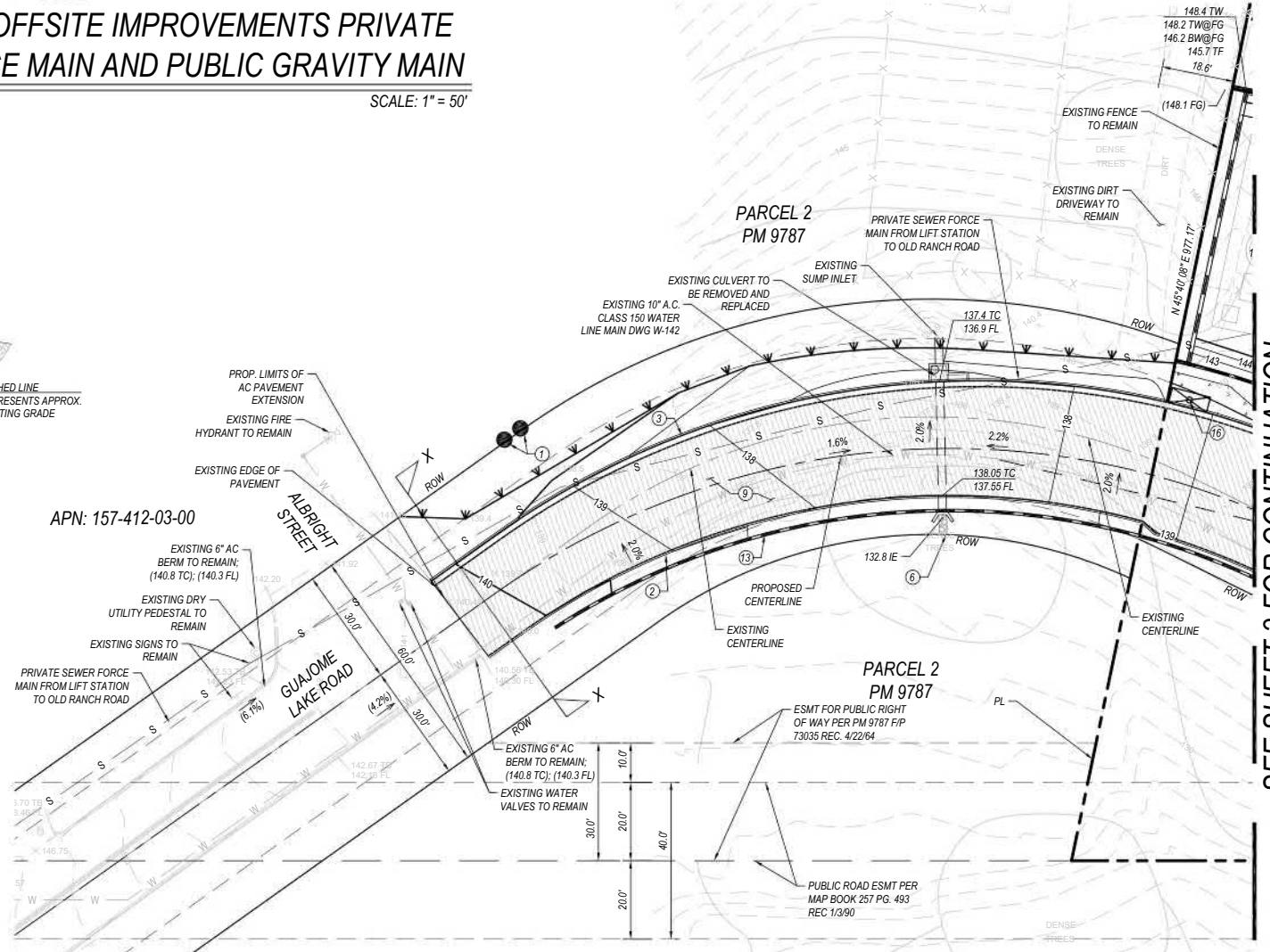

PLAN VIEW - PRELIMINARY GRADING PLAN

SCALE: 1" = 20'

LEGEND

PROPERTY LINE	---
RIGHT-OF-WAY	---
CENTERLINE OF ROAD	---
PROPOSED LOT LINES	---
ADJACENT LOT LINES	---
PROPOSED EASEMENTS	---
PROPOSED SETBACKS	---
PROPOSED LIMIT OF GRADING	---
PROPOSED CONTOUR	---
EXISTING CONTOUR	---
PROPOSED 6" CURB & GUTTER	---
PROPOSED 6" CURB	---
PROPOSED HARDSCAPE	---
PROPOSED MASONRY RETAINING WALL	---
PROPOSED BMP	---
EXISTING WATER MAIN (SIZE PER PLAN)	---
EXISTING SEWER MAIN (SIZE PER PLAN)	---
EXISTING STORM DRAIN (SIZE PER PLAN)	---
EXISTING GAS MAIN	---
PROPOSED SEWER MANHOLE	---
PROPOSED 4" PVC STORM DRAIN	---
PROPOSED 18" RCP PRIVATE STORM DRAIN	---
PROPOSED 12" AREA DRAIN	---
PROPOSED 8" PRIVATE PVC SEWER MAIN	---
PROPOSED 8" PVC PUBLIC WATER MAIN	---

CONSTRUCTION NOTES

- EXISTING SURVEY MONUMENT TO BE PROTECTED IN PLACE; CORNER RECORD OR RECORD OF SURVEY TO BE FILED WITH THE COUNTY IF DISTURBED OR DESTROYED
- PROPOSED 6" PCC CURB PER SDRSD G-1 W/ CLASS II BASE
- PROPOSED 6" PCC CURB & GUTTER PER SDRSD G-2 W/ CLASS II BASE
- PROPOSED 5' WIDE, 4" THICK PCC SIDEWALK PER SDRSD G-7 W/ CLASS II BASE
- PROPOSED MASONRY RETAINING WALL PER SDRSD C-04
- PROPOSED WING-TYPE PCC HEADWALL WITH 4x4 RIP RAP ENERGY DISSIPATOR PER SDRSD D-34 & 40; ROCK CLASS = No. 2 BACKING T = 1.1 FT
- PROPOSED 36" X 36" BROOKS BOX OUTLET STRUCTURE; SEE BIOFILTRATION BASIN DETAIL SHEET 11
- PROPOSED MASONRY RETAINING WALL SYSTEM; DESIGN BY OTHERS
- PROPOSED 4" AC PAVEMENT OVER 6" CLASS II AB OR PER GEOTECH RECOMMENDATIONS
- PROPOSED PCC BROW DITCH PER SDRSD D-75, TYPE B
- PROPOSED PCC CROSS GUTTER PER SDRSD G-12
- SIGHT DISTANCE VIEW CORRIDOR PER CALTRANS HIGHWAY DESIGN MANUAL AND CITY OF OCEANSIDE STANDARDS
- PROPOSED MASONRY RETAINING WALL PER SDRSD C-03
- PROPOSED PCC PED RAMP PER SDRSD G-27
- PROPOSED PCC PED RAMP PER SDRSD G-29
- PROPOSED TREE WELL BMP (4' X 10'); SEE DETAIL SHEET 11
- PROPOSED ROLLED / MOUNTABLE PCC CURB AND GUTTER PER SDRSD G-04A W/ CLASS II BASE
- PROPOSED RIP RAP ENERGY DISSIPATOR PER SDRSD D-40; ROCK CLASS = 2 TON T=5.4'
- PROPOSED 6" PCC ROLLED CURB PER SDRSD G-04A W/ CLASS II BASE, MODIFIED WITHOUT GUTTER

CONSTRUCTION SITE NOTES

1. ALL UTILITIES SHOWN HEREON PER BEST AVAILABLE RECORDS. CONTRACTOR SHALL VERIFY EXACT HORIZONTAL AND VERTICAL LOCATION PRIOR TO CONSTRUCTION. CONTRACTOR SHALL NOTIFY ENGINEER OF RECORD OF DISCREPANCIES UPON DISCOVERY.

EXISTING EASEMENT NOTES

SEE SHEET 1 FOR PLOTTING AND SUMMARY OF EXISTING EASEMENTS

PROPOSED EASEMENT NOTES

SEE SHEET 2 FOR SUMMARY OF PROPOSED EASEMENTS

SEE SHEET 3 FOR CONTINUATION

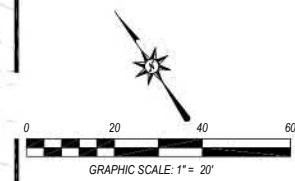

PASCO LARET SUITER & ASSOCIATES
San Diego | Solana Beach | Orange County
Phone 858.259.8212 | www.plsaengineering.com

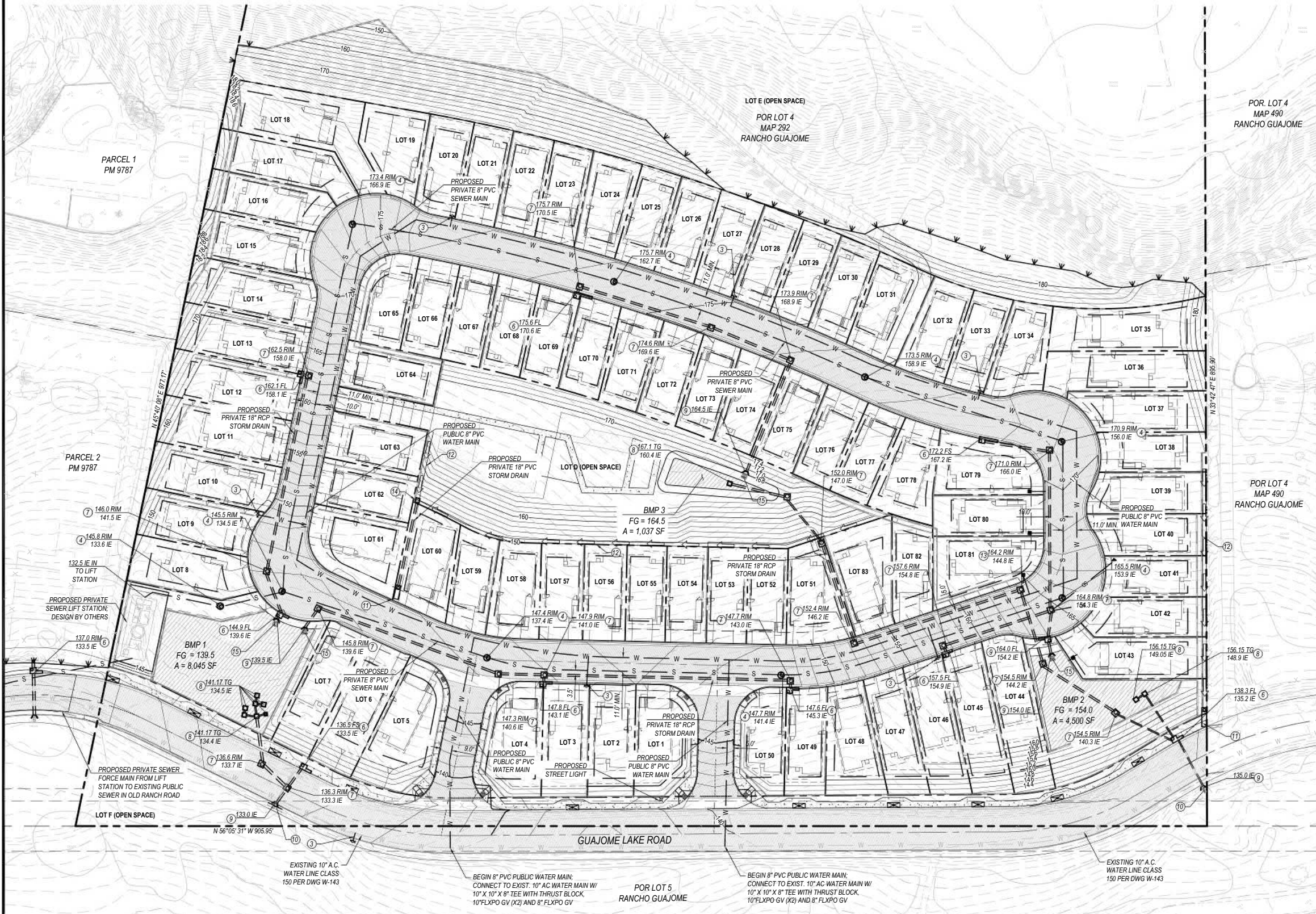

LEGEND

PROPERTY LINE	---
RIGHT-OF-WAY	====
CENTERLINE OF ROAD	—+—+—+—+—+—
PROPOSED LOT LINES	----
ADJACENT LOT LINES	----
PROPOSED EASEMENTS	----
PROPOSED SETBACKS	----
PROPOSED LIMIT OF GRADING	—W—W—W—
PROPOSED CONTOUR	—140—
EXISTING CONTOUR	—140—
PROPOSED 6" CURB & GUTTER	====
PROPOSED 6" CURB	====
PROPOSED HARDSCAPE	====
PROPOSED MASONRY RETAINING WALL	====
PROPOSED BMP	====
EXISTING WATER MAIN (SIZE PER PLAN)	—W—W—
EXISTING SEWER MAIN (SIZE PER PLAN)	—S—S—
EXISTING STORM DRAIN (SIZE PER PLAN)	—SD—SD—
EXISTING GAS MAIN	—G—G—
PROPOSED SEWER MANHOLE	⊙
PROPOSED 4" PVC PVT STORM DRAIN	—SD—SD—
PROPOSED 18" RCP PRIVATE STORM DRAIN	—SD—SD—
PROPOSED 12" AREA DRAIN	□
PROPOSED 8" PRIVATE SEWER MAIN	—S—S—
PROPOSED 8" PUBLIC WATER MAIN	—W—W—

UTILITY CONSTRUCTION NOTES

- PROPOSED 1" WATER SERVICE AND METER PER CITY OF OCEANSIDE STD W
- PROPOSED 4" PVC SEWER LATERAL PER SDRSD SS-01
- PROPOSED FIRE HYDRANT ASSEMBLY PER CITY OF OCEANSIDE STD. W-01
- PROPOSED 60" SEWER MANHOLE PER SDRSD SM-01
- PROPOSED 18" PRIVATE RCP STORM DRAIN (1350-D)
- PROPOSED TYPE B CURB INLET PER SDRSD D-02
- PROPOSED TYPE A-4 STORM DRAIN CLEANOUT PER SDRSD D-09
- PROPOSED 36" X 36" BROOKS BOX OUTLET STRUCTURE. SEE BIOFILTRATION BASIN DETAIL SHEET 11 FOR LOW-FLOW ORIFICE INFORMATION
- PROPOSED 4" PVC SEWER LATERAL PER SDRSD SS-01
- PROPOSED WING-TYPE HEADWALL PER SDRSD D-34
- PROPOSED 4" X 4" RIP RAP ENERGY DISSIPATER PER SDRSD D-40; ROCK CLASS = No. 2 BACKING T=1.1FT
- PROPOSED CURB OUTLET PER SDRSD D-25 (1350-D)
- PROPOSED PCC DRAINAGE DITCH PER SDRSD D-75, TYPE B
- PROPOSED TYPE B-5 STORM DRAIN CLEANOUT PER SDRSD D-10
- PROPOSED TYPE-F CATCH BASIN PER SDRSD D-07
- PROPOSED 4" X 4" RIP RAP ENERGY DISSIPATER PER SDRSD D-40; ROCK CLASS = 2 TON BACKING T=5.4'

UTILITY SITE NOTES

1. ALL UTILITIES SHOWN HEREON PER BEST AVAILABLE RECORDS. CONTRACTOR SHALL VERIFY EXACT HORIZONTAL AND VERTICAL LOCATION PRIOR TO CONSTRUCTION. CONTRACTOR SHALL NOTIFY ENGINEER OF RECORD OF DISCREPANCIES UPON DISCOVERY.

PLAN VIEW - PRELIMINARY UTILITIES EXHIBIT
SCALE: 1" = 40'

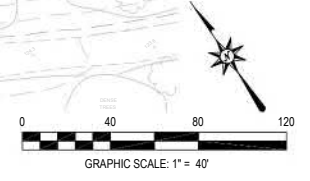

PASCO LARET SUITER & ASSOCIATES
San Diego | Solana Beach | Orange County
Phone 858.259.8212 | www.plsaengineering.com

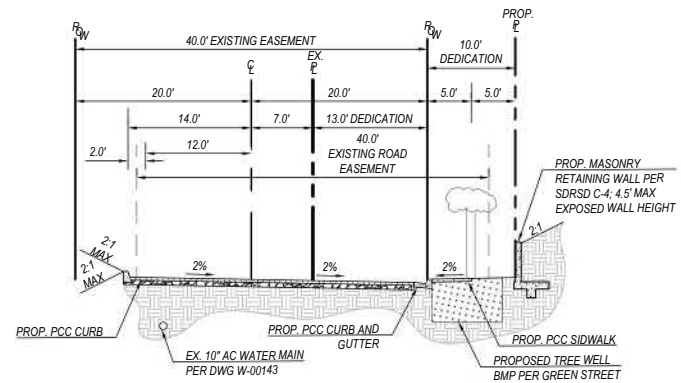

TYPICAL SECTION - GUAJOME LAKE ROAD
SCALE: NTS

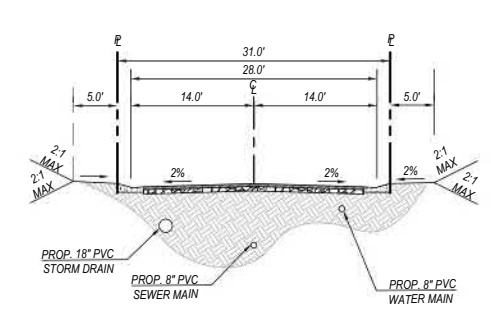

TYPICAL SECTION - PRIVATE ROAD NORTH
SCALE: NTS

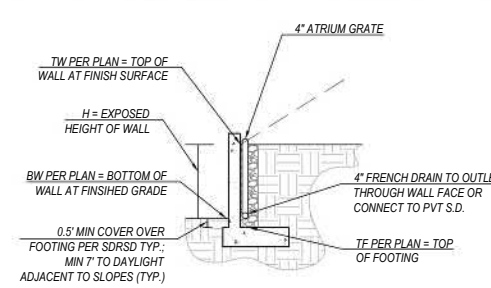

TYPICAL DETAIL - RETAINING WALL
SCALE: NTS

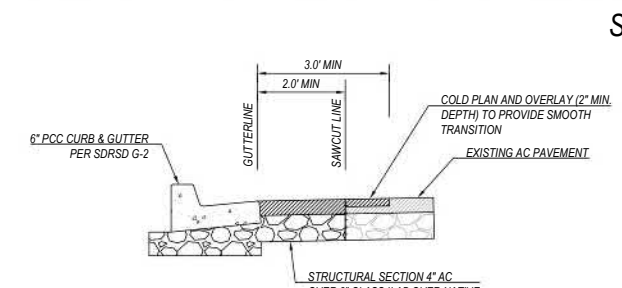

TYPICAL DETAIL - AC PAVEMENT SAWCUT
SCALE: NTS

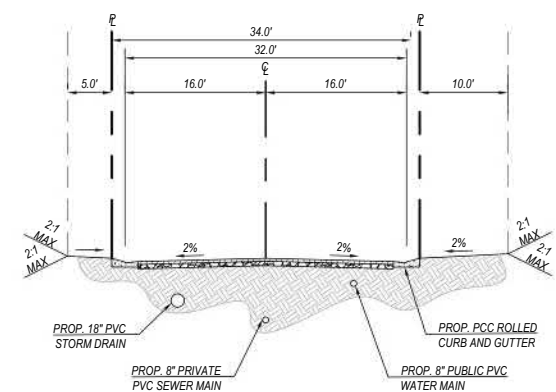

TYPICAL SECTION - PRIVATE ROAD SOUTH
SCALE: NTS

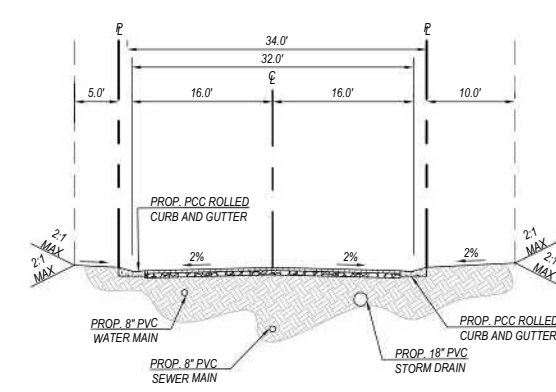

TYPICAL SECTION - PRIVATE ROAD WEST
SCALE: NTS

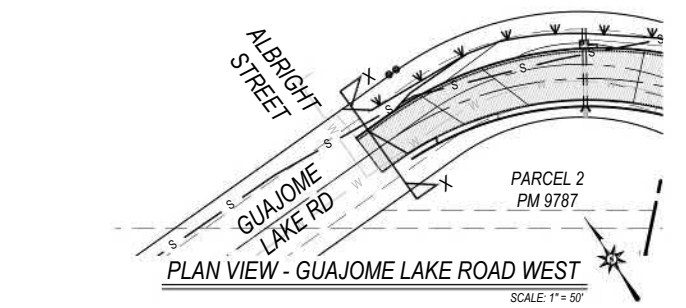

PLAN VIEW - GUAJOME LAKE ROAD WEST
SCALE: 1" = 50'

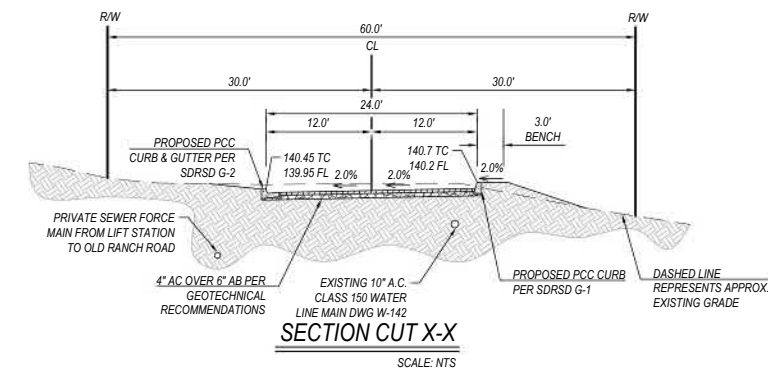

SECTION CUT X-X
SCALE: NTS

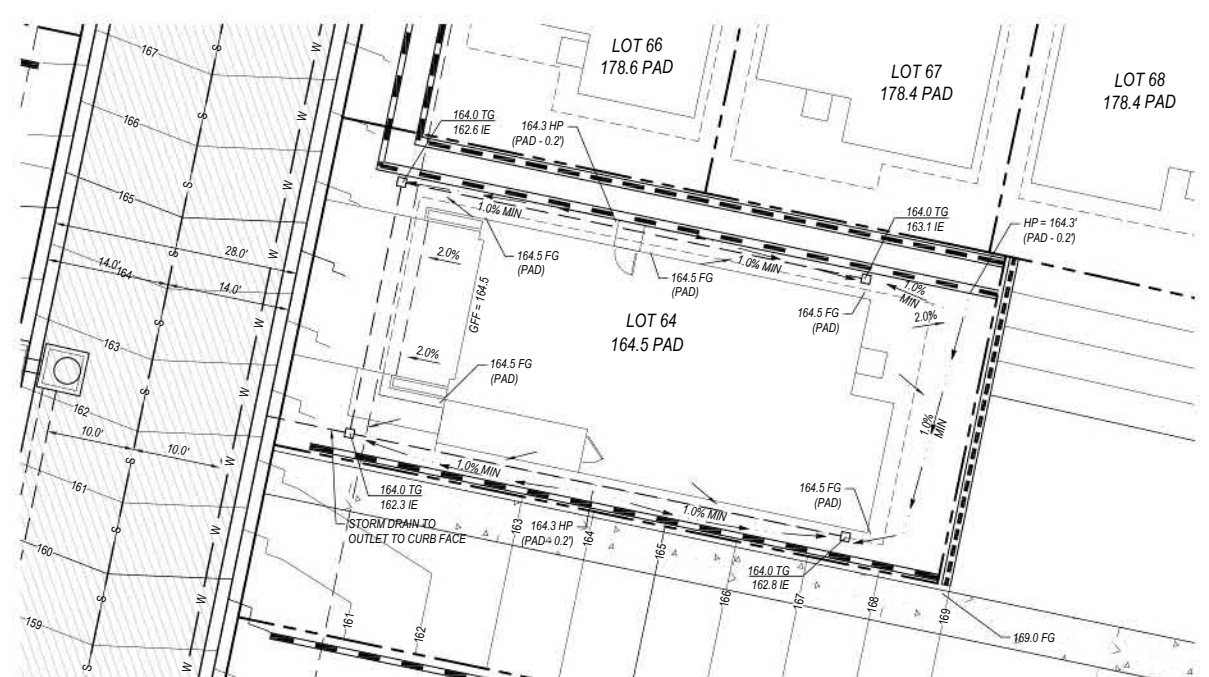

TYPICAL DETAIL - LOT DRAINAGE FOR PRELIMINARY PRECISE GRADING
SCALE: 1" = 10'

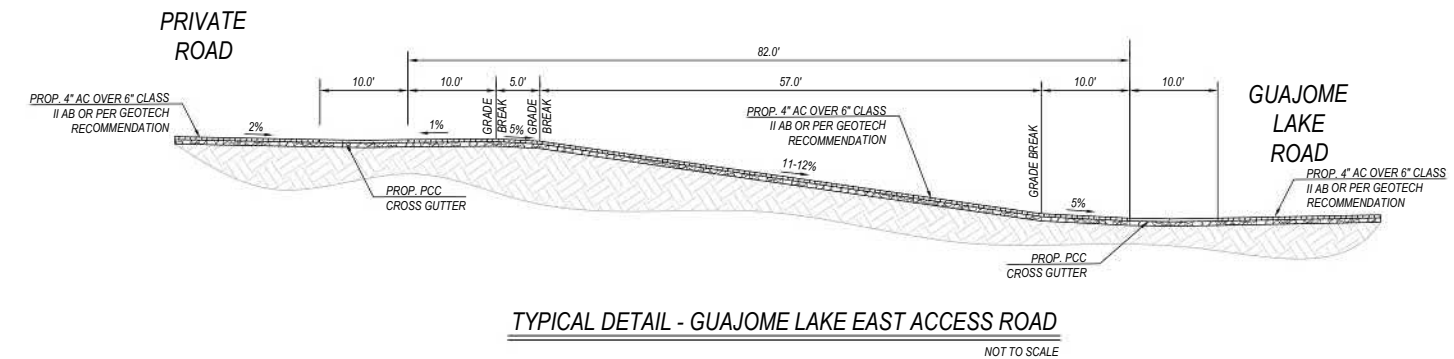

TYPICAL DETAIL - GUAJOME LAKE EAST ACCESS ROAD
NOT TO SCALE

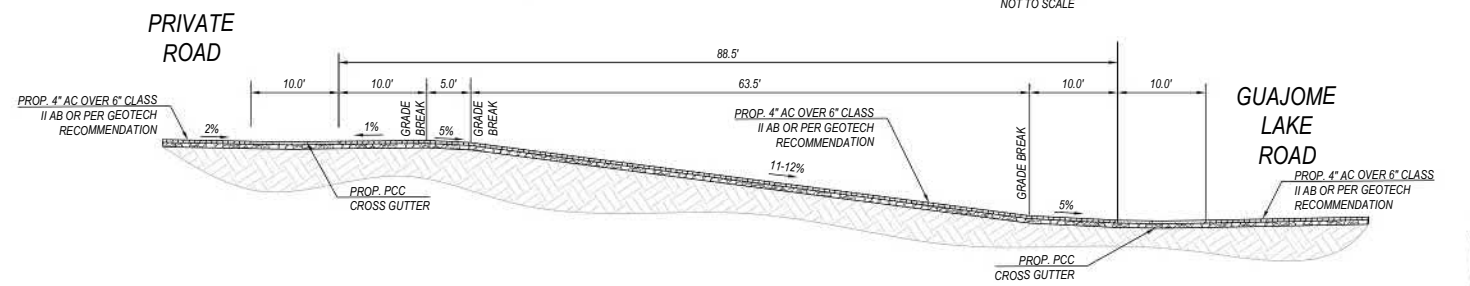

TYPICAL DETAIL - GUAJOME LAKE WEST ACCESS ROAD
NOT TO SCALE



PASCO LARET SUITER & ASSOCIATES
San Diego | Solana Beach | Orange County
Phone 858.259.8212 | www.plsaengineering.com

**ATTACHMENT 5
Drainage Report**

This is the cover sheet for Attachment 5.



PRELIMINARY HYDROLOGY STUDY

FOR

**DISCRETIONARY APPROVAL – DEVELOPMENT PLAN,
TENTATIVE MAP, DENSITY BONUS**

(UNASSIGNED) GUAJOME LAKE ROAD, OCEANSIDE CA

PLANNING CASE NO: T22-00004 / D22-00009 / DB22-00005

CITY OF OCEANSIDE, CA

PREPARED FOR:

RINCON REAL ESTATE GROUP
5315 AVENIDA ENCINAS, SUITE 200
CARLSBAD, CA 92008
PH: (949) 637-3254

PREPARED BY:

PASCO LARET SUITER & ASSOCIATES, INC.
1911 SAN DIEGO AVENUE, SUITE 100
SAN DIEGO, CA 92110
PH: (858) 259-8212

Prepared: June 2022
Revised: August 2024

PRELIMINARY

TYLER G. LAWSON, RCE 80356

DATE

TABLE OF CONTENTS

	<u>SECTION</u>
Executive Summary	1.0
Introduction	1.1
Existing Conditions	1.2
Proposed Project	1.3
Conclusions	1.4
References	1.5
Methodology	2.0
Introduction	2.1
County of San Diego Criteria	2.2
City of Oceanside Standards	2.3
Runoff Coefficient Determination	2.4
AES Rational Method Computer Model	2.5
Hydrology & Hydraulic Model Output	3.0
Pre-Developed Hydrologic Model Output (100-Year Event)	3.1
Post-Developed Hydrologic Model Output (100-Year Event)	3.2
Detention Analysis (100-Year Event)	3.3
Hydromodification Analysis	3.4
Storm Water Pollutant Control	3.5
Appendix	4.0
Appendix A: Hydrology Support Material	
Appendix B: Storm Water Pollutant Control and Detention Calculations	

1.0 EXECUTIVE SUMMARY

1.1 Introduction

This Preliminary Hydrology Study for the proposed development at an assigned address along Guajome Lake Road has been prepared to analyze the hydrologic and hydraulic characteristics of the existing and proposed project site. This report intends to present both the methodology and the calculations used for determining the runoff from the project site in both the pre-developed (existing) conditions and the post-developed (proposed) conditions produced by the 100-year, 6-hour design storm event. For hydromodification management and compliance including analysis up to the 10-year, 6-hour storm event, refer to the project Storm Water Quality Management Plan (SWQMP) prepared by Pasco, Laret, Suiter & Associates under separate cover.

1.2 Existing Conditions

The subject property is located just east of Guajome Lake Road, south of the intersection of with Albright Street in the City of Oceanside. The site is bordered directly to the north by the existing single-family residences off Albright Street, to the east by existing single-family residences located along Seattle Slew Way, and to the south by a single-family lot located at 2837 Guajome Lake Road. West of Guajome Lake Road immediately adjacent the subject property is Guajome Regional Park and the Guajome County Park Willow Trail.

The project site has a General Plan Land Use designation of Single-Family Detached Residential (SFD-R) and a Zoning Designation of Single-Family Residential, Scenic Park Overlay, and Equestrian Overlay (RS-SP-EQ). The site itself is a primarily vacant, undeveloped parcel that consists of a dirt driveway leading to two existing structures located further east within the property. An existing ridgeline near the center of the site separates a naturally sloping portion of the lot from existing Coastal Sage Scrub and other habitat / riparian areas along with a non-wetland water ephemeral stream that ultimately empties into Guajome Lake. The site is located within the Mission Hydrologic Sub-Area of the Lower San Luis Hydrologic Area within the San Luis Rey Watershed (903.11).

The existing site is comprised of approximately 16.79 gross acres. The site contains a large amount of terrain with roughly 40-50 feet of elevation difference from the ridgeline located in the center of the property down to Guajome Lake Road to the west. Additionally, another roughly 50 feet of elevation difference exists from the ridgeline to the ephemeral stream to the east. Runoff through the site primarily flows via sheet flow methods to three different discharge locations leaving the property. A local high point exists adjacent to the site along Guajome Lake Road, directing runoff to the north and south. As such, one main point of discharge from Basin EX-1 exists in the southwest corner of the site at a local low spot on Guajome Lake Road, and another from Basin EX-2 in the southeast corner of the site. Local sump inlets on the east side of the road feed culverts that discharge west of Guajome Lake Road to continue downstream. Basin EX-1 outlet continues northwest and appears to outlet to Guajome Lake. Basin EX-2 continues southeast towards an existing pond east of Ozark Road. Separately, Basin EX-3 consists of a portion of the proposed

project disturbance east of the ridgeline, that continues to drain to the east and the existing stream. This stream appears to continue northwest and outlet to Guajome Lake within Guajome Regional Park.

A review of the site topography offsite and at the property edge conditions revealed that the existing improvements to the north prevent additional runoff from entering the site from that direction. Additionally, an existing driveway serving 2837 Guajome Lake Road and the conditions along the southern property boundary prevent additional drainage from entering the subject property offsite. To the west, Guajome Lake Road is located at the bottom of the site topography and downstream of the analyzed drainage basins. Lastly, to the east, the existing single-family residences along Seattle Slew Way are located downstream of the ridgeline separating drainage running east or west on the property, and do not drain onto the subject property. For the purpose of the analysis, the limits were contained to the proposed disturbed areas of the site only in order to compare the impact of the proposed development to the existing conditions.

Per the Web Soil Survey application available through the United States Department of Agriculture, the area is generally categorized to have majority group D soils within the proposed disturbed limits. A portion of the site is also mapped as Type A, but is located within the riparian areas delineated by the project biologist and outside the proposed disturbed limits of work. Thus, Type D soils are assumed for this analysis for use in determining runoff coefficients for use in the Rational Method calculations for the portions onsite. Based upon soil type and the amount of existing impervious area onsite, a runoff coefficient of 0.35 was calculated for the existing site using the methodology described in section 3.1.2 of the San Diego County Hydrology Manual and the formula provided therein. This runoff coefficient was applied to each drainage basin for use in determining peak runoff leaving the site from the property discharge location. Using the Rational Method Procedure outlined in the San Diego County Hydrology Manual, a peak flow rate and time of concentration was calculated for the analyzed basin for the 100-year, 6-hour storm event. Table 1 below summarizes the results of the Rational Method calculations.

EXISTING DRAINAGE FLOWS				
DRAINAGE AREA	DRAINAGE AREA (ACRES)	Q ₁₀₀ (CFS)	I ₁₀₀ (IN/HR)	DISCHARGE LOCATION
EX-1	4.15 Ac	7.77	5.35	POC-1
EX-2	4.34 Ac	8.35	5.5	POC-2
EX-3	1.92 Ac	5.13	7.64	POC-3

Table 1. Existing Condition Peak Drainage Flow Rates

Table 1 above lists the peak flow rates for the project site in the existing condition for the respective rainfall events. The peak flow rate for the 100-year, 6-hour storm for Basin EX-

1 was determined to be 7.77 cfs with a time of concentration of 8.7 minutes, discharging from the northwest corner of the site, 8.35 cfs with a time of concentration of 8.3 minutes for Basin EX-2 discharging from the southwest corner of the site, and 5.13 cfs with a time of concentration of 5.0 minutes discharging from the northeast corner of the site. Refer to pre-development hydrology calculations included in Section 3.1 of this report for a detailed analysis of the existing drainage basin, as well as a pre-development hydrology node map included in the appendix of this report for pre-development drainage basin delineation and discharge locations leaving the subject property.

1.3 Proposed Project

The proposed project includes the mass grading of the proposed property, along with the construction of 83x new single-family lots and residences and 5x separate lettered lots consisting of active and passive open space as well as storm water treatment. Additionally, the project proposes to install backbone utility infrastructure consisting of storm drain, public water main, and sewer force main and lift station to serve the new residences. Various surface, grading, and utility improvements typical of this type of construction are also proposed. The proposed pad elevations vary from 150.0 in the southwest corner of the site to 180.0 in the northeast corner of the site. Additional information can be seen on the project Preliminary Grading Plan submitted as part of the Tentative Map, Density Bonus and Development Plan application under separate cover.

The proposed private lots will primarily drain from the rear of each property away from the building and out to the front of each lot by a combination of sheet flow methods / swale grading and private storm drain piping. A high point exists at the northwest corner of the site within the private road, which is then sloped to the south and west from there. Proposed storm drain curb inlets will intercept and capture curb and gutter flow, directing runoff to the storm drain backbone system. Lots that cannot feasibly drain to the private road and storm drain inlets will tie directly into the buried storm drain backbone from their respective lot. From there, storm drain will convey drainage to one (1) of three (3) different biofiltration basin BMP's for treatment, hydromodification management and flood control mitigation of the 100-year, 6-hour storm event peak flow rate. All proposed hardscape within the developed area of the project will be captured and routed to the BMP's. From there, an outlet pipe will then convey treated and detained runoff to the appropriate points of discharge from the subject property.

As in the existing condition, the project site will not accept any offsite runoff from the adjacent properties to the north, south, east, or west. Similar to the existing condition, the analyzed watershed can be broken down into three major drainage basins with three separate discharge locations from the site. The majority of the site's disturbed area is split between basins PR-1 and PR-2. Basin PR-1 is approximately 5.28 acres in size and will continue to discharge from POC-1 at the southwest corner of the site after being piped under Guajome Lake Road. As mentioned previously in this report, this outlet location continues northwest and appears to outlet to Guajome Lake. Basin PR-2 is approximately 4.76 acres in size, with portions being routed to two (2) different biofiltration basins. Discharge leaving from both biofiltration basins will continue to discharge to POC-2 at the

southeast corner of the site, also being piped under Guajome Lake Road. This will continue southwest toward an existing pond east of Ozark Road. These discharge locations both follow existing drainage patterns once leaving the subject property and continuing downstream. Basin PR-3 comprises the remaining area of the site included in this analysis that will be graded but will continue flowing north to the Basin EX-3 discharge location as in the existing condition. These portions will reach the existing ephemeral stream and continue to be conveyed northwest to Guajome Lake.

Based on the proposed land use and soil type of the subject property, runoff coefficients for this site were determined using Table 3-1 Runoff Coefficients for Urban Areas of the San Diego County Hydrology Manual. Refer to section 3.2 of this report, as well as the post-development hydrology map included in Appendix A, for additional analysis and a summary of runoff coefficients used for the proposed development. Using the Rational Method Procedure outlined in the San Diego County Hydrology Manual, a peak flow rate and time of concentration were calculated for the 100-year, 6-hour storm event for each of the drainage basins in the proposed condition. Table 2 below summarizes the results of the Rational Method calculations.

PROPOSED DRAINAGE FLOWS				
DRAINAGE AREA	DRAINAGE AREA (ACRES)	Q ₁₀₀ (CFS)	I ₁₀₀ (IN/HR)	DISCHARGE LOCATION
PR-1.1	4.70 Ac	19.54	6.03	BMP-1
PR-1.2	0.58 Ac	2.65	5.95	POC-1
PR-1 (Tot)	5.28 Ac	21.90	-	POC-1
PR-2.1	2.85 Ac	12.29	5.87	BMP-2
PR-2.2	1.07 Ac	3.75	5.14	BMP-3
PR-2.3	0.84 Ac	3.41	5.80	POC-2
PR-2 (Tot)	4.76 Ac	19.34	-	POC-2
PR-3	0.38 Ac	1.01	7.64	POC-3

Table 2. Proposed Condition Peak Drainage Flow Rates

The results above show the undetained peak flows leaving the subject property at the three (3) main points of discharge in the proposed condition, in order to compare to pre-developed conditions. Refer to Section 3.3 of this report for a full discussion of the routing analysis performed for the project in order to size the onsite detention facilities to mitigate peak flows to pre-project conditions. Refer to post-development hydrology calculations included in Section 3.2 of this report for detailed analyses of the proposed drainage basins

as well as a post-development hydrology node map included in Appendix A of this report for post-development drainage delineation and discharge locations.

COMPARISON DRAINAGE FLOWS			
DRAINAGE AREA	DRAINAGE AREA (ACRES)	Q ₁₀₀ (CFS)	I ₁₀₀ (IN/HR)
EX-1	4.15 Ac	7.77	5.35
PR-1	5.28 Ac	21.90	-
EX-2	4.49 Ac	8.35	5.5
PR-2	4.76 Ac	19.34	-
EX-3	1.94 Ac	5.13	7.64
PR-3	0.38 Ac	1.01	7.64

Table 3. Comparison Peak Drainage Flow Rates

As this section of the report only serves to analyze the total, unmitigated peak runoff generated from the proposed project, refer to Section 3.3 of this report for a discussion of the detention components of the site. This analysis takes into account the proposed flood control mitigation facilities proposed onsite, which include the two biofiltration basin BMP's. The results of the detention analysis provide a resultant, mitigated peak runoff leaving the site in addition to the detained time to peak (see Appendix B for results of the dynamic detention analysis performed using HydroCAD-10 software).

In an effort to comply with the City of Oceanside's Stormwater standards, all runoff generated onsite will be conveyed to an onsite biofiltration facility for treatment and pollutant removal. For a discussion regarding hydromodification management requirements and compliance, refer to the project Storm Water Quality Management Plan (SWQMP) under separate cover. In an effort to comply with the City of Oceanside's storm water standards for all development projects, the project site will implement source control and site design BMP's in addition to the proposed biofiltration treatment control BMP's where feasible and applicable in accordance with the City of Oceanside's BMP Design Manual, February 2016 edition. Proposed impervious area and soil compaction are minimized to the greatest extent feasible, and dispersion is promoted as well. Partial infiltration and evapotranspiration in landscaped areas will assist in slowing peak discharges and in reducing total volume generated during storm events, while in addition serving to comply with volume retention requirements of the project. The onsite landscaped areas will assist to remove sediment and particulate-bound pollutants from storm water prior to leaving the project site.

1.4 Conclusions

Based upon the hydrology calculations performed for the project site, there is an increase in unmitigated peak runoff in the post-developed condition compared to the existing condition due to the increase in proposed site hardscape from the currently vacant condition. For a discussion on the detention analysis performed for the project site, refer to Section 3.3 below as well as the Appendix of this report. Based on the analysis included in this report, the proposed onsite detention facilities accommodate the increase in peak runoff generated in the proposed condition, mitigating peak flows to below pre-developed conditions at the appropriate points of discharge. The site has been designed and graded in a way to minimize earthwork to the greatest extent feasible and maintain historic drainage patterns. Water leaving the subject property will continue to do so from the same points of discharge as in the existing condition. Thus, water will not be diverted away from existing drainage patterns, and the proposed development and resulting peak runoff will not have an adverse effect on the downstream watershed and existing infrastructure.

1.5 References

“San Diego County Hydrology Manual”, revised June 2003, County of San Diego, Department of Public Works, Flood Control Section.

“San Diego County Hydraulic Design Manual”, revised September 2014, County of San Diego, Department of Public Works, Flood Control Section

“Master Plan of Drainage, Update 2013”, revised October 2013, City of Oceanside, prepared by Tory R. Walker Engineering, Inc.

“City of Oceanside BMP Design Manual for Permanent Site Design, Storm Water Treatment and Hydromodification Management”, revised February 2016, City of Oceanside, prepared by GHD

Soil Survey Staff, Natural Resources Conservation Service, United States Department of Agriculture. Web Soil Survey. Available online at <http://websoilsurvey.nrcs.usda.gov>.

2.0 METHODOLOGY

2.1 Introduction

The hydrologic model used to perform the hydrologic analysis presented in this report utilizes the Rational Method (RM) equation, $Q = CIA$. The RM formula estimates the peak rate of runoff based on the variables of area, runoff coefficient, and rainfall intensity. The rainfall intensity (I) is equal to:

$$I = 7.44 \times P_6 \times D^{-0.645}$$

Where:

I = Intensity (in/hr)
 P_6 = 6-hour precipitation (inches)
 D = duration (minutes – use T_c)

Using the Time of Concentration (T_c), which is the time required for a given element of water that originates at the most remote point of the basin being analyzed to reach the point at which the runoff from the basin is being analyzed. The RM equation determines the storm water runoff rate (Q) for a given basin in terms of flow (typically in cubic feet per second (cfs) but sometimes as gallons per minute (gpm)). The RM equation is as follows:

$$Q = CIA$$

Where:

Q = flow (in cfs)
 C = runoff coefficient, ratio of rainfall that produces storm water runoff (runoff vs. infiltration/evaporation/absorption/etc)
 I = average rainfall intensity for a duration equal to the T_c for the area, in inches per hour.
 A = drainage area contributing to the basin in acres.

The RM equation assumes that the storm event being analyzed delivers precipitation to the entire basin uniformly, and therefore the peak discharge rate will occur when a raindrop that falls at the most remote portion of the basin arrives at the point of analysis. The RM also assumes that the fraction of rainfall that becomes runoff or the runoff coefficient C is not affected by the storm intensity, I, or the precipitation zone number.

2.2 County of San Diego Criteria

As defined by the County Hydrology Manual dated June 2003, the rational method is the preferred equation for determining the hydrologic characteristics of basins up to approximately one square mile in size. The County of San Diego has developed its own tables, nomographs, and methodologies for analyzing storm water runoff for areas within the county. The County has also developed precipitation isopluvial contour maps that show even lines of rainfall anticipated from a given storm event (i.e. 100-year, 6-hour storm).

One of the variables of the RM equation is the runoff coefficient, C . The runoff coefficient is dependent only upon land use and soil type and the County of San Diego has developed a table of Runoff Coefficients for Urban Areas to be applied to basin located within the County of San Diego. The table categorizes the land use, the associated development density (dwelling units per acre) and the percentage of impervious area. Each of the categories listed has an associated runoff coefficient, C , for each soil type class.

The County has also illustrated in detail the methodology for determining the time of concentration, in particular the initial time of concentration. The County has adopted the Federal Aviation Agency's (FAA) overland time of flow equation. This equation essentially limits the flow path length for the initial time of concentration to lengths under 100 feet, and is dependent on land use and slope.

2.3 City of Oceanside Standards

The City of Oceanside has additional information, overview, analysis, and findings for watersheds located within the City which are outlined in the Master Plan of Drainage, 2013 Update. Please refer to this manual for reference and further details.

2.4 Runoff Coefficient Determination

As stated in section 2.2, the runoff coefficient is dependent only upon land use and soil type and the County of San Diego has developed a table of Runoff Coefficients for Urban Areas to be applied to basin located within the County of San Diego. The table, included at the end of this section, categorizes the land use, the associated development density (dwelling units per acre) and the percentage of impervious area.

2.5 AES Rational Method Computer Model

The Rational Method computer program developed by Advanced Engineering Software (AES) satisfies the County of San Diego design criteria, therefore it is the computer model used for this study. The AES hydrologic model is capable of creating independent node-link models of each interior drainage basin and linking these sub-models together at confluence points to determine peak flow rates. The program utilizes base information input by the user to perform calculations for up to 15 hydrologic processes. The required base information includes drainage basin area, storm water facility locations and sizes, land

uses, flow patterns, and topographic elevations. The hydrologic conditions were analyzed in accordance with the 2003 County of San Diego Hydrology Manual criteria as follows:

Design Storm	100-year, 6-hour
100-year, 6-hour Precipitation	2.9 inches
Rainfall Intensity	Based on the 2003 County of San Diego Hydrology Manual criteria
Runoff Coefficient	Weighted Runoff Coefficients per Section 3.1, 3.2 of this report and Table 3-2 of SDHDM

2.5.1 AES Computer Model Code Information

- 0: Enter Comment
- 2: Initial Subarea Analysis
- 3: Pipe/Box/Culvert Travel Time
- 5: Open Channel Travel Time
- 7: User-Specified hydrology data at Node
- 8: Addition of sub-area runoff to Main Stream
- 10: Copy Main Stream data onto a Memory Bank
- 11: Confluence Memory Bank data with Main Stream
- 13: Clear the Main Stream

3.0 HYDROLOGY MODEL OUTPUT

3.1 Pre-Developed Hydrologic Model Output (100 Year Event)

Pre-Development:

$$Q = CIA$$

$$P_{100} = 2.9 \text{ in}$$

*Rational Method Equation
*100-Year, 6-Hour Rainfall Precipitation

Total Disturbed Area

$$\text{Total Area} = 453,625 \text{ sf} \rightarrow 10.41 \text{ Acres}$$

$$\text{Impervious Area} = 700 \text{ sf} \rightarrow 0.02 \text{ Ac}$$

$$\text{Pervious Area} = 452,925 \text{ sf} \rightarrow 10.39 \text{ Acres}$$

Cn, Weighted Runoff Coefficient,

- 0.35, Cn value for natural ground, Type D Soils
*Per San Diego County Hydrology Manual (SDCHM) Section 3.1.2
- 0.90, Cn value for developed/impervious surface
*Per SDCHM Section 3.1.2

$$Cn = \frac{0.35 \times 452,925 + .9 \times 700 \text{ sf}}{453,625 \text{ sf}} = 0.35$$

Basin EX-1

$$\text{Total Area} = 180,901 \text{ sf} \rightarrow 4.15 \text{ Acres}$$

Initial Slope ~10%, Land Use = Natural
Ti = 6.9 mins

*Table 3-2 per SDCHM

$$T_t = \{[11.9 \times (389 \text{ ft} / 5,280 \text{ ft/mile})^3] / 41.4 \text{ ft}\}^{0.385} = .030 \text{ hours}$$

$$= .030 \text{ hours} \times 60 \text{ min} / \text{hr} = 1.8 \text{ min}$$

$$T_c = 6.9 + 1.8 = 8.7 \text{ min}$$

$$T_c = \underline{\underline{8.7 \text{ min}}}$$

$$P_6 = 2.9$$

$$I = 7.44 \times P_6 \times D^{-0.645}$$

$$I = 7.44 \times 2.9 \times 8.7^{-0.645} \approx \underline{\underline{5.35 \text{ in/hr}}}$$

$$Q_{100} = C \times I \times A$$

$$Q_{100} = 0.35 \times 5.35 \text{ in/hr} \times 4.15 \text{ Ac} = \underline{\underline{7.77 \text{ cfs}}}$$

****Discharging from the site to the northwest in a culvert under Guajome Lake Rd**

Basin EX-2

Total Area = 188,893 sf → 4.34 Acres

Initial Slope ~10%, Land Use = Natural

T_i = 6.9 mins

*Table 3-2 per SDCHM

T_t = {[11.9*(307 ft / 5,280 ft/mile)³]/38.6 ft}^{0.385} = .024 hours
 = .024 hours * 60 min / hr 1.43 min

T_c = 6.9 + 1.43 = 8.33 min

T_c = **8.33 min**

P₆ = 2.9

I = 7.44 x P₆ x D^{-0.645}

I = 7.44 x 2.9 x 8.33^{-0.645} ≈ 5.5 in/hr

Q₁₀₀ = C*I*A

Q₁₀₀ = 0.35 x 5.5 in/hr x 4.34 Ac = **8.64 cfs**

****Discharging from the site to the southwest in a culvert under Guajome Lake Rd**

Basin EX-3

Total Area = 83,714 sf → 1.92 Acres

T_c = **5.0 min**

P₆ = 2.9

I = 7.44 x P₆ x D^{-0.645}

I = 7.44 x 2.9 x 5.0^{-0.645} ≈ 7.64 in/hr

I₁₀₀ ≈ 7.64 in/hr

Q₁₀₀ = C*I*A

Q₁₀₀ = 0.35 x 7.64 in/hr x 1.92 Ac = **5.13 cfs**

****Discharging from the site to the northeast in the existing stream**

Pre-Development – Total Site Runoff

Pre-Development (Basin EX-1)

Q₁₀₀ = 7.77 cfs

Pre-Development (Basin EX-2)

Q₁₀₀ = 8.35 cfs

Pre-Development (Basin EX-3)

Q₁₀₀ = 5.13 cfs

3.2 Post-Developed Hydrologic Model Output (100-Year Event)

Post-Development:

$$Q = CIA$$

$$P_{100} = 2.9$$

*Rational Method Equation
*100-Year, 6-Hour Rainfall Precipitation

Entire Disturbed Area (Onsite Drainage Basin)

Total Area = 453,625 sf → 10.41 Acres
Impervious Area = 275,690 sf → 6.33 Ac
Pervious Area = 177,665 sf → 4.08 Ac

Basin PR-1.1 (Discharging to BMP 1)

Total Area = 204,669 sf → 4.70 Acres
Impervious Area = 124,716 sf → 2.86 Ac
Pervious Area = 79,953 sf → 1.84 Ac

Cn, Weighted Runoff Coefficient,

- 0.35, Cn value for natural ground, Type D Soils

*Per San Diego County Hydrology Manual (SDCHM) Section 3.1.2

- 0.90, Cn value for developed/impervious surface

*Per SDCHM Section 3.1.2

$$Cn = \frac{0.35 \times 79,953 + .9 \times 124,716 \text{ sf}}{204,669 \text{ sf}} = 0.69$$

$$Cn = 0.69$$

*Weighted Runoff Coefficient for Onsite

$$Q = Cn \times I_{100} \times A$$

*Q based on flow to proposed BMP

Leaving the property across Guajome Lake Road to the northwest

$T_c = \mathbf{7.23 \text{ min}}$ (See attached AES calculations)

$Q_{100} = \mathbf{19.54 \text{ cfs}}$ (See attached AES calculations)

Basin PR-1.2 (Discharging to the Northwest of the site to San Luis Rey River)

Total Area = 25,401 sf → 0.58 Acres

Impervious Area = 19,578 sf → 0.45 Ac

Pervious Area = 5,823 sf → 0.13 Ac

Cn, Weighted Runoff Coefficient,

- 0.35, Cn value for natural ground, Type D Soils

*Per San Diego County Hydrology Manual (SDCHM) Section 3.1.2

- 0.90, Cn value for developed/impervious surface

*Per SDCHM Section 3.1.2

$$Cn = \frac{0.35 \times 5,823 + .9 \times 19,578 \text{ sf}}{25,401 \text{ sf}} = 0.77$$

Cn = 0.77

*Weighted Runoff Coefficient for Offsite

$$Q = Cn \times I_{100} \times A$$

*Q based on flow to proposed BMP

Leaving the property across Guajome Lake Road to the northwest

T_c = 7.38 min (See attached AES calculations)

Q₁₀₀ = 2.65 cfs (See attached AES calculations)

Basin PR-1 (Discharging to the Northwest of the site to San Luis Rey River)

Total Area = 230,070 sf → 5.28 Acres

Impervious Area = 144,294 sf → 3.31 Ac

Pervious Area = 85,776 sf → 1.97 Ac

Leaving the property across Guajome Lake Road to the northwest

T_c = 7.40 min (See attached AES calculations)

Q₁₀₀ = 21.90 cfs (See attached AES calculations)

Basin PR-2.1 (Discharging to BMP #2)

Total Area = 124,016 sf → 2.85 Acres
 Impervious Area = 86,009 sf → 1.97 Ac
 Pervious Area = 38,007 sf → 0.88 Ac

Cn, Weighted Runoff Coefficient,

- 0.35, Cn value for natural ground, Type D Soils

*Per San Diego County Hydrology Manual (SDCHM) Section 3.1.2

- 0.90, Cn value for developed/impervious surface

*Per SDCHM Section 3.1.2

$$Cn = \frac{0.35 \times 38,007 + .9 \times 86,009 \text{ sf}}{124,016 \text{ sf}} = 0.73$$

$$Cn = 0.73$$

$$Q = Cn \times I_{100} \times A$$

*Weighted Runoff Coefficient for Site

*Q based on flow to proposed BMP

Entering BMP #2

T_c = 7.53 min (See attached AES calculations)

Q₁₀₀ = 12.29 cfs (See attached AES calculations)

Basin PR-2.2 (Discharging to BMP #3)

Total Area = 46,503 sf → 1.07 Acres
 Impervious Area = 22,690 sf → 0.52 Ac
 Pervious Area = 23,813 sf → 0.55 Ac

Cn, Weighted Runoff Coefficient,

- 0.35, Cn value for natural ground, Type D Soils

*Per San Diego County Hydrology Manual (SDCHM) Section 3.1.2

- 0.90, Cn value for developed/impervious surface

*Per SDCHM Section 3.1.2

$$Cn = \frac{0.35 \times 23,813 + .9 \times 22,690 \text{ sf}}{46,503 \text{ sf}} = 0.62$$

$$Cn = 0.62$$

$$Q = Cn \times I_{100} \times A$$

*Weighted Runoff Coefficient for Site

*Q based on flow to proposed BMP

Entering BMP #2

T_c = 9.24 min (See attached AES calculations)

Q₁₀₀ = 3.75 cfs (See attached AES calculations)

Basin PR-2.3 (Discharging to the Southwest corner of the site)

Total Area = 36,617 sf → 0.84 Acres
 Impervious Area = 22,697 sf → 0.53 Ac
 Pervious Area = 13,650 sf → 0.31 Ac

Cn, Weighted Runoff Coefficient,
 - 0.35, Cn value for natural ground, Type D Soils
 *Per San Diego County Hydrology Manual (SDCHM) Section 3.1.2
 - 0.90, Cn value for developed/impervious surface
 *Per SDCHM Section 3.1.2

$$C_n = \frac{0.35 \times 13,650 + 0.9 \times 22,697 \text{ sf}}{36,617 \text{ sf}} = 0.70$$

$$C_n = 0.70$$

$$Q = C_n \times I_{100} \times A$$

*Weighted Runoff Coefficient for Site
 *Q based on flow to proposed BMP

$$T_c = \underline{7.66 \text{ min}} \text{ (See attached AES calculations)}$$

$$Q_{100} = \underline{3.41 \text{ cfs}} \text{ (See attached AES calculations)}$$

Basin PR-2 (Discharging to the Southwest corner of the site)

Total Area = 219,062 sf → 5.03 Acres
 Impervious Area = 135,181 sf → 3.10 Ac
 Pervious Area = 83,881 sf → 1.93 Ac

Discharging from the site to the southwest corner entering the existing inlet

$$T_c = \underline{7.66 \text{ min}} \text{ (See attached AES calculations)}$$

$$Q_{100} = \underline{19.33 \text{ cfs}} \text{ (See attached AES calculations)}$$

Basin PR-3

Total Area = 16,419 sf → 0.38 Acres

$$T_c = \underline{5.0 \text{ min}}$$

$$P_6 = 2.9$$

$$I = 7.44 \times P_6 \times D^{-0.645}$$

$$I = 7.44 \times 2.9 \times 5.0^{-0.645} \approx \underline{7.64 \text{ in/hr}}$$

$$I_{100} \approx \underline{7.64 \text{ in/hr}}$$

$$Q_{100} = C \times I \times A$$

$$Q_{100} = 0.67 \times 7.64 \text{ in/hr} \times 0.38 \text{ Ac} = \underline{1.01 \text{ cfs}}$$

****Discharging from the site to the northeast in the existing stream**

Pre-Development vs. Post-Development (Undetained – Total Site Runoff)

<u>Pre-Development (Basin EX-1)</u> Q₁₀₀ = 7.77 cfs	<u>Post-Development (PR-1)</u> Q₁₀₀ = 21.90 cfs	<u>Delta</u> 14.13 cfs
<u>Pre-Development (Basin EX-2)</u> Q₁₀₀ = 8.35 cfs	<u>Post-Development (PR-2)</u> Q₁₀₀ = 19.33 cfs	<u>Delta</u> 10.98 cfs
<u>Pre-Development (Basin EX-3)</u> Q₁₀₀ = 5.13 cfs	<u>Post-Development (PR-3)</u> Q₁₀₀ = 1.01 cfs	<u>Delta</u> -4.12 cfs

3.3 Detention Analysis (100-Year Event)

The onsite detention facilities consist of at-grade biofiltration basin BMP's to provide mitigation of the 100-year, 6-hour storm event peak flow rate. HydroCAD-10 software has the ability to route the 100-year, 6-hour storm event inflow hydrograph (generated and modeled using RatHydro, which is a Rational Method Design Storm Hydrograph software that creates a hydrograph using the results of the Rational Method calculations) through each biofiltration basin. Based on the basin cross-section geometry, stage-storage and outlet structure data, HydroCAD-10 has the ability to perform a dynamic / routing analysis and calculate the detained peak flow rate as well as detained time to peak.

All site runoff will be conveyed from the rear of each proposed lot out to the front by either sheet flow methods or within private storm drain piping. The majority of lots will discharge to the street before being routed to curb inlets that tie into the storm drain backbone system. Lots that cannot feasibly drain to the surface of the road will tie directly into the storm drain backbone system. Once in the storm drain backbone system runoff will be routed to one of three biofiltration basin BMP's for treatment in compliance with water quality requirements of the MS4 Permit, as well as detention. The biofiltration basin BMP's consists of a storage layer, engineered soil layer, and surface ponding with an emergency overflow grate located on top of the outlet structure. A subdrain system is proposed within the basin storage layer to route water to the proposed outlet structure, where flows will be metered into the box to comply with hydromodification criteria. Additionally, the outlet structure located within each biofiltration basin will further serve to mitigate peak flows before discharging directly offsite and has been designed for conjunctive use. This drainage path with both outlets from the biofiltration basin BMPs have been modeled in the HydroCAD-10 analysis as seen on the Routing Diagram included in Appendix B of this report.

PROPOSED DRAINAGE FLOWS (MIT)				
DRAINAGE AREA	DRAINAGE AREA (ACRES)	Q ₁₀₀ (CFS)	I ₁₀₀ (IN/HR)	DISCHARGE LOCATION
PR-1.1	4.70 Ac	5.85	3.96	BMP #1
PR-1.2	0.58 Ac	2.65	5.72	POC-1
PR-1 (TOT)	5.28 Ac	7.66	-	POC-1
PR-2.1	2.85 Ac	5.21	4.26	BMP #2
PR-2.2	1.07 Ac	0.83	3.44	BMP #3
PR-2.3	0.84 Ac	3.41	5.80	POC-2
PR-2 (Tot)	4.76 Ac	8.29	-	POC-2

Table 3. Proposed Condition Peak Drainage Flow Rates (Mitigated)

Table 3 above lists the peak flow rates for the project site in the proposed, mitigated condition after being routed through the onsite biofiltration basins and discharging from the property. Based on the results of the HydroCAD-10 analysis, the proposed biofiltration basins provide mitigation for the 100-year, 6-hour storm event peak flow rate. The resulting total peak discharge leaving the site for Basin PR-1 is 7.66 cfs, which is below the pre-development Q₁₀₀ of 7.77 cfs, and for Basin PR-2 is 8.29 cfs, which is below the pre-development Q₁₀₀ of 8.35 cfs at the same points of discharge just west of Guajome Lake Road.

3.3.1 Proposed Detained Condition Output Summary (100-Year Event)

Summary of Pre-Development Flows

Peak Runoff Generated (At Northwest Corner)

Total Area = 180,901 sf (EX-1) → 4.15 Acres

Q₁₀₀ = 7.77 cfs

Peak Runoff Generated (At Southwest Corner)

Total Area = 188,983 sf (EX-2) → 4.34 Acres

Q₁₀₀ = 8.35 cfs

Peak Runoff Generated (At Northeast Corner)

Total Area = 83,714 sf (EX-3) → 1.92 Acres

Q₁₀₀ = 5.13 cfs

Summary of Post-Development Flows (Mitigated)

Peak Runoff Generated (At Northwest Corner)

Total Area = 230,070 sf (PR-1) → 5.28 Acres

Q₁₀₀ = 7.66 cfs < 7.77 cfs in the existing condition

Peak Runoff Generated (At Southwest Corner)

Total Area = 207,136 sf (PR-2) → 4.76 Acres

Q₁₀₀ = 8.29 cfs < 8.35 cfs in the existing condition

Peak Runoff Generated (At Northeast Corner)

Total Area = 16,419 sf (PR-3) → 0.38 Acres

Q₁₀₀ = 1.01 cfs < 5.13 cfs in the existing condition

3.4 Hydromodification Analysis

Refer to the project Storm Water Quality Management Plan (SWQMP) prepared by Pasco, Laret, Suiter & Associates under separate cover for discussion of hydromodification management strategy and compliance to satisfy the requirements of the MS4 Permit.

3.5 Storm Water Pollutant Control

To meet the requirements of the MS4 Permit, the storm water treatment facilities are designed to treat onsite storm water pollutants contained in the volume of runoff from a 24-hour, 85th percentile storm event by infiltrating runoff through an engineered soil layer. Refer to the project Storm Water Quality Management Plan (SWQMP) prepared by Pasco, Laret, Suiter & Associates under separate cover for discussion of pollutant control.

APPENDIX A

Hydrology Support Material

County of San Diego Hydrology Manual



Rainfall Isophuvials

100 Year Rainfall Event - 6 Hours

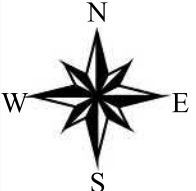
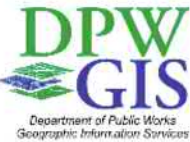
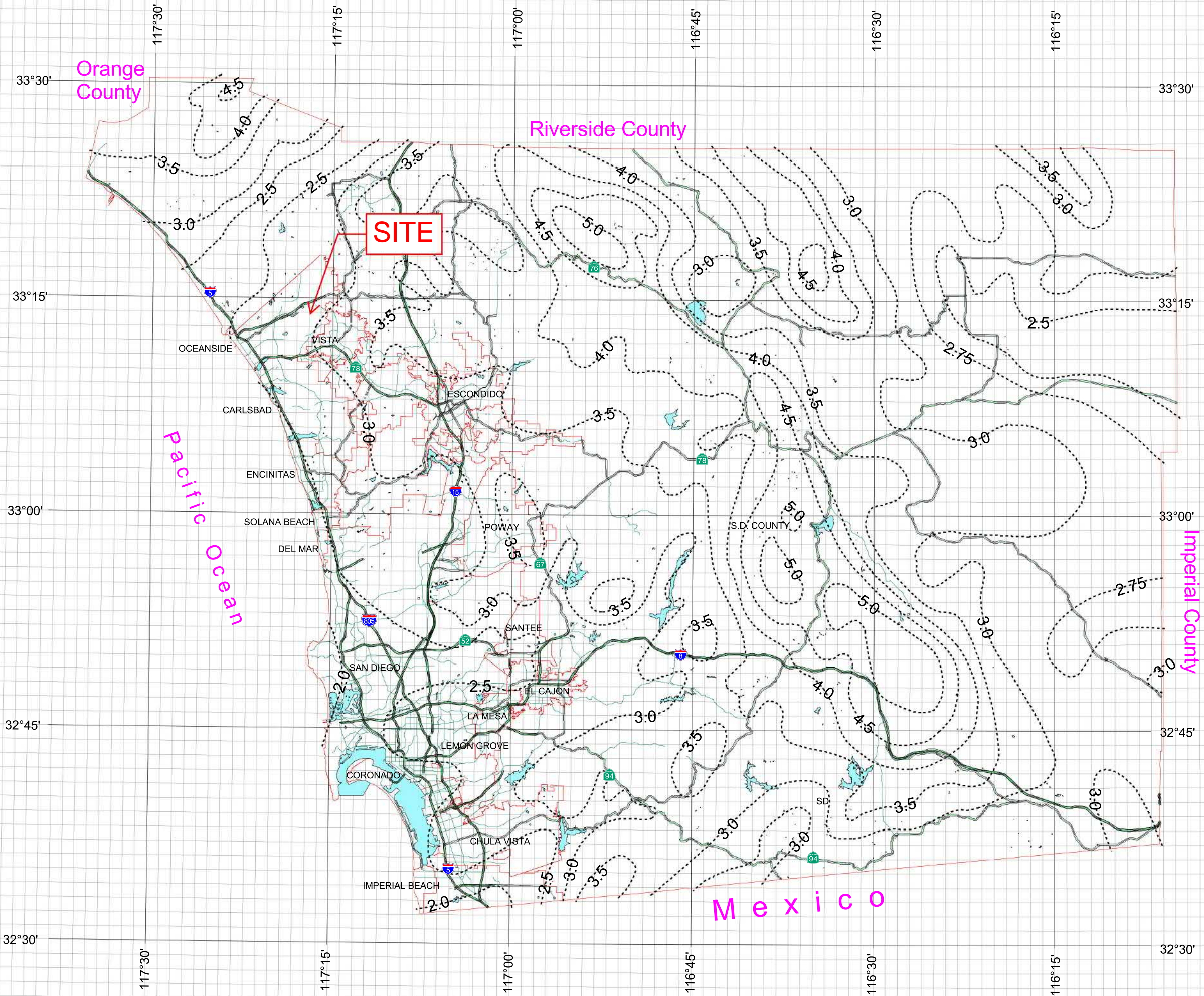
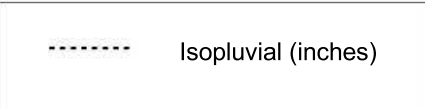

THIS MAP IS PROVIDED WITHOUT WARRANTY OF ANY KIND, EITHER EXPRESS OR IMPLIED, INCLUDING, BUT NOT LIMITED TO, THE IMPLIED WARRANTIES OF MERCHANTABILITY AND FITNESS FOR A PARTICULAR PURPOSE. Copyright SanGIS. All Rights Reserved.

This products may contain information from the SANDAG Regional Information System which cannot be reproduced without the written permission of SANDAG.

This product may contain information which has been reproduced with permission granted by Thomas Brothers Maps.

County of San Diego Hydrology Manual



Rainfall Isopluvials

100 Year Rainfall Event - 24 Hours

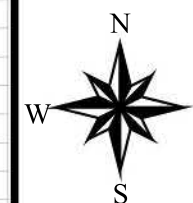
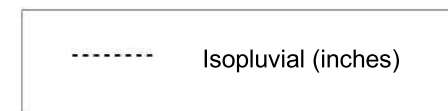

THIS MAP IS PROVIDED WITHOUT WARRANTY OF ANY KIND, EITHER EXPRESS OR IMPLIED, INCLUDING, BUT NOT LIMITED TO, THE IMPLIED WARRANTIES OF MERCHANTABILITY AND FITNESS FOR A PARTICULAR PURPOSE. Copyright SanGIS. All Rights Reserved.

This product may contain information from the SANDAG Regional Information System which cannot be reproduced without the written permission of SANDAG.

This product may contain information which has been reproduced with permission granted by Thomas Brothers Maps.

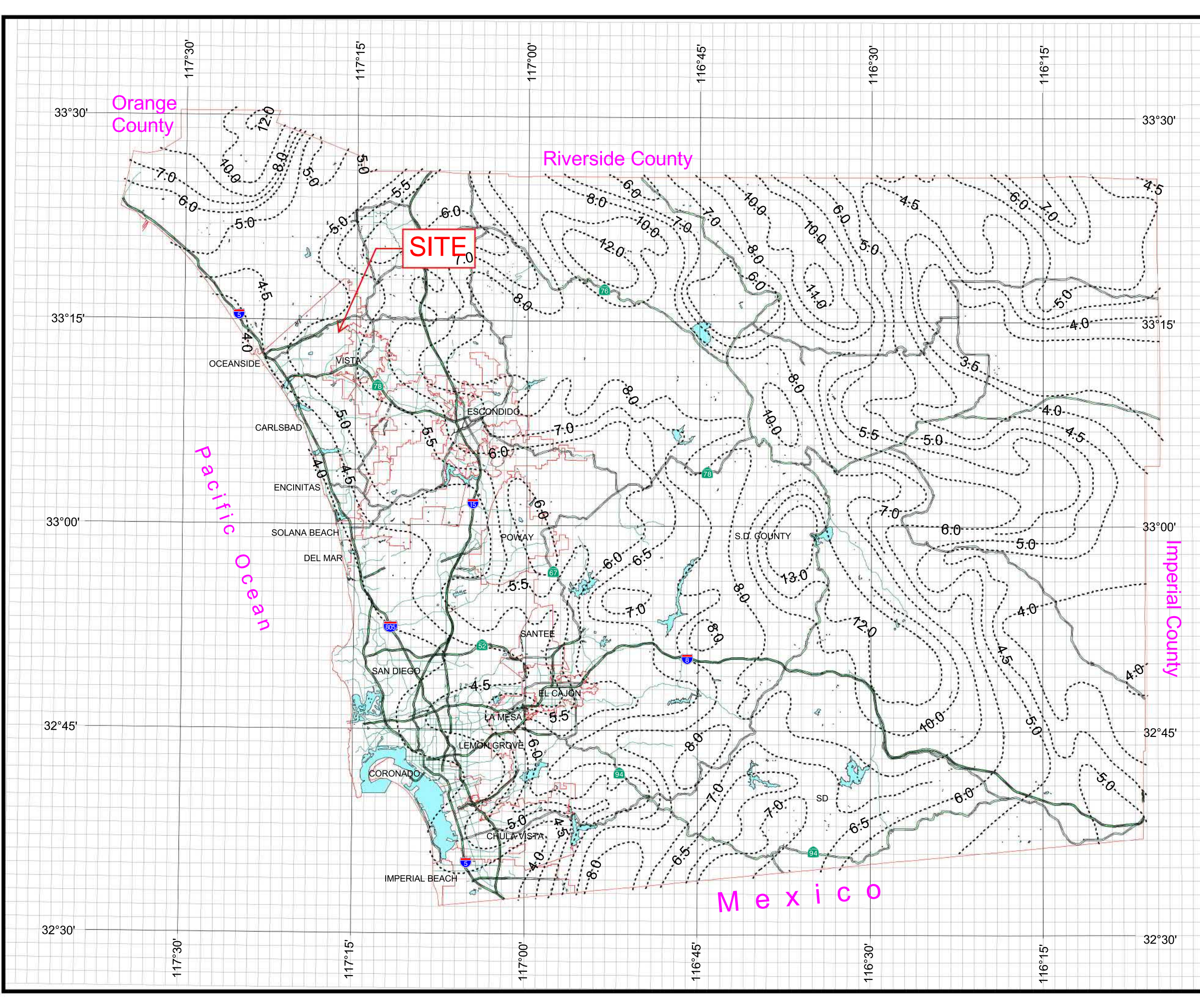

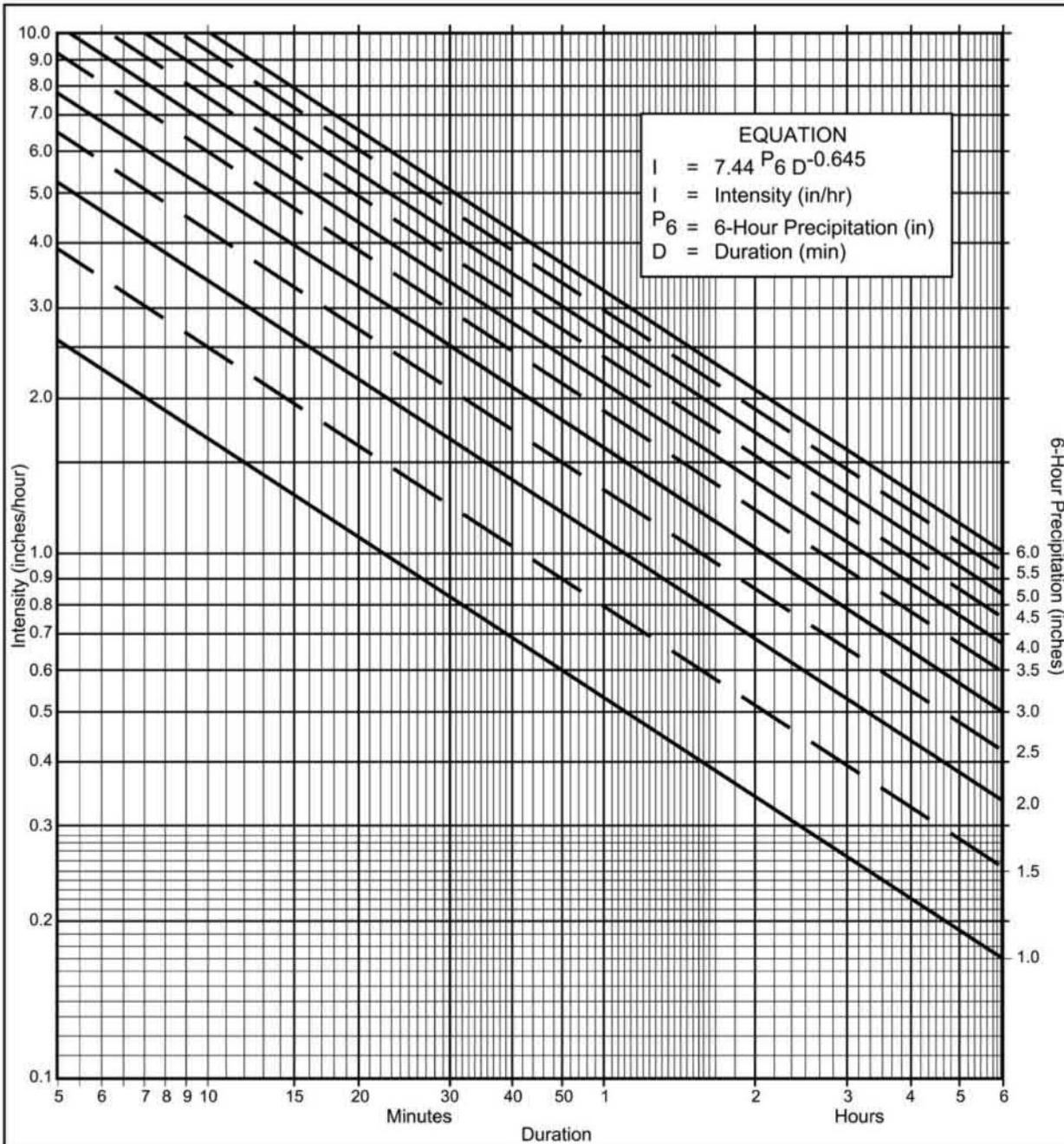

Directions for Application:

- (1) From precipitation maps determine 6 hr and 24 hr amounts for the selected frequency. These maps are included in the County Hydrology Manual (10, 50, and 100 yr maps included in the Design and Procedure Manual).
- (2) Adjust 6 hr precipitation (if necessary) so that it is within the range of 45% to 65% of the 24 hr precipitation (not applicable to Desert).
- (3) Plot 6 hr precipitation on the right side of the chart.
- (4) Draw a line through the point parallel to the plotted lines.
- (5) This line is the intensity-duration curve for the location being analyzed.

Application Form:

- (a) Selected frequency 100 year
- (b) $P_6 = \underline{2.9}$ in., $P_{24} = \underline{5.2}$, $\frac{P_6}{P_{24}} = \underline{56}$ %⁽²⁾
- (c) Adjusted $P_6^{(2)} = \underline{2.9}$ in.
- (d) $t_x = \underline{\text{varies}}$ min.
- (e) $I = \underline{\text{varies}}$ in./hr.

Note: This chart replaces the Intensity-Duration-Frequency curves used since 1965.

P6	1	1.5	2	2.5	3	3.5	4	4.5	5	5.5	6
5	2.63	3.95	5.27	6.59	7.90	9.22	10.54	11.86	13.17	14.49	15.81
7	2.12	3.18	4.24	5.30	6.36	7.42	8.48	9.54	10.60	11.66	12.72
10	1.68	2.53	3.37	4.21	5.05	5.90	6.74	7.58	8.42	9.27	10.11
15	1.30	1.95	2.59	3.24	3.89	4.54	5.19	5.84	6.49	7.13	7.78
20	1.08	1.62	2.15	2.69	3.23	3.77	4.31	4.85	5.39	5.93	6.46
25	0.93	1.40	1.87	2.33	2.80	3.27	3.73	4.20	4.67	5.13	5.60
30	0.83	1.24	1.66	2.07	2.49	2.90	3.32	3.73	4.15	4.56	4.98
40	0.69	1.03	1.38	1.72	2.07	2.41	2.76	3.10	3.45	3.79	4.13
50	0.60	0.90	1.19	1.49	1.79	2.09	2.39	2.69	2.98	3.28	3.58
60	0.53	0.80	1.06	1.33	1.59	1.86	2.12	2.39	2.65	2.92	3.18
90	0.41	0.61	0.82	1.02	1.23	1.43	1.63	1.84	2.04	2.25	2.45
120	0.34	0.51	0.68	0.85	1.02	1.19	1.36	1.53	1.70	1.87	2.04
150	0.29	0.44	0.59	0.73	0.88	1.03	1.18	1.32	1.47	1.62	1.76
180	0.26	0.39	0.52	0.65	0.78	0.91	1.04	1.18	1.31	1.44	1.57
240	0.22	0.33	0.43	0.54	0.65	0.76	0.87	0.98	1.08	1.19	1.30
300	0.19	0.28	0.38	0.47	0.56	0.66	0.75	0.85	0.94	1.03	1.13
360	0.17	0.25	0.33	0.42	0.50	0.58	0.67	0.75	0.84	0.92	1.00

Intensity-Duration Design Chart - Template

FIGURE

3-1

**Table 3-1
RUNOFF COEFFICIENTS FOR URBAN AREAS**

Land Use		Runoff Coefficient "C"				
		Soil Type				
NRCS Elements	County Elements	% IMPER.	A	B	C	D
Undisturbed Natural Terrain (Natural)	Permanent Open Space	0*	0.20	0.25	0.30	0.35
Low Density Residential (LDR)	Residential, 1.0 DU/A or less	10	0.27	0.32	0.36	0.41
Low Density Residential (LDR)	Residential, 2.0 DU/A or less	20	0.34	0.38	0.42	0.46
Low Density Residential (LDR)	Residential, 2.9 DU/A or less	25	0.38	0.41	0.45	0.49
Medium Density Residential (MDR)	Residential, 4.3 DU/A or less	30	0.41	0.45	0.48	0.52
Medium Density Residential (MDR)	Residential, 7.3 DU/A or less	40	0.48	0.51	0.54	0.57
Medium Density Residential (MDR)	Residential, 10.9 DU/A or less	45	0.52	0.54	0.57	0.60
Medium Density Residential (MDR)	Residential, 14.5 DU/A or less	50	0.55	0.58	0.60	0.63
High Density Residential (HDR)	Residential, 24.0 DU/A or less	65	0.66	0.67	0.69	0.71
High Density Residential (HDR)	Residential, 43.0 DU/A or less	80	0.76	0.77	0.78	0.79
Commercial/Industrial (N. Com)	Neighborhood Commercial	80	0.76	0.77	0.78	0.79
Commercial/Industrial (G. Com)	General Commercial	85	0.80	0.80	0.81	0.82
Commercial/Industrial (O.P. Com)	Office Professional/Commercial	90	0.83	0.84	0.84	0.85
Commercial/Industrial (Limited I.)	Limited Industrial	90	0.83	0.84	0.84	0.85
Commercial/Industrial (General I.)	General Industrial	95	0.87	0.87	0.87	0.87

*The values associated with 0% impervious may be used for direct calculation of the runoff coefficient as described in Section 3.1.2 (representing the pervious runoff coefficient, Cp, for the soil type), or for areas that will remain undisturbed in perpetuity. Justification must be given that the area will remain natural forever (e.g., the area is located in Cleveland National Forest).

DU/A = dwelling units per acre

NRCS = National Resources Conservation Service

Note that the Initial Time of Concentration should be reflective of the general land-use at the upstream end of a drainage basin. A single lot with an area of two or less acres does not have a significant effect where the drainage basin area is 20 to 600 acres.

Table 3-2 provides limits of the length (Maximum Length (L_M)) of sheet flow to be used in hydrology studies. Initial T_i values based on average C values for the Land Use Element are also included. These values can be used in planning and design applications as described below. Exceptions may be approved by the “Regulating Agency” when submitted with a detailed study.

Table 3-2

**MAXIMUM OVERLAND FLOW LENGTH (L_M)
 & INITIAL TIME OF CONCENTRATION (T_i)**

Element*	DU/ Acre	.5%		1%		2%		3%		5%		10%	
		L_M	T_i	L_M	T_i	L_M	T_i	L_M	T_i	L_M	T_i	L_M	T_i
Natural		50	13.2	70	12.5	85	10.9	100	10.3	100	8.7	100	6.9
LDR	1	50	12.2	70	11.5	85	10.0	100	9.5	100	8.0	100	6.4
LDR	2	50	11.3	70	10.5	85	9.2	100	8.8	100	7.4	100	5.8
LDR	2.9	50	10.7	70	10.0	85	8.8	95	8.1	100	7.0	100	5.6
MDR	4.3	50	10.2	70	9.6	80	8.1	95	7.8	100	6.7	100	5.3
MDR	7.3	50	9.2	65	8.4	80	7.4	95	7.0	100	6.0	100	4.8
MDR	10.9	50	8.7	65	7.9	80	6.9	90	6.4	100	5.7	100	4.5
MDR	14.5	50	8.2	65	7.4	80	6.5	90	6.0	100	5.4	100	4.3
HDR	24	50	6.7	65	6.1	75	5.1	90	4.9	95	4.3	100	3.5
HDR	43	50	5.3	65	4.7	75	4.0	85	3.8	95	3.4	100	2.7
N. Com		50	5.3	60	4.5	75	4.0	85	3.8	95	3.4	100	2.7
G. Com		50	4.7	60	4.1	75	3.6	85	3.4	90	2.9	100	2.4
O.P./Com		50	4.2	60	3.7	70	3.1	80	2.9	90	2.6	100	2.2
Limited I.		50	4.2	60	3.7	70	3.1	80	2.9	90	2.6	100	2.2
General I.		50	3.7	60	3.2	70	2.7	80	2.6	90	2.3	100	1.9

*See Table 3-1 for more detailed description

Hydrologic Soil Group—San Diego County Area, California



Map Scale: 1:2,970 if printed on A landscape (11" x 8.5") sheet.

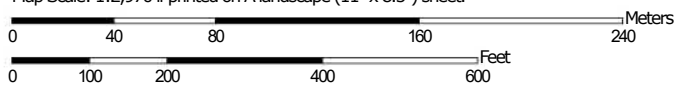

Map projection: Web Mercator Corner coordinates: WGS84 Edge tics: UTM Zone 11N WGS84











MAP LEGEND

Area of Interest (AOI)









 Area of Interest (AOI)

Soils



Soil Rating Polygons





 A
 A/D
 B
 B/D
 C
 C/D
 D
 Not rated or not available

Soil Rating Lines

 A
 A/D
 B
 B/D
 C
 C/D
 D
 Not rated or not available

Soil Rating Points

 A
 A/D
 B
 B/D

 C
 C/D
 D
 Not rated or not available

Water Features

 Streams and Canals

Transportation

 Rails
 Interstate Highways
 US Routes
 Major Roads
 Local Roads

Background

 Aerial Photography

MAP INFORMATION

The soil surveys that comprise your AOI were mapped at 1:24,000.

Warning: Soil Map may not be valid at this scale.

Enlargement of maps beyond the scale of mapping can cause misunderstanding of the detail of mapping and accuracy of soil line placement. The maps do not show the small areas of contrasting soils that could have been shown at a more detailed scale.

Please rely on the bar scale on each map sheet for map measurements.

Source of Map: Natural Resources Conservation Service
 Web Soil Survey URL:
 Coordinate System: Web Mercator (EPSG:3857)

Maps from the Web Soil Survey are based on the Web Mercator projection, which preserves direction and shape but distorts distance and area. A projection that preserves area, such as the Albers equal-area conic projection, should be used if more accurate calculations of distance or area are required.

This product is generated from the USDA-NRCS certified data as of the version date(s) listed below.

Soil Survey Area: San Diego County Area, California
 Survey Area Data: Version 16, Sep 13, 2021

Soil map units are labeled (as space allows) for map scales 1:50,000 or larger.

Date(s) aerial images were photographed: Jan 24, 2020—Feb 12, 2020

The orthophoto or other base map on which the soil lines were compiled and digitized probably differs from the background imagery displayed on these maps. As a result, some minor shifting of map unit boundaries may be evident.

Hydrologic Soil Group

Map unit symbol	Map unit name	Rating	Acres in AOI	Percent of AOI
BsD	Bosanko clay, 9 to 15 percent slopes	D	0.6	3.3%
LeD2	Las Flores loamy fine sand, 9 to 15 percent slopes, eroded	D	9.7	56.4%
LeE2	Las Flores loamy fine sand, 15 to 30 percent slopes, eroded	D	2.9	17.0%
VaB	Visalia sandy loam, 2 to 5 percent slopes	A	4.0	23.2%
Totals for Area of Interest			17.1	100.0%

Description

Hydrologic soil groups are based on estimates of runoff potential. Soils are assigned to one of four groups according to the rate of water infiltration when the soils are not protected by vegetation, are thoroughly wet, and receive precipitation from long-duration storms.

The soils in the United States are assigned to four groups (A, B, C, and D) and three dual classes (A/D, B/D, and C/D). The groups are defined as follows:

Group A. Soils having a high infiltration rate (low runoff potential) when thoroughly wet. These consist mainly of deep, well drained to excessively drained sands or gravelly sands. These soils have a high rate of water transmission.

Group B. Soils having a moderate infiltration rate when thoroughly wet. These consist chiefly of moderately deep or deep, moderately well drained or well drained soils that have moderately fine texture to moderately coarse texture. These soils have a moderate rate of water transmission.

Group C. Soils having a slow infiltration rate when thoroughly wet. These consist chiefly of soils having a layer that impedes the downward movement of water or soils of moderately fine texture or fine texture. These soils have a slow rate of water transmission.

Group D. Soils having a very slow infiltration rate (high runoff potential) when thoroughly wet. These consist chiefly of clays that have a high shrink-swell potential, soils that have a high water table, soils that have a claypan or clay layer at or near the surface, and soils that are shallow over nearly impervious material. These soils have a very slow rate of water transmission.

If a soil is assigned to a dual hydrologic group (A/D, B/D, or C/D), the first letter is for drained areas and the second is for undrained areas. Only the soils that in their natural condition are in group D are assigned to dual classes.

Rating Options

Aggregation Method: Dominant Condition

Component Percent Cutoff: None Specified

Tie-break Rule: Higher

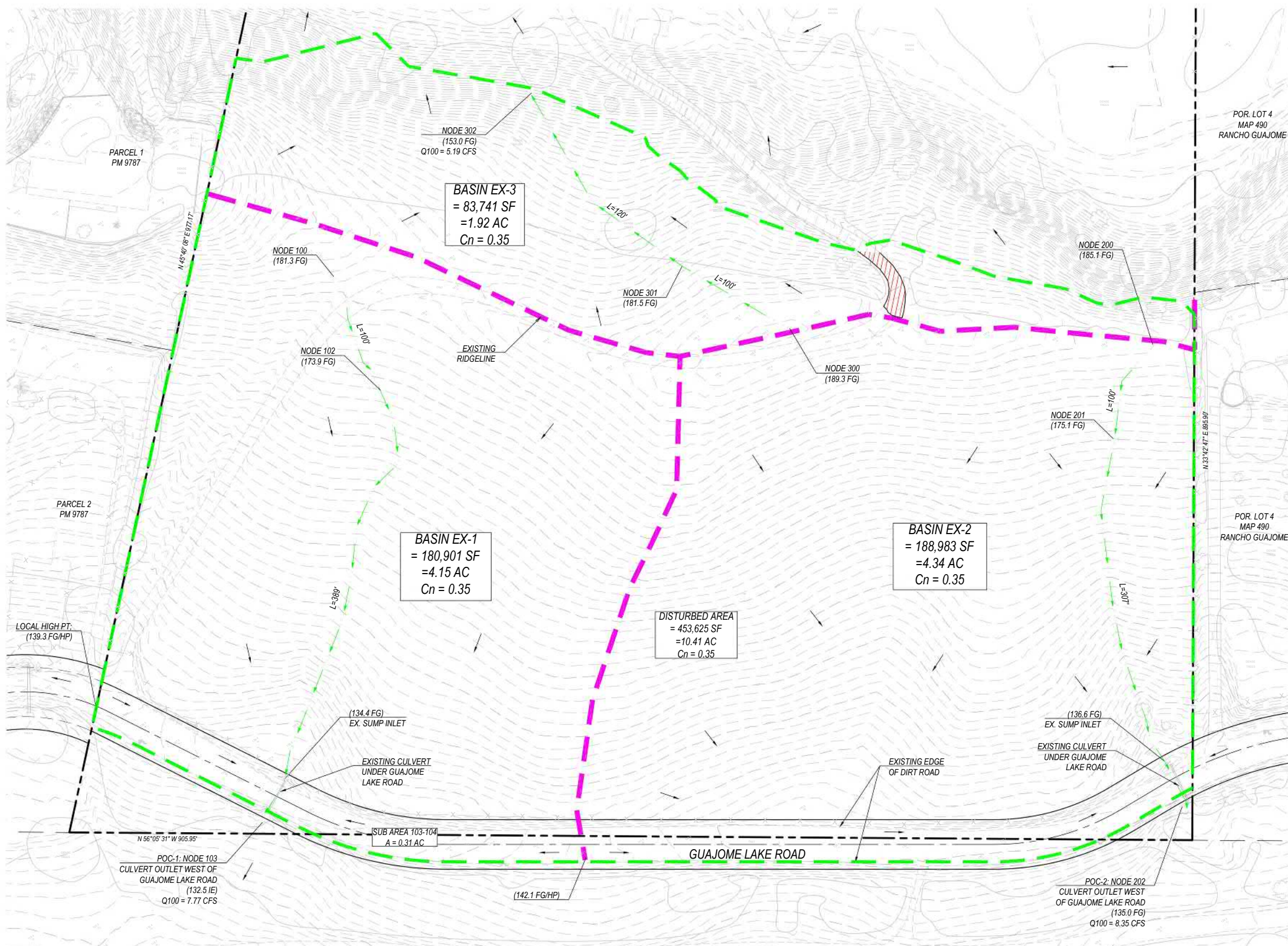

LEGEND

- PROPERTY LINE
- RIGHT-OF-WAY
- CENTERLINE OF ROAD
- ADJACENT LOT LINE
- EXISTING FLOW PATH
- FLOW DIRECTION
- EXISTING MAJOR DRAINAGE BASIN BOUNDARY
- EXISTING IMPERVIOUS AREA

PROJECT SITE - AREA CALCULATIONS

TOTAL DISTURBED / ANALYZED AREA	453,625 SF (10.41 AC)
EXISTING PERVIOUS AREA	700 SF (0.016 AC)
EXISTING IMPERVIOUS AREA	452,925 SF (10.39 AC)
IMPERVIOUS %	-0.0%
Cn	0.35

BASIN EX-1 - AREA CALCULATIONS

TOTAL DRAINAGE BASIN AREA	180,901 SF (4.15 AC)
Cn	0.35
Q100	7.77 CFS
TC	8.7 MINS

BASIN EX-2 - AREA CALCULATIONS

TOTAL DRAINAGE BASIN AREA	188,983 SF (4.34 AC)
Cn	0.35
Q100	8.35 CFS
TC	8.3 MINS

BASIN EX-3 - AREA CALCULATIONS

TOTAL DRAINAGE BASIN AREA	83,741 SF (1.92 AC)
Cn	0.35
Q100	5.13 CFS
TC	5.0 MINS

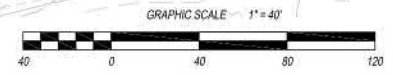

EXISTING HYDROLOGY EXHIBIT **PASCO LARET SUITER**
& ASSOCIATES
San Diego | Solana Beach | Orange County
Phone 858.259.8212 | www.plsaengineering.com

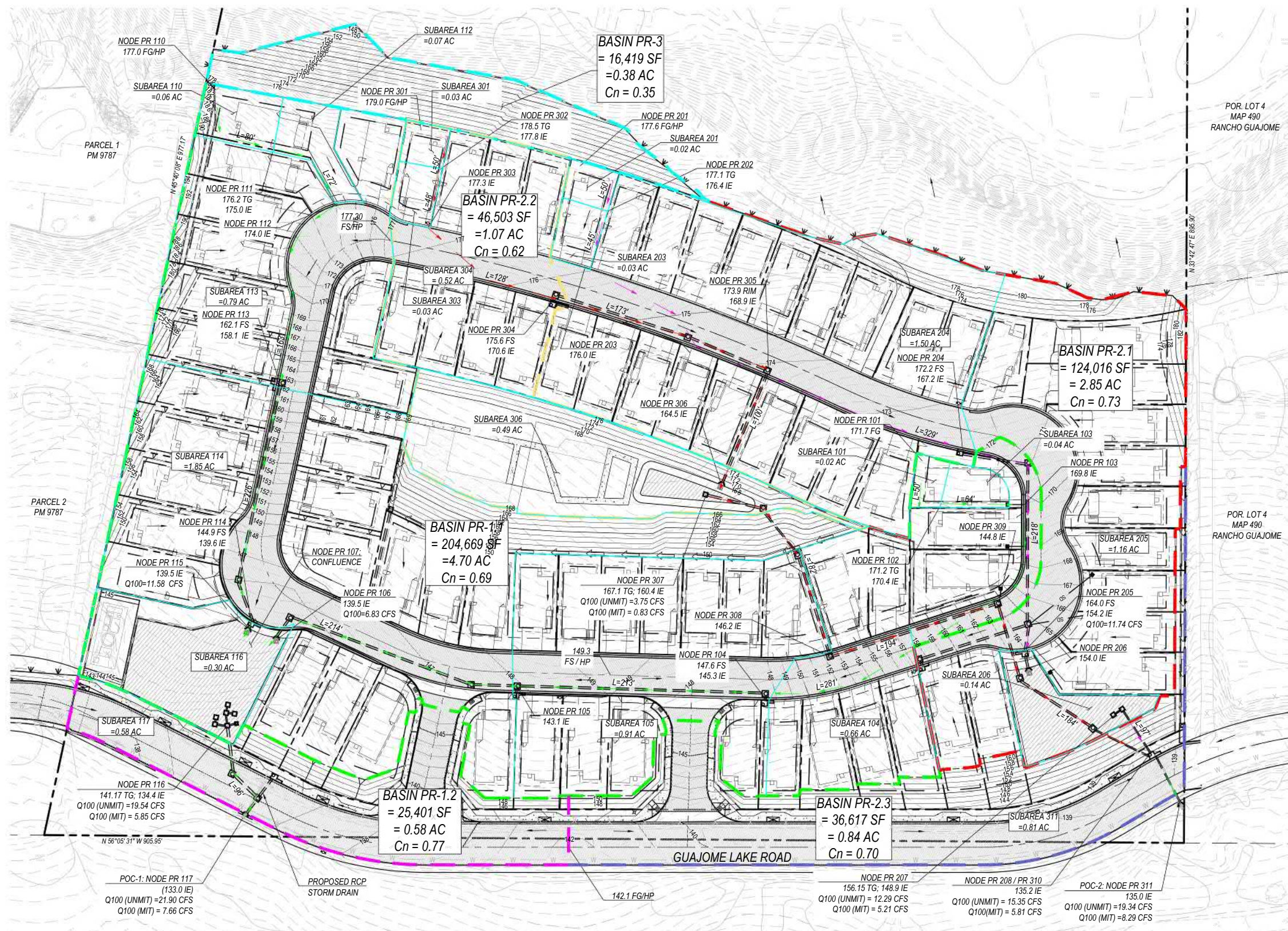

LEGEND

- PROPERTY LINE
- RIGHT-OF-WAY
- CENTERLINE OF ROAD
- FLOW PATH (PR-1.1)
- FLOW PATH (PR-2.1)
- FLOW PATH (PR-2.2)
- FLOW DIRECTION
- PROPOSED MAJOR BASIN 1.1 BOUNDARY
- PROPOSED MAJOR BASIN 1.2 BOUNDARY
- PROPOSED MAJOR BASIN 2.1 BOUNDARY
- PROPOSED MAJOR BASIN 2.2 BOUNDARY
- PROPOSED MAJOR BASIN 2.3 BOUNDARY
- PROPOSED BASIN SUBAREA

PROJECT SITE - AREA CALCULATIONS

TOTAL AREA	453,625 SF (10.41 AC)
PROPOSED IMPERVIOUS AREA	275,690 SF (6.33 AC)
PROPOSED PERVIOUS AREA	177,935 SF (4.08 AC)
IMPERVIOUS %	60.8%

BASIN PR-1.1 - AREA CALCULATIONS

TOTAL BASIN AREA	204,669 SF (4.70 AC)
PROPOSED IMPERVIOUS AREA	124,716 SF (2.86 AC)
PROPOSED PERVIOUS AREA	79,953 SF (1.84 AC)
Cn	0.69
Q100 (UNMIT)	19.54 CFS
Q100 (MIT)	5.85 CFS
TC(UNMIT)	7.40 MINS
TC(MIT)	13.13 MINS

BASIN PR-1.2 - AREA CALCULATIONS

TOTAL BASIN AREA	25,401 SF (0.58 AC)
PROPOSED IMPERVIOUS AREA	19,578 SF (0.45 AC)
PROPOSED PERVIOUS AREA	5,823 SF (0.13 AC)
Cn	0.77
Q100	2.65 CFS

BASIN PR-2.1 - AREA CALCULATIONS

TOTAL BASIN AREA	230,070 SF (5.28 AC)
Q100 (UNMIT)	21.90 CFS
Q100 (MIT)	7.66 CFS
TC(UNMIT)	7.40 mins
TC(MIT)	13.33 MINS

PLAN VIEW - PROPOSED HYDROLOGY NODE MAP
SCALE: 1" = 40' HORIZONTAL

BASIN PR-2.1 - AREA CALCULATIONS

TOTAL BASIN AREA	124,016 SF (2.85 AC)
PROPOSED IMPERVIOUS AREA	86,009 SF (1.97 AC)
PROPOSED PERVIOUS AREA	38,007 SF (0.88 AC)
Cn	0.73
Q100 (UNMIT)	12.29 CFS
Q100 (MIT)	5.21 CFS
TC(UNMIT)	7.45 MINS
TC(MIT)	12.25 MINS

BASIN PR-2.2 - AREA CALCULATIONS

TOTAL BASIN AREA	46,503 SF (1.07 AC)
PROPOSED IMPERVIOUS AREA	22,690 SF (0.52 AC)
PROPOSED PERVIOUS AREA	23,813 SF (0.55 AC)
Cn	0.62
Q100 (UNMIT)	3.75 CFS
Q100 (MIT)	0.83 CFS
TC(UNMIT)	9.24 MINS
TC(MIT)	16.24 MINS

BASIN PR-2.3 - AREA CALCULATIONS

TOTAL BASIN AREA	36,617 SF (0.84 AC)
PROPOSED IMPERVIOUS AREA	22,967 SF (0.53 AC)
PROPOSED PERVIOUS AREA	13,650 SF (0.31 AC)
Cn	0.70
Q100 (UNMIT)	3.41 CFS

BASIN PR-2 - AREA CALCULATIONS

TOTAL BASIN AREA	207,136 SF (4.76 AC)
Q100 (UNMIT)	19.34 CFS
Q100 (MIT)	8.29 CFS
TC(UNMIT)	7.66 MINS
TC(MIT)	12.52 MINS

BASIN PR-3 - AREA CALCULATIONS

TOTAL BASIN AREA	16,419 SF (0.38 AC)
Cn	0.35
Q100	1.01 CFS
TC	5.0 MINS

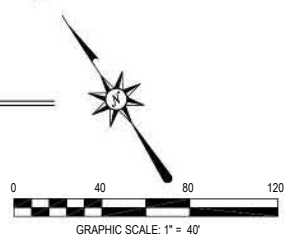

PROPOSED HYDROLOGY EXHIBIT
GUAJOME LAKE ROAD
CITY OF OCEANSIDE, CA

PREPARED BY:
PASCO LARET SUTER & ASSOCIATES
San Diego | Encinitas | Orange County
Phone 858.259.8212 | www.plsengineering.com

RATIONAL METHOD HYDROLOGY COMPUTER PROGRAM PACKAGE
Reference: SAN DIEGO COUNTY FLOOD CONTROL DISTRICT
2003,1985,1981 HYDROLOGY MANUAL

(c) Copyright 1982-2016 Advanced Engineering Software (aes)
Ver. 23.0 Release Date: 07/01/2016 License ID 1452

Analysis prepared by:

***** DESCRIPTION OF STUDY *****

- * PASCO LARET SUITER & ASSOC *
- * BASIN PR-1 (UNMIT) *
- * GUAJOME LAKE *

FILE NAME: PR13775.DAT
TIME/DATE OF STUDY: 14:53 08/15/2024

USER SPECIFIED HYDROLOGY AND HYDRAULIC MODEL INFORMATION:

2003 SAN DIEGO MANUAL CRITERIA

USER SPECIFIED STORM EVENT(YEAR) = 100.00
6-HOUR DURATION PRECIPITATION (INCHES) = 2.900
SPECIFIED MINIMUM PIPE SIZE(INCH) = 3.00
SPECIFIED PERCENT OF GRADIENTS(DECIMAL) TO USE FOR FRICTION SLOPE = 0.95
SAN DIEGO HYDROLOGY MANUAL "C"-VALUES USED FOR RATIONAL METHOD
NOTE: USE MODIFIED RATIONAL METHOD PROCEDURES FOR CONFLUENCE ANALYSIS

USER-DEFINED STREET-SECTIONS FOR COUPLED PIPEFLOW AND STREETFLOW MODEL

NO.	HALF- WIDTH (FT)	CROWN TO CROSSFALL (FT)	STREET-CROSSFALL: IN- / OUT-/ SIDE / SIDE/ WAY	CURB HEIGHT (FT)	GUTTER-GEOMETRIES: WIDTH (FT)	LIP (FT)	HIKE (FT)	MANNING FACTOR (n)
1	16.0	11.0	0.018/0.018/0.020	0.50	1.50	0.0312	0.125	0.0150

GLOBAL STREET FLOW-DEPTH CONSTRAINTS:

1. Relative Flow-Depth = 0.50 FEET
as (Maximum Allowable Street Flow Depth) - (Top-of-Curb)
2. (Depth)*(Velocity) Constraint = 6.0 (FT*FT/S)

*SIZE PIPE WITH A FLOW CAPACITY GREATER THAN
OR EQUAL TO THE UPSTREAM TRIBUTARY PIPE.*

FLOW PROCESS FROM NODE 101.00 TO NODE 102.00 IS CODE = 21

>>>>RATIONAL METHOD INITIAL SUBAREA ANALYSIS<<<<<

=====

*USER SPECIFIED(SUBAREA):

RESIDENTIAL (1. DU/AC OR LESS) RUNOFF COEFFICIENT = .6900
S.C.S. CURVE NUMBER (AMC II) = 0
INITIAL SUBAREA FLOW-LENGTH(FEET) = 50.00
UPSTREAM ELEVATION(FEET) = 171.70
DOWNSTREAM ELEVATION(FEET) = 171.20
ELEVATION DIFFERENCE(FEET) = 0.50
SUBAREA OVERLAND TIME OF FLOW(MIN.) = 5.218
100 YEAR RAINFALL INTENSITY(INCH/HOUR) = 7.433
SUBAREA RUNOFF(CFS) = 0.10
TOTAL AREA(ACRES) = 0.02 TOTAL RUNOFF(CFS) = 0.10

FLOW PROCESS FROM NODE 102.00 TO NODE 103.00 IS CODE = 31

>>>>COMPUTE PIPE-FLOW TRAVEL TIME THRU SUBAREA<<<<<

>>>>USING COMPUTER-ESTIMATED PIPESIZE (NON-PRESSURE FLOW)<<<<<

=====

ELEVATION DATA: UPSTREAM(FEET) = 171.20 DOWNSTREAM(FEET) = 169.80
FLOW LENGTH(FEET) = 64.00 MANNING'S N = 0.013
DEPTH OF FLOW IN 3.0 INCH PIPE IS 2.1 INCHES
PIPE-FLOW VELOCITY(FEET/SEC.) = 2.80
ESTIMATED PIPE DIAMETER(INCH) = 3.00 NUMBER OF PIPES = 1
PIPE-FLOW(CFS) = 0.10
PIPE TRAVEL TIME(MIN.) = 0.38 Tc(MIN.) = 5.60
LONGEST FLOWPATH FROM NODE 101.00 TO NODE 103.00 = 114.00 FEET.

FLOW PROCESS FROM NODE 103.00 TO NODE 103.00 IS CODE = 81

>>>>ADDITION OF SUBAREA TO MAINLINE PEAK FLOW<<<<<

=====

100 YEAR RAINFALL INTENSITY(INCH/HOUR) = 7.102
*USER SPECIFIED(SUBAREA):
RESIDENTIAL (1. DU/AC OR LESS) RUNOFF COEFFICIENT = .6900
S.C.S. CURVE NUMBER (AMC II) = 0
AREA-AVERAGE RUNOFF COEFFICIENT = 0.6900
SUBAREA AREA(ACRES) = 0.04 SUBAREA RUNOFF(CFS) = 0.20
TOTAL AREA(ACRES) = 0.1 TOTAL RUNOFF(CFS) = 0.29
TC(MIN.) = 5.60

FLOW PROCESS FROM NODE 103.00 TO NODE 104.00 IS CODE = 62

>>>>COMPUTE STREET FLOW TRAVEL TIME THRU SUBAREA<<<<<

>>>>(STREET TABLE SECTION # 1 USED)<<<<<

=====

UPSTREAM ELEVATION(FEET) = 169.80 DOWNSTREAM ELEVATION(FEET) = 147.60
STREET LENGTH(FEET) = 281.00 CURB HEIGHT(INCHES) = 6.0
STREET HALFWIDTH(FEET) = 16.00

DISTANCE FROM CROWN TO CROSSFALL GRADEBREAK(FEET) = 11.00
INSIDE STREET CROSSFALL(DECIMAL) = 0.018
OUTSIDE STREET CROSSFALL(DECIMAL) = 0.018

SPECIFIED NUMBER OF HALFSTREETS CARRYING RUNOFF = 1
STREET PARKWAY CROSSFALL(DECIMAL) = 0.020
Manning's FRICTION FACTOR for Streetflow Section(curbs-to-curbs) = 0.0150
Manning's FRICTION FACTOR for Back-of-Walk Flow Section = 0.0200

**TRAVEL TIME COMPUTED USING ESTIMATED FLOW(CFS) = 1.75
STREETFLOW MODEL RESULTS USING ESTIMATED FLOW:
STREET FLOW DEPTH(FEET) = 0.23
HALFSTREET FLOOD WIDTH(FEET) = 5.39
AVERAGE FLOW VELOCITY(FEET/SEC.) = 4.61
PRODUCT OF DEPTH&VELOCITY(FT*FT/SEC.) = 1.04
STREET FLOW TRAVEL TIME(MIN.) = 1.02 Tc(MIN.) = 6.62
100 YEAR RAINFALL INTENSITY(INCH/HOUR) = 6.378

*USER SPECIFIED(SUBAREA):
RESIDENTIAL (1. DU/AC OR LESS) RUNOFF COEFFICIENT = .6900
S.C.S. CURVE NUMBER (AMC II) = 0
AREA-AVERAGE RUNOFF COEFFICIENT = 0.690
SUBAREA AREA(ACRES) = 0.66 SUBAREA RUNOFF(CFS) = 2.90
TOTAL AREA(ACRES) = 0.7 PEAK FLOW RATE(CFS) = 3.17

END OF SUBAREA STREET FLOW HYDRAULICS:
DEPTH(FEET) = 0.26 HALFSTREET FLOOD WIDTH(FEET) = 7.45
FLOW VELOCITY(FEET/SEC.) = 5.14 DEPTH*VELOCITY(FT*FT/SEC.) = 1.35
LONGEST FLOWPATH FROM NODE 101.00 TO NODE 104.00 = 395.00 FEET.

FLOW PROCESS FROM NODE 104.00 TO NODE 105.00 IS CODE = 31

>>>>>COMPUTE PIPE-FLOW TRAVEL TIME THRU SUBAREA<<<<<
>>>>>USING COMPUTER-ESTIMATED PIPESIZE (NON-PRESSURE FLOW)<<<<<

=====

ELEVATION DATA: UPSTREAM(FEET) = 147.60 DOWNSTREAM(FEET) = 143.10
FLOW LENGTH(FEET) = 213.00 MANNING'S N = 0.013
DEPTH OF FLOW IN 12.0 INCH PIPE IS 6.9 INCHES
PIPE-FLOW VELOCITY(FEET/SEC.) = 6.79
ESTIMATED PIPE DIAMETER(INCH) = 12.00 NUMBER OF PIPES = 1
PIPE-FLOW(CFS) = 3.17
PIPE TRAVEL TIME(MIN.) = 0.52 Tc(MIN.) = 7.14
LONGEST FLOWPATH FROM NODE 101.00 TO NODE 105.00 = 608.00 FEET.

FLOW PROCESS FROM NODE 105.00 TO NODE 105.00 IS CODE = 81

>>>>ADDITION OF SUBAREA TO MAINLINE PEAK FLOW<<<<<

=====

100 YEAR RAINFALL INTENSITY(INCH/HOUR) = 6.072
*USER SPECIFIED(SUBAREA):
RESIDENTIAL (7.3 DU/AC OR LESS) RUNOFF COEFFICIENT = .6900
S.C.S. CURVE NUMBER (AMC II) = 0
AREA-AVERAGE RUNOFF COEFFICIENT = 0.6900
SUBAREA AREA(ACRES) = 0.91 SUBAREA RUNOFF(CFS) = 3.81
TOTAL AREA(ACRES) = 1.6 TOTAL RUNOFF(CFS) = 6.83
TC(MIN.) = 7.14

FLOW PROCESS FROM NODE 105.00 TO NODE 106.00 IS CODE = 31

>>>>COMPUTE PIPE-FLOW TRAVEL TIME THRU SUBAREA<<<<<
>>>>USING COMPUTER-ESTIMATED PIPESIZE (NON-PRESSURE FLOW)<<<<<

=====

ELEVATION DATA: UPSTREAM(FEET) = 143.10 DOWNSTREAM(FEET) = 139.50
FLOW LENGTH(FEET) = 214.00 MANNING'S N = 0.013
DEPTH OF FLOW IN 15.0 INCH PIPE IS 10.5 INCHES
PIPE-FLOW VELOCITY(FEET/SEC.) = 7.45
ESTIMATED PIPE DIAMETER(INCH) = 15.00 NUMBER OF PIPES = 1
PIPE-FLOW(CFS) = 6.83
PIPE TRAVEL TIME(MIN.) = 0.48 Tc(MIN.) = 7.62
LONGEST FLOWPATH FROM NODE 101.00 TO NODE 106.00 = 822.00 FEET.

FLOW PROCESS FROM NODE 107.00 TO NODE 107.00 IS CODE = 1

>>>>DESIGNATE INDEPENDENT STREAM FOR CONFLUENCE<<<<<

=====

TOTAL NUMBER OF STREAMS = 2
CONFLUENCE VALUES USED FOR INDEPENDENT STREAM 1 ARE:
TIME OF CONCENTRATION(MIN.) = 7.62
RAINFALL INTENSITY(INCH/HR) = 5.82
TOTAL STREAM AREA(ACRES) = 1.63
PEAK FLOW RATE(CFS) AT CONFLUENCE = 6.83

FLOW PROCESS FROM NODE 110.00 TO NODE 111.00 IS CODE = 21

>>>>RATIONAL METHOD INITIAL SUBAREA ANALYSIS<<<<<

=====

*USER SPECIFIED(SUBAREA):
RESIDENTIAL (7.3 DU/AC OR LESS) RUNOFF COEFFICIENT = .6900
S.C.S. CURVE NUMBER (AMC II) = 0
INITIAL SUBAREA FLOW-LENGTH(FEET) = 80.00
UPSTREAM ELEVATION(FEET) = 177.00

DOWNSTREAM ELEVATION(FEET) = 176.20
ELEVATION DIFFERENCE(FEET) = 0.80
SUBAREA OVERLAND TIME OF FLOW(MIN.) = 5.950
WARNING: INITIAL SUBAREA FLOW PATH LENGTH IS GREATER THAN
THE MAXIMUM OVERLAND FLOW LENGTH = 65.00
(Reference: Table 3-1B of Hydrology Manual)
THE MAXIMUM OVERLAND FLOW LENGTH IS USED IN Tc CALCULATION!
100 YEAR RAINFALL INTENSITY(INCH/HOUR) = 6.830
SUBAREA RUNOFF(CFS) = 0.28
TOTAL AREA(ACRES) = 0.06 TOTAL RUNOFF(CFS) = 0.28

FLOW PROCESS FROM NODE 111.00 TO NODE 112.00 IS CODE = 31

>>>>COMPUTE PIPE-FLOW TRAVEL TIME THRU SUBAREA<<<<<
>>>>USING COMPUTER-ESTIMATED PIPESIZE (NON-PRESSURE FLOW)<<<<<

=====

ELEVATION DATA: UPSTREAM(FEET) = 176.20 DOWNSTREAM(FEET) = 174.00
FLOW LENGTH(FEET) = 72.00 MANNING'S N = 0.013
DEPTH OF FLOW IN 6.0 INCH PIPE IS 2.2 INCHES
PIPE-FLOW VELOCITY(FEET/SEC.) = 4.27
ESTIMATED PIPE DIAMETER(INCH) = 6.00 NUMBER OF PIPES = 1
PIPE-FLOW(CFS) = 0.28
PIPE TRAVEL TIME(MIN.) = 0.28 Tc(MIN.) = 6.23
LONGEST FLOWPATH FROM NODE 110.00 TO NODE 112.00 = 152.00 FEET.

FLOW PROCESS FROM NODE 112.00 TO NODE 112.00 IS CODE = 81

>>>>ADDITION OF SUBAREA TO MAINLINE PEAK FLOW<<<<<

=====

100 YEAR RAINFALL INTENSITY(INCH/HOUR) = 6.630
*USER SPECIFIED(SUBAREA):
RESIDENTIAL (7.3 DU/AC OR LESS) RUNOFF COEFFICIENT = .6900
S.C.S. CURVE NUMBER (AMC II) = 0
AREA-AVERAGE RUNOFF COEFFICIENT = 0.6900
SUBAREA AREA(ACRES) = 0.07 SUBAREA RUNOFF(CFS) = 0.32
TOTAL AREA(ACRES) = 0.1 TOTAL RUNOFF(CFS) = 0.59
TC(MIN.) = 6.23

FLOW PROCESS FROM NODE 112.00 TO NODE 113.00 IS CODE = 62

>>>>COMPUTE STREET FLOW TRAVEL TIME THRU SUBAREA<<<<<
>>>>(STREET TABLE SECTION # 1 USED)<<<<<

=====

UPSTREAM ELEVATION(FEET) = 174.00 DOWNSTREAM ELEVATION(FEET) = 162.10
STREET LENGTH(FEET) = 163.00 CURB HEIGHT(INCHES) = 6.0
STREET HALFWIDTH(FEET) = 16.00

DISTANCE FROM CROWN TO CROSSFALL GRADEBREAK(FEET) = 11.00
INSIDE STREET CROSSFALL(DECIMAL) = 0.018
OUTSIDE STREET CROSSFALL(DECIMAL) = 0.018

SPECIFIED NUMBER OF HALFSTREETS CARRYING RUNOFF = 2
STREET PARKWAY CROSSFALL(DECIMAL) = 0.020
Manning's FRICTION FACTOR for Streetflow Section(curbs-to-curbs) = 0.0150
Manning's FRICTION FACTOR for Back-of-Walk Flow Section = 0.0200

**TRAVEL TIME COMPUTED USING ESTIMATED FLOW(CFS) = 2.29
STREETFLOW MODEL RESULTS USING ESTIMATED FLOW:
STREET FLOW DEPTH(FEET) = 0.20
HALFSTREET FLOOD WIDTH(FEET) = 4.07
AVERAGE FLOW VELOCITY(FEET/SEC.) = 4.27
PRODUCT OF DEPTH&VELOCITY(FT*FT/SEC.) = 0.86
STREET FLOW TRAVEL TIME(MIN.) = 0.64 Tc(MIN.) = 6.87
100 YEAR RAINFALL INTENSITY(INCH/HOUR) = 6.226

*USER SPECIFIED(SUBAREA):
RESIDENTIAL (7.3 DU/AC OR LESS) RUNOFF COEFFICIENT = .6900
S.C.S. CURVE NUMBER (AMC II) = 0
AREA-AVERAGE RUNOFF COEFFICIENT = 0.690
SUBAREA AREA(ACRES) = 0.79 SUBAREA RUNOFF(CFS) = 3.39
TOTAL AREA(ACRES) = 0.9 PEAK FLOW RATE(CFS) = 3.95

END OF SUBAREA STREET FLOW HYDRAULICS:
DEPTH(FEET) = 0.23 HALFSTREET FLOOD WIDTH(FEET) = 5.90
FLOW VELOCITY(FEET/SEC.) = 4.58 DEPTH*VELOCITY(FT*FT/SEC.) = 1.08
LONGEST FLOWPATH FROM NODE 110.00 TO NODE 113.00 = 315.00 FEET.

FLOW PROCESS FROM NODE 113.00 TO NODE 114.00 IS CODE = 31

>>>>COMPUTE PIPE-FLOW TRAVEL TIME THRU SUBAREA<<<<<
>>>>USING COMPUTER-ESTIMATED PIPESIZE (NON-PRESSURE FLOW)<<<<<

=====

ELEVATION DATA: UPSTREAM(FEET) = 162.10 DOWNSTREAM(FEET) = 139.60
FLOW LENGTH(FEET) = 226.00 MANNING'S N = 0.013
DEPTH OF FLOW IN 9.0 INCH PIPE IS 6.0 INCHES
PIPE-FLOW VELOCITY(FEET/SEC.) = 12.72
ESTIMATED PIPE DIAMETER(INCH) = 9.00 NUMBER OF PIPES = 1
PIPE-FLOW(CFS) = 3.95
PIPE TRAVEL TIME(MIN.) = 0.30 Tc(MIN.) = 7.16
LONGEST FLOWPATH FROM NODE 110.00 TO NODE 114.00 = 541.00 FEET.

FLOW PROCESS FROM NODE 114.00 TO NODE 114.00 IS CODE = 81

>>>>ADDITION OF SUBAREA TO MAINLINE PEAK FLOW<<<<<

=====

100 YEAR RAINFALL INTENSITY(INCH/HOUR) = 6.059

*USER SPECIFIED(SUBAREA):
 RESIDENTIAL (7.3 DU/AC OR LESS) RUNOFF COEFFICIENT = .6900
 S.C.S. CURVE NUMBER (AMC II) = 0
 AREA-AVERAGE RUNOFF COEFFICIENT = 0.6900
 SUBAREA AREA(ACRES) = 1.85 SUBAREA RUNOFF(CFS) = 7.73
 TOTAL AREA(ACRES) = 2.8 TOTAL RUNOFF(CFS) = 11.58
 TC(MIN.) = 7.16

 FLOW PROCESS FROM NODE 114.00 TO NODE 115.00 IS CODE = 31

>>>>COMPUTE PIPE-FLOW TRAVEL TIME THRU SUBAREA<<<<<
 >>>>USING COMPUTER-ESTIMATED PIPESIZE (NON-PRESSURE FLOW)<<<<<

=====

ELEVATION DATA: UPSTREAM(FEET) = 139.60 DOWNSTREAM(FEET) = 139.50
 FLOW LENGTH(FEET) = 20.00 MANNING'S N = 0.013
 DEPTH OF FLOW IN 24.0 INCH PIPE IS 15.4 INCHES
 PIPE-FLOW VELOCITY(FEET/SEC.) = 5.43
 ESTIMATED PIPE DIAMETER(INCH) = 24.00 NUMBER OF PIPES = 1
 PIPE-FLOW(CFS) = 11.58
 PIPE TRAVEL TIME(MIN.) = 0.06 Tc(MIN.) = 7.23
 LONGEST FLOWPATH FROM NODE 110.00 TO NODE 115.00 = 561.00 FEET.

 FLOW PROCESS FROM NODE 115.00 TO NODE 115.00 IS CODE = 1

>>>>DESIGNATE INDEPENDENT STREAM FOR CONFLUENCE<<<<<
 >>>>AND COMPUTE VARIOUS CONFLUENCED STREAM VALUES<<<<<

=====

TOTAL NUMBER OF STREAMS = 2
 CONFLUENCE VALUES USED FOR INDEPENDENT STREAM 2 ARE:
 TIME OF CONCENTRATION(MIN.) = 7.23
 RAINFALL INTENSITY(INCH/HR) = 6.03
 TOTAL STREAM AREA(ACRES) = 2.77
 PEAK FLOW RATE(CFS) AT CONFLUENCE = 11.58

** CONFLUENCE DATA **

STREAM NUMBER	RUNOFF (CFS)	Tc (MIN.)	INTENSITY (INCH/HOUR)	AREA (ACRE)
1	6.83	7.62	5.823	1.63
2	11.58	7.23	6.026	2.77

RAINFALL INTENSITY AND TIME OF CONCENTRATION RATIO
 CONFLUENCE FORMULA USED FOR 2 STREAMS.

** PEAK FLOW RATE TABLE **

STREAM NUMBER	RUNOFF (CFS)	Tc (MIN.)	INTENSITY (INCH/HOUR)
1	18.06	7.23	6.026
2	18.02	7.62	5.823

COMPUTED CONFLUENCE ESTIMATES ARE AS FOLLOWS:

PEAK FLOW RATE(CFS) = 18.06 Tc(MIN.) = 7.23
TOTAL AREA(ACRES) = 4.4
LONGEST FLOWPATH FROM NODE 101.00 TO NODE 115.00 = 822.00 FEET.

FLOW PROCESS FROM NODE 116.00 TO NODE 116.00 IS CODE = 81

>>>>ADDITION OF SUBAREA TO MAINLINE PEAK FLOW<<<<<

=====

100 YEAR RAINFALL INTENSITY(INCH/HOUR) = 6.026
*USER SPECIFIED(SUBAREA):
RESIDENTIAL (7.3 DU/AC OR LESS) RUNOFF COEFFICIENT = .6900
S.C.S. CURVE NUMBER (AMC II) = 0
AREA-AVERAGE RUNOFF COEFFICIENT = 0.6900
SUBAREA AREA(ACRES) = 0.30 SUBAREA RUNOFF(CFS) = 1.25
TOTAL AREA(ACRES) = 4.7 TOTAL RUNOFF(CFS) = 19.54
TC(MIN.) = 7.23

FLOW PROCESS FROM NODE 116.00 TO NODE 117.00 IS CODE = 31

>>>>COMPUTE PIPE-FLOW TRAVEL TIME THRU SUBAREA<<<<<
>>>>USING COMPUTER-ESTIMATED PIPESIZE (NON-PRESSURE FLOW)<<<<<

=====

ELEVATION DATA: UPSTREAM(FEET) = 134.40 DOWNSTREAM(FEET) = 133.00
FLOW LENGTH(FEET) = 96.00 MANNING'S N = 0.013
DEPTH OF FLOW IN 24.0 INCH PIPE IS 15.3 INCHES
PIPE-FLOW VELOCITY(FEET/SEC.) = 9.26
ESTIMATED PIPE DIAMETER(INCH) = 24.00 NUMBER OF PIPES = 1
PIPE-FLOW(CFS) = 19.54
PIPE TRAVEL TIME(MIN.) = 0.17 Tc(MIN.) = 7.40
LONGEST FLOWPATH FROM NODE 101.00 TO NODE 117.00 = 918.00 FEET.

FLOW PROCESS FROM NODE 117.00 TO NODE 117.00 IS CODE = 81

>>>>ADDITION OF SUBAREA TO MAINLINE PEAK FLOW<<<<<

=====

100 YEAR RAINFALL INTENSITY(INCH/HOUR) = 5.935
*USER SPECIFIED(SUBAREA):
RESIDENTIAL (7.3 DU/AC OR LESS) RUNOFF COEFFICIENT = .7700
S.C.S. CURVE NUMBER (AMC II) = 0
AREA-AVERAGE RUNOFF COEFFICIENT = 0.6988
SUBAREA AREA(ACRES) = 0.58 SUBAREA RUNOFF(CFS) = 2.65
TOTAL AREA(ACRES) = 5.3 TOTAL RUNOFF(CFS) = 21.90
TC(MIN.) = 7.40

=====

END OF STUDY SUMMARY:

TOTAL AREA(ACRES) = 5.3 TC(MIN.) = 7.40
PEAK FLOW RATE(CFS) = 21.90

=====
=====

END OF RATIONAL METHOD ANALYSIS



RATIONAL METHOD HYDROLOGY COMPUTER PROGRAM PACKAGE
Reference: SAN DIEGO COUNTY FLOOD CONTROL DISTRICT
2003,1985,1981 HYDROLOGY MANUAL

(c) Copyright 1982-2016 Advanced Engineering Software (aes)
Ver. 23.0 Release Date: 07/01/2016 License ID 1452

Analysis prepared by:

***** DESCRIPTION OF STUDY *****

- * PASCO LARET SUITER & ASSOC *
- * BASIN PR-2 (UNMIT) *
- * GUAJOME LAKE *

FILE NAME: PR23775.DAT
TIME/DATE OF STUDY: 15:00 08/15/2024

USER SPECIFIED HYDROLOGY AND HYDRAULIC MODEL INFORMATION:

2003 SAN DIEGO MANUAL CRITERIA

USER SPECIFIED STORM EVENT(YEAR) = 100.00
6-HOUR DURATION PRECIPITATION (INCHES) = 2.900
SPECIFIED MINIMUM PIPE SIZE(INCH) = 3.00
SPECIFIED PERCENT OF GRADIENTS(DECIMAL) TO USE FOR FRICTION SLOPE = 0.95
SAN DIEGO HYDROLOGY MANUAL "C"-VALUES USED FOR RATIONAL METHOD
NOTE: USE MODIFIED RATIONAL METHOD PROCEDURES FOR CONFLUENCE ANALYSIS

USER-DEFINED STREET-SECTIONS FOR COUPLED PIPEFLOW AND STREETFLOW MODEL

NO.	HALF- WIDTH (FT)	CROWN TO CROSSFALL (FT)	STREET-CROSSFALL: IN- / OUT-/ SIDE / SIDE/ WAY	CURB HEIGHT (FT)	GUTTER-GEOMETRIES: WIDTH (FT)	LIP (FT)	HIKE (FT)	MANNING FACTOR (n)
1	16.0	11.0	0.018/0.018/0.020	0.50	1.50	0.0312	0.125	0.0150

GLOBAL STREET FLOW-DEPTH CONSTRAINTS:

1. Relative Flow-Depth = 0.50 FEET
as (Maximum Allowable Street Flow Depth) - (Top-of-Curb)
2. (Depth)*(Velocity) Constraint = 6.0 (FT*FT/S)

*SIZE PIPE WITH A FLOW CAPACITY GREATER THAN
OR EQUAL TO THE UPSTREAM TRIBUTARY PIPE.*

FLOW PROCESS FROM NODE 201.00 TO NODE 202.00 IS CODE = 21

>>>>RATIONAL METHOD INITIAL SUBAREA ANALYSIS<<<<<

=====

*USER SPECIFIED(SUBAREA):

RESIDENTIAL (7.3 DU/AC OR LESS) RUNOFF COEFFICIENT = .7300

S.C.S. CURVE NUMBER (AMC II) = 0

INITIAL SUBAREA FLOW-LENGTH(FEET) = 50.00

UPSTREAM ELEVATION(FEET) = 177.60

DOWNSTREAM ELEVATION(FEET) = 177.10

ELEVATION DIFFERENCE(FEET) = 0.50

SUBAREA OVERLAND TIME OF FLOW(MIN.) = 4.709

100 YEAR RAINFALL INTENSITY(INCH/HOUR) = 7.641

NOTE: RAINFALL INTENSITY IS BASED ON Tc = 5-MINUTE.

SUBAREA RUNOFF(CFS) = 0.11

TOTAL AREA(ACRES) = 0.02 TOTAL RUNOFF(CFS) = 0.11

FLOW PROCESS FROM NODE 202.00 TO NODE 203.00 IS CODE = 31

>>>>COMPUTE PIPE-FLOW TRAVEL TIME THRU SUBAREA<<<<<

>>>>USING COMPUTER-ESTIMATED PIPESIZE (NON-PRESSURE FLOW)<<<<<

=====

ELEVATION DATA: UPSTREAM(FEET) = 177.10 DOWNSTREAM(FEET) = 176.00

FLOW LENGTH(FEET) = 45.00 MANNING'S N = 0.013

DEPTH OF FLOW IN 3.0 INCH PIPE IS 2.1 INCHES

PIPE-FLOW VELOCITY(FEET/SEC.) = 3.04

ESTIMATED PIPE DIAMETER(INCH) = 3.00 NUMBER OF PIPES = 1

PIPE-FLOW(CFS) = 0.11

PIPE TRAVEL TIME(MIN.) = 0.25 Tc(MIN.) = 4.96

LONGEST FLOWPATH FROM NODE 201.00 TO NODE 203.00 = 95.00 FEET.

FLOW PROCESS FROM NODE 203.00 TO NODE 203.00 IS CODE = 81

>>>>ADDITION OF SUBAREA TO MAINLINE PEAK FLOW<<<<<

=====

100 YEAR RAINFALL INTENSITY(INCH/HOUR) = 7.641

NOTE: RAINFALL INTENSITY IS BASED ON Tc = 5-MINUTE.

*USER SPECIFIED(SUBAREA):

RESIDENTIAL (7.3 DU/AC OR LESS) RUNOFF COEFFICIENT = .7300

S.C.S. CURVE NUMBER (AMC II) = 0

AREA-AVERAGE RUNOFF COEFFICIENT = 0.7300

SUBAREA AREA(ACRES) = 0.03 SUBAREA RUNOFF(CFS) = 0.17

TOTAL AREA(ACRES) = 0.0 TOTAL RUNOFF(CFS) = 0.28

TC(MIN.) = 4.96

FLOW PROCESS FROM NODE 203.00 TO NODE 204.00 IS CODE = 62

>>>>>COMPUTE STREET FLOW TRAVEL TIME THRU SUBAREA<<<<<<
>>>>>(STREET TABLE SECTION # 1 USED)<<<<<<

=====

UPSTREAM ELEVATION(FEET) = 176.00 DOWNSTREAM ELEVATION(FEET) = 172.20
STREET LENGTH(FEET) = 329.00 CURB HEIGHT(INCHES) = 6.0
STREET HALFWIDTH(FEET) = 16.00

DISTANCE FROM CROWN TO CROSSFALL GRADEBREAK(FEET) = 11.00
INSIDE STREET CROSSFALL(DECIMAL) = 0.018
OUTSIDE STREET CROSSFALL(DECIMAL) = 0.018

SPECIFIED NUMBER OF HALFSTREETS CARRYING RUNOFF = 1
STREET PARKWAY CROSSFALL(DECIMAL) = 0.020
Manning's FRICTION FACTOR for Streetflow Section(curbs-to-curbs) = 0.0150
Manning's FRICTION FACTOR for Back-of-Walk Flow Section = 0.0200

**TRAVEL TIME COMPUTED USING ESTIMATED FLOW(CFS) = 3.63
STREETFLOW MODEL RESULTS USING ESTIMATED FLOW:
STREET FLOW DEPTH(FEET) = 0.35
HALFSTREET FLOOD WIDTH(FEET) = 12.18
AVERAGE FLOW VELOCITY(FEET/SEC.) = 2.52
PRODUCT OF DEPTH&VELOCITY(FT*FT/SEC.) = 0.87
STREET FLOW TRAVEL TIME(MIN.) = 2.18 Tc(MIN.) = 7.14
100 YEAR RAINFALL INTENSITY(INCH/HOUR) = 6.074

*USER SPECIFIED(SUBAREA):
RESIDENTIAL (7.3 DU/AC OR LESS) RUNOFF COEFFICIENT = .7300
S.C.S. CURVE NUMBER (AMC II) = 0
AREA-AVERAGE RUNOFF COEFFICIENT = 0.730
SUBAREA AREA(ACRES) = 1.50 SUBAREA RUNOFF(CFS) = 6.65
TOTAL AREA(ACRES) = 1.5 PEAK FLOW RATE(CFS) = 6.87

END OF SUBAREA STREET FLOW HYDRAULICS:
DEPTH(FEET) = 0.41 HALFSTREET FLOOD WIDTH(FEET) = 15.79
FLOW VELOCITY(FEET/SEC.) = 2.93 DEPTH*VELOCITY(FT*FT/SEC.) = 1.21
LONGEST FLOWPATH FROM NODE 201.00 TO NODE 204.00 = 424.00 FEET.

FLOW PROCESS FROM NODE 204.00 TO NODE 205.00 IS CODE = 31

>>>>>COMPUTE PIPE-FLOW TRAVEL TIME THRU SUBAREA<<<<<<
>>>>>USING COMPUTER-ESTIMATED PIPESIZE (NON-PRESSURE FLOW)<<<<<<

=====

ELEVATION DATA: UPSTREAM(FEET) = 172.20 DOWNSTREAM(FEET) = 154.20
FLOW LENGTH(FEET) = 218.00 MANNING'S N = 0.013
DEPTH OF FLOW IN 12.0 INCH PIPE IS 7.3 INCHES
PIPE-FLOW VELOCITY(FEET/SEC.) = 13.70
ESTIMATED PIPE DIAMETER(INCH) = 12.00 NUMBER OF PIPES = 1
PIPE-FLOW(CFS) = 6.87
PIPE TRAVEL TIME(MIN.) = 0.27 Tc(MIN.) = 7.40
LONGEST FLOWPATH FROM NODE 201.00 TO NODE 205.00 = 642.00 FEET.

FLOW PROCESS FROM NODE 205.00 TO NODE 205.00 IS CODE = 81

>>>>ADDITION OF SUBAREA TO MAINLINE PEAK FLOW<<<<<

=====

100 YEAR RAINFALL INTENSITY(INCH/HOUR) = 5.933
*USER SPECIFIED(SUBAREA):
RESIDENTIAL (7.3 DU/AC OR LESS) RUNOFF COEFFICIENT = .7300
S.C.S. CURVE NUMBER (AMC II) = 0
AREA-AVERAGE RUNOFF COEFFICIENT = 0.7300
SUBAREA AREA(ACRES) = 1.16 SUBAREA RUNOFF(CFS) = 5.02
TOTAL AREA(ACRES) = 2.7 TOTAL RUNOFF(CFS) = 11.74
TC(MIN.) = 7.40

FLOW PROCESS FROM NODE 205.00 TO NODE 206.00 IS CODE = 31

>>>>COMPUTE PIPE-FLOW TRAVEL TIME THRU SUBAREA<<<<<
>>>>USING COMPUTER-ESTIMATED PIPESIZE (NON-PRESSURE FLOW)<<<<<

=====

ELEVATION DATA: UPSTREAM(FEET) = 154.20 DOWNSTREAM(FEET) = 154.00
FLOW LENGTH(FEET) = 20.00 MANNING'S N = 0.013
DEPTH OF FLOW IN 21.0 INCH PIPE IS 13.7 INCHES
PIPE-FLOW VELOCITY(FEET/SEC.) = 7.07
ESTIMATED PIPE DIAMETER(INCH) = 21.00 NUMBER OF PIPES = 1
PIPE-FLOW(CFS) = 11.74
PIPE TRAVEL TIME(MIN.) = 0.05 Tc(MIN.) = 7.45
LONGEST FLOWPATH FROM NODE 201.00 TO NODE 206.00 = 662.00 FEET.

FLOW PROCESS FROM NODE 206.00 TO NODE 206.00 IS CODE = 81

>>>>ADDITION OF SUBAREA TO MAINLINE PEAK FLOW<<<<<

=====

100 YEAR RAINFALL INTENSITY(INCH/HOUR) = 5.909
*USER SPECIFIED(SUBAREA):
RESIDENTIAL (7.3 DU/AC OR LESS) RUNOFF COEFFICIENT = .7300
S.C.S. CURVE NUMBER (AMC II) = 0
AREA-AVERAGE RUNOFF COEFFICIENT = 0.7300
SUBAREA AREA(ACRES) = 0.14 SUBAREA RUNOFF(CFS) = 0.60
TOTAL AREA(ACRES) = 2.9 TOTAL RUNOFF(CFS) = 12.29
TC(MIN.) = 7.45

FLOW PROCESS FROM NODE 207.00 TO NODE 208.00 IS CODE = 31

>>>>COMPUTE PIPE-FLOW TRAVEL TIME THRU SUBAREA<<<<<
>>>>USING COMPUTER-ESTIMATED PIPESIZE (NON-PRESSURE FLOW)<<<<<

=====

ELEVATION DATA: UPSTREAM(FEET) = 148.90 DOWNSTREAM(FEET) = 135.20
FLOW LENGTH(FEET) = 97.00 MANNING'S N = 0.013
DEPTH OF FLOW IN 12.0 INCH PIPE IS 9.3 INCHES
PIPE-FLOW VELOCITY(FEET/SEC.) = 18.89
ESTIMATED PIPE DIAMETER(INCH) = 12.00 NUMBER OF PIPES = 1
PIPE-FLOW(CFS) = 12.29
PIPE TRAVEL TIME(MIN.) = 0.09 Tc(MIN.) = 7.53
LONGEST FLOWPATH FROM NODE 201.00 TO NODE 208.00 = 759.00 FEET.

FLOW PROCESS FROM NODE 208.00 TO NODE 208.00 IS CODE = 1

>>>>DESIGNATE INDEPENDENT STREAM FOR CONFLUENCE<<<<<

=====

TOTAL NUMBER OF STREAMS = 2
CONFLUENCE VALUES USED FOR INDEPENDENT STREAM 1 ARE:
TIME OF CONCENTRATION(MIN.) = 7.53
RAINFALL INTENSITY(INCH/HR) = 5.87
TOTAL STREAM AREA(ACRES) = 2.85
PEAK FLOW RATE(CFS) AT CONFLUENCE = 12.29

FLOW PROCESS FROM NODE 301.00 TO NODE 302.00 IS CODE = 21

>>>>RATIONAL METHOD INITIAL SUBAREA ANALYSIS<<<<<

=====

*USER SPECIFIED(SUBAREA):
RESIDENTIAL (7.3 DU/AC OR LESS) RUNOFF COEFFICIENT = .6200
S.C.S. CURVE NUMBER (AMC II) = 0
INITIAL SUBAREA FLOW-LENGTH(FEET) = 50.00
UPSTREAM ELEVATION(FEET) = 179.00
DOWNSTREAM ELEVATION(FEET) = 178.50
ELEVATION DIFFERENCE(FEET) = 0.50
SUBAREA OVERLAND TIME OF FLOW(MIN.) = 6.109
100 YEAR RAINFALL INTENSITY(INCH/HOUR) = 6.714
SUBAREA RUNOFF(CFS) = 0.12
TOTAL AREA(ACRES) = 0.03 TOTAL RUNOFF(CFS) = 0.12

FLOW PROCESS FROM NODE 302.00 TO NODE 303.00 IS CODE = 31

>>>>COMPUTE PIPE-FLOW TRAVEL TIME THRU SUBAREA<<<<<
>>>>USING COMPUTER-ESTIMATED PIPESIZE (NON-PRESSURE FLOW)<<<<<

=====

ELEVATION DATA: UPSTREAM(FEET) = 178.50 DOWNSTREAM(FEET) = 177.30
FLOW LENGTH(FEET) = 48.00 MANNING'S N = 0.013
DEPTH OF FLOW IN 3.0 INCH PIPE IS 2.3 INCHES
PIPE-FLOW VELOCITY(FEET/SEC.) = 3.11
ESTIMATED PIPE DIAMETER(INCH) = 3.00 NUMBER OF PIPES = 1
PIPE-FLOW(CFS) = 0.12

PIPE TRAVEL TIME(MIN.) = 0.26 Tc(MIN.) = 6.37
LONGEST FLOWPATH FROM NODE 301.00 TO NODE 303.00 = 98.00 FEET.

FLOW PROCESS FROM NODE 303.00 TO NODE 303.00 IS CODE = 81

>>>>>ADDITION OF SUBAREA TO MAINLINE PEAK FLOW<<<<<

=====

100 YEAR RAINFALL INTENSITY(INCH/HOUR) = 6.538
*USER SPECIFIED(SUBAREA):
RESIDENTIAL (7.3 DU/AC OR LESS) RUNOFF COEFFICIENT = .6200
S.C.S. CURVE NUMBER (AMC II) = 0
AREA-AVERAGE RUNOFF COEFFICIENT = 0.6200
SUBAREA AREA(ACRES) = 0.03 SUBAREA RUNOFF(CFS) = 0.12
TOTAL AREA(ACRES) = 0.1 TOTAL RUNOFF(CFS) = 0.24
TC(MIN.) = 6.37

FLOW PROCESS FROM NODE 303.00 TO NODE 304.00 IS CODE = 62

>>>>>COMPUTE STREET FLOW TRAVEL TIME THRU SUBAREA<<<<<
>>>>>(STREET TABLE SECTION # 1 USED)<<<<<

=====

UPSTREAM ELEVATION(FEET) = 177.30 DOWNSTREAM ELEVATION(FEET) = 175.60
STREET LENGTH(FEET) = 128.00 CURB HEIGHT(INCHES) = 6.0
STREET HALFWIDTH(FEET) = 16.00

DISTANCE FROM CROWN TO CROSSFALL GRADEBREAK(FEET) = 11.00
INSIDE STREET CROSSFALL(DECIMAL) = 0.018
OUTSIDE STREET CROSSFALL(DECIMAL) = 0.018

SPECIFIED NUMBER OF HALFSTREETS CARRYING RUNOFF = 1
STREET PARKWAY CROSSFALL(DECIMAL) = 0.020
Manning's FRICTION FACTOR for Streetflow Section(curbs-to-curbs) = 0.0150
Manning's FRICTION FACTOR for Back-of-Walk Flow Section = 0.0200

**TRAVEL TIME COMPUTED USING ESTIMATED FLOW(CFS) = 1.20
STREETFLOW MODEL RESULTS USING ESTIMATED FLOW:
STREET FLOW DEPTH(FEET) = 0.26
HALFSTREET FLOOD WIDTH(FEET) = 7.19
AVERAGE FLOW VELOCITY(FEET/SEC.) = 2.06
PRODUCT OF DEPTH&VELOCITY(FT*FT/SEC.) = 0.53
STREET FLOW TRAVEL TIME(MIN.) = 1.03 Tc(MIN.) = 7.40
100 YEAR RAINFALL INTENSITY(INCH/HOUR) = 5.933
*USER SPECIFIED(SUBAREA):
RESIDENTIAL (7.3 DU/AC OR LESS) RUNOFF COEFFICIENT = .6200
S.C.S. CURVE NUMBER (AMC II) = 0
AREA-AVERAGE RUNOFF COEFFICIENT = 0.620
SUBAREA AREA(ACRES) = 0.52 SUBAREA RUNOFF(CFS) = 1.91
TOTAL AREA(ACRES) = 0.6 PEAK FLOW RATE(CFS) = 2.13

END OF SUBAREA STREET FLOW HYDRAULICS:

DEPTH(FEET) = 0.30 HALFSTREET FLOOD WIDTH(FEET) = 9.43
FLOW VELOCITY(FEET/SEC.) = 2.33 DEPTH*VELOCITY(FT*FT/SEC.) = 0.70
LONGEST FLOWPATH FROM NODE 301.00 TO NODE 304.00 = 226.00 FEET.

FLOW PROCESS FROM NODE 304.00 TO NODE 305.00 IS CODE = 31

>>>>COMPUTE PIPE-FLOW TRAVEL TIME THRU SUBAREA<<<<<
>>>>USING COMPUTER-ESTIMATED PIPESIZE (NON-PRESSURE FLOW)<<<<<

=====

ELEVATION DATA: UPSTREAM(FEET) = 175.60 DOWNSTREAM(FEET) = 168.90
FLOW LENGTH(FEET) = 173.00 MANNING'S N = 0.013
DEPTH OF FLOW IN 9.0 INCH PIPE IS 5.4 INCHES
PIPE-FLOW VELOCITY(FEET/SEC.) = 7.70
ESTIMATED PIPE DIAMETER(INCH) = 9.00 NUMBER OF PIPES = 1
PIPE-FLOW(CFS) = 2.13
PIPE TRAVEL TIME(MIN.) = 0.37 Tc(MIN.) = 7.78
LONGEST FLOWPATH FROM NODE 301.00 TO NODE 305.00 = 399.00 FEET.

FLOW PROCESS FROM NODE 305.00 TO NODE 306.00 IS CODE = 31

>>>>COMPUTE PIPE-FLOW TRAVEL TIME THRU SUBAREA<<<<<
>>>>USING COMPUTER-ESTIMATED PIPESIZE (NON-PRESSURE FLOW)<<<<<

=====

ELEVATION DATA: UPSTREAM(FEET) = 168.90 DOWNSTREAM(FEET) = 164.50
FLOW LENGTH(FEET) = 100.00 MANNING'S N = 0.013
DEPTH OF FLOW IN 9.0 INCH PIPE IS 5.2 INCHES
PIPE-FLOW VELOCITY(FEET/SEC.) = 8.09
ESTIMATED PIPE DIAMETER(INCH) = 9.00 NUMBER OF PIPES = 1
PIPE-FLOW(CFS) = 2.13
PIPE TRAVEL TIME(MIN.) = 0.21 Tc(MIN.) = 7.98
LONGEST FLOWPATH FROM NODE 301.00 TO NODE 306.00 = 499.00 FEET.

FLOW PROCESS FROM NODE 306.00 TO NODE 306.00 IS CODE = 81

>>>>ADDITION OF SUBAREA TO MAINLINE PEAK FLOW<<<<<

=====

100 YEAR RAINFALL INTENSITY(INCH/HOUR) = 5.651
*USER SPECIFIED(SUBAREA):
RESIDENTIAL (7.3 DU/AC OR LESS) RUNOFF COEFFICIENT = .6200
S.C.S. CURVE NUMBER (AMC II) = 0
AREA-AVERAGE RUNOFF COEFFICIENT = 0.6200
SUBAREA AREA(ACRES) = 0.49 SUBAREA RUNOFF(CFS) = 1.72
TOTAL AREA(ACRES) = 1.1 TOTAL RUNOFF(CFS) = 3.75
TC(MIN.) = 7.98

FLOW PROCESS FROM NODE 307.00 TO NODE 308.00 IS CODE = 31

>>>>COMPUTE PIPE-FLOW TRAVEL TIME THRU SUBAREA<<<<<
>>>>USING COMPUTER-ESTIMATED PIPESIZE (NON-PRESSURE FLOW)<<<<<

=====

ELEVATION DATA: UPSTREAM(FEET) =	160.40	DOWNSTREAM(FEET) =	146.20
FLOW LENGTH(FEET) =	182.00	MANNING'S N =	0.013
DEPTH OF FLOW IN	9.0 INCH PIPE IS	6.3 INCHES	
PIPE-FLOW VELOCITY(FEET/SEC.) =	11.39		
ESTIMATED PIPE DIAMETER(INCH) =	9.00	NUMBER OF PIPES =	1
PIPE-FLOW(CFS) =	3.75		
PIPE TRAVEL TIME(MIN.) =	0.27	Tc(MIN.) =	8.25
LONGEST FLOWPATH FROM NODE	301.00 TO NODE	308.00 =	681.00 FEET.

FLOW PROCESS FROM NODE 308.00 TO NODE 309.00 IS CODE = 31

>>>>COMPUTE PIPE-FLOW TRAVEL TIME THRU SUBAREA<<<<<
>>>>USING COMPUTER-ESTIMATED PIPESIZE (NON-PRESSURE FLOW)<<<<<

=====

ELEVATION DATA: UPSTREAM(FEET) =	146.20	DOWNSTREAM(FEET) =	144.80
FLOW LENGTH(FEET) =	194.00	MANNING'S N =	0.013
DEPTH OF FLOW IN	15.0 INCH PIPE IS	9.3 INCHES	
PIPE-FLOW VELOCITY(FEET/SEC.) =	4.72		
ESTIMATED PIPE DIAMETER(INCH) =	15.00	NUMBER OF PIPES =	1
PIPE-FLOW(CFS) =	3.75		
PIPE TRAVEL TIME(MIN.) =	0.69	Tc(MIN.) =	8.93
LONGEST FLOWPATH FROM NODE	301.00 TO NODE	309.00 =	875.00 FEET.

FLOW PROCESS FROM NODE 309.00 TO NODE 310.00 IS CODE = 31

>>>>COMPUTE PIPE-FLOW TRAVEL TIME THRU SUBAREA<<<<<
>>>>USING COMPUTER-ESTIMATED PIPESIZE (NON-PRESSURE FLOW)<<<<<

=====

ELEVATION DATA: UPSTREAM(FEET) =	144.80	DOWNSTREAM(FEET) =	135.20
FLOW LENGTH(FEET) =	184.00	MANNING'S N =	0.013
DEPTH OF FLOW IN	12.0 INCH PIPE IS	5.8 INCHES	
PIPE-FLOW VELOCITY(FEET/SEC.) =	9.95		
ESTIMATED PIPE DIAMETER(INCH) =	12.00	NUMBER OF PIPES =	1
PIPE-FLOW(CFS) =	3.75		
PIPE TRAVEL TIME(MIN.) =	0.31	Tc(MIN.) =	9.24
LONGEST FLOWPATH FROM NODE	301.00 TO NODE	310.00 =	1059.00 FEET.

FLOW PROCESS FROM NODE 310.00 TO NODE 310.00 IS CODE = 1

>>>>DESIGNATE INDEPENDENT STREAM FOR CONFLUENCE<<<<<
>>>>AND COMPUTE VARIOUS CONFLUENCED STREAM VALUES<<<<<

```

=====
TOTAL NUMBER OF STREAMS = 2
CONFLUENCE VALUES USED FOR INDEPENDENT STREAM 2 ARE:
TIME OF CONCENTRATION(MIN.) = 9.24
RAINFALL INTENSITY(INCH/HR) = 5.14
TOTAL STREAM AREA(ACRES) = 1.07
PEAK FLOW RATE(CFS) AT CONFLUENCE = 3.75

```

** CONFLUENCE DATA **

STREAM NUMBER	RUNOFF (CFS)	Tc (MIN.)	INTENSITY (INCH/HOUR)	AREA (ACRE)
1	12.29	7.53	5.865	2.85
2	3.75	9.24	5.141	1.07

RAINFALL INTENSITY AND TIME OF CONCENTRATION RATIO
CONFLUENCE FORMULA USED FOR 2 STREAMS.

** PEAK FLOW RATE TABLE **

STREAM NUMBER	RUNOFF (CFS)	Tc (MIN.)	INTENSITY (INCH/HOUR)
1	15.35	7.53	5.865
2	14.52	9.24	5.141

COMPUTED CONFLUENCE ESTIMATES ARE AS FOLLOWS:

```

PEAK FLOW RATE(CFS) = 15.35 Tc(MIN.) = 7.53
TOTAL AREA(ACRES) = 3.9
LONGEST FLOWPATH FROM NODE 301.00 TO NODE 310.00 = 1059.00 FEET.

```

```

FLOW PROCESS FROM NODE 310.00 TO NODE 311.00 IS CODE = 31

```

```

-----
>>>>>COMPUTE PIPE-FLOW TRAVEL TIME THRU SUBAREA<<<<<
>>>>>USING COMPUTER-ESTIMATED PIPESIZE (NON-PRESSURE FLOW)<<<<<

```

```

=====
ELEVATION DATA: UPSTREAM(FEET) = 135.20 DOWNSTREAM(FEET) = 135.00
FLOW LENGTH(FEET) = 44.00 MANNING'S N = 0.013
DEPTH OF FLOW IN 27.0 INCH PIPE IS 17.5 INCHES
PIPE-FLOW VELOCITY(FEET/SEC.) = 5.62
ESTIMATED PIPE DIAMETER(INCH) = 27.00 NUMBER OF PIPES = 1
PIPE-FLOW(CFS) = 15.35
PIPE TRAVEL TIME(MIN.) = 0.13 Tc(MIN.) = 7.66
LONGEST FLOWPATH FROM NODE 301.00 TO NODE 311.00 = 1103.00 FEET.

```

```

FLOW PROCESS FROM NODE 311.00 TO NODE 311.00 IS CODE = 81

```

```

-----
>>>>>ADDITION OF SUBAREA TO MAINLINE PEAK FLOW<<<<<

```

```

=====
100 YEAR RAINFALL INTENSITY(INCH/HOUR) = 5.801
*USER SPECIFIED(SUBAREA):

```

RESIDENTIAL (7.3 DU/AC OR LESS) RUNOFF COEFFICIENT = .7000
S.C.S. CURVE NUMBER (AMC II) = 0
AREA-AVERAGE RUNOFF COEFFICIENT = 0.7000
SUBAREA AREA(ACRES) = 0.84 SUBAREA RUNOFF(CFS) = 3.41
TOTAL AREA(ACRES) = 4.8 TOTAL RUNOFF(CFS) = 19.33
TC(MIN.) = 7.66

=====

END OF STUDY SUMMARY:

TOTAL AREA(ACRES) = 4.8 TC(MIN.) = 7.66
PEAK FLOW RATE(CFS) = 19.33

=====

=====

END OF RATIONAL METHOD ANALYSIS



Appendix B

Storm Water Pollutant Control and Detention Calculations

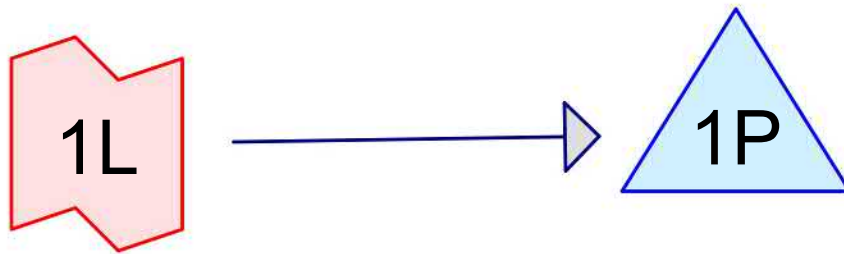

BMP-1 Inflow
Hydrograph

BMP-1 100-YR ALT2

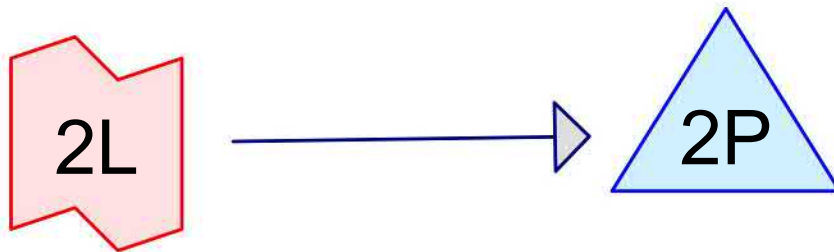

BMP-2 Inflow
Hydrograph

BMP-2 100-YR

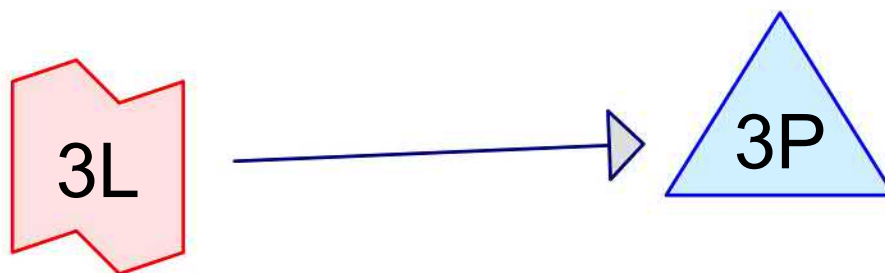

BMP-3 Inflow
Hydrograph

BMP-3 100-YR

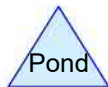

Routing Diagram for 3775

Prepared by Pasco Laret Suiter & Assoc, Printed 8/14/2024
HydroCAD® 10.20-5b s/n 10097 © 2023 HydroCAD Software Solutions LLC

Summary for Link 1L: BMP-1 Inflow Hydrograph

Inflow = 19.54 cfs @ 4.08 hrs, Volume= 0.779 af
Primary = 19.54 cfs @ 4.08 hrs, Volume= 0.779 af, Atten= 0%, Lag= 0.0 min
Routed to Pond 1P : BMP-1 100-YR ALT2

Primary outflow = Inflow, Time Span= 0.00-96.00 hrs, dt= 0.001 hrs

DISCHARGE Imported from BMP-1 RatHydro adj.csv

Link 1L: BMP-1 Inflow Hydrograph

Hydrograph

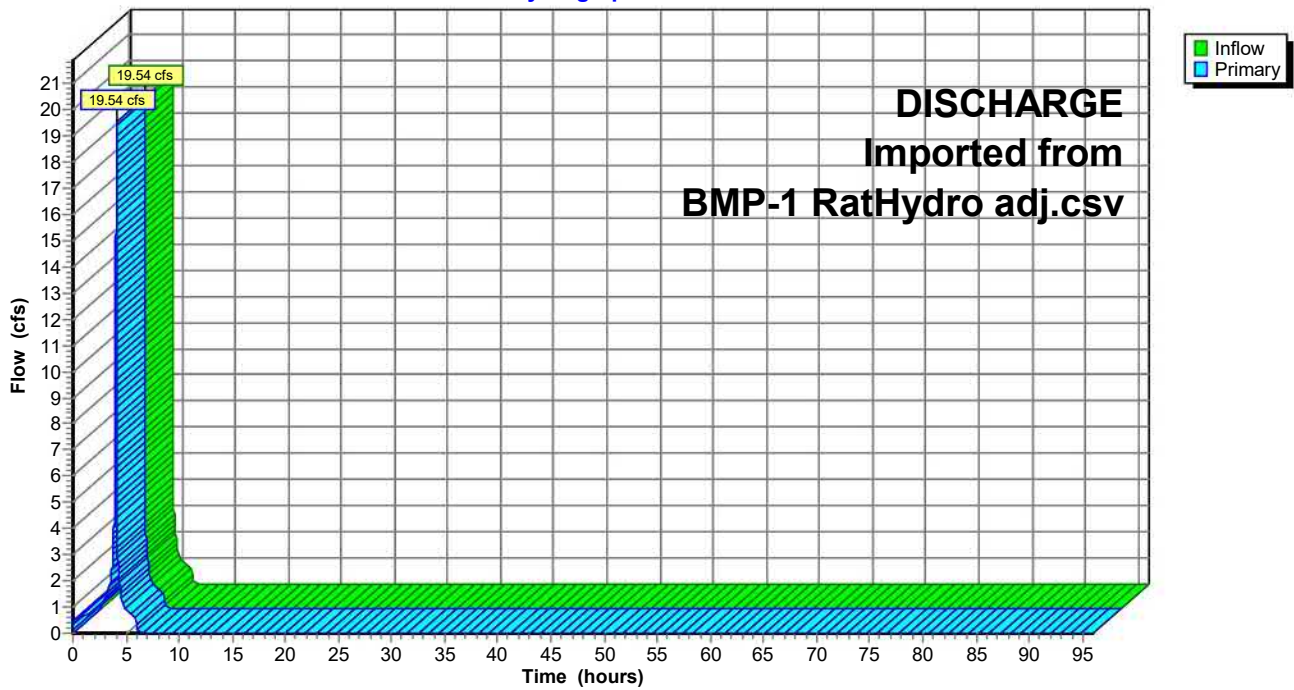

Summary for Pond 1P: BMP-1 100-YR ALT2

Inflow = 19.54 cfs @ 4.08 hrs, Volume= 0.779 af
 Outflow = 5.85 cfs @ 4.18 hrs, Volume= 0.779 af, Atten= 70%, Lag= 5.9 min
 Primary = 5.85 cfs @ 4.18 hrs, Volume= 0.779 af

Routing by Dyn-Stor-Ind method, Time Span= 0.00-96.00 hrs, dt= 0.001 hrs
 Peak Elev= 101.67' @ 4.18 hrs Surf.Area= 8,045 sf Storage= 9,401 cf

Plug-Flow detention time= 19.6 min calculated for 0.779 af (100% of inflow)
 Center-of-Mass det. time= 19.6 min (231.5 - 211.8)

Volume	Invert	Avail.Storage	Storage Description			
#1	100.50'	12,068 cf	Biofiltration Basin (Conic) Listed below (Recalc)			
Elevation (feet)	Surf.Area (sq-ft)	Voids (%)	Inc.Store (cubic-feet)	Cum.Store (cubic-feet)	Wet.Area (sq-ft)	
100.50	8,045	0.0	0	0	8,045	
102.00	8,045	100.0	12,068	12,068	8,522	

Device	Routing	Invert	Outlet Devices
#1	Primary	95.00'	18.00" Round Outlet L= 10.0' RCP, square edge headwall, Ke= 0.500 Inlet / Outlet Invert= 95.00' / 94.90' S= 0.0100 '/' Cc= 0.900 n= 0.013, Flow Area= 1.77 sf
#2	Device 1	100.50'	21.00" W x 2.00" H Vert. Orifice X 4.00 C= 0.600 Limited to weir flow at low heads
#3	Device 1	101.67'	36.00" x 36.00" Horiz. Grate C= 0.600 in 36.00" x 36.00" Grate (100% open area) Limited to weir flow at low heads
#4	Device 1	101.67'	36.00" x 36.00" Horiz. Grate C= 0.600 in 36.00" x 36.00" Grate (100% open area) Limited to weir flow at low heads
#5	Device 1	101.67'	36.00" x 36.00" Horiz. Grate C= 0.600 in 36.00" x 36.00" Grate (100% open area) Limited to weir flow at low heads
#6	Device 1	101.67'	36.00" x 36.00" Horiz. Grate C= 0.600 in 36.00" x 36.00" Grate (100% open area) Limited to weir flow at low heads
#7	Device 1	101.67'	36.00" x 36.00" Horiz. Grate C= 0.600 in 36.00" x 36.00" Grate (100% open area) Limited to weir flow at low heads
#8	Device 1	101.67'	36.00" x 36.00" Horiz. Grate C= 0.600 in 36.00" x 36.00" Grate (100% open area) Limited to weir flow at low heads
#9	Device 1	101.67'	18.00" x 18.00" Horiz. Grate C= 0.600 in 18.00" x 18.00" Grate (100% open area) Limited to weir flow at low heads

Primary OutFlow Max=5.85 cfs @ 4.18 hrs HW=101.67' (Free Discharge)

1=Outlet (Passes 5.85 cfs of 20.70 cfs potential flow)

2=Orifice (Orifice Controls 5.85 cfs @ 5.01 fps)

3=Grate (Controls 0.00 cfs)

4=Grate (Controls 0.00 cfs)

5=Grate (Controls 0.00 cfs)

6=Grate (Controls 0.00 cfs)

7=Grate (Controls 0.00 cfs)

8=Grate (Controls 0.00 cfs)

9=Grate (Controls 0.00 cfs)

Pond 1P: BMP-1 100-YR ALT2

Hydrograph

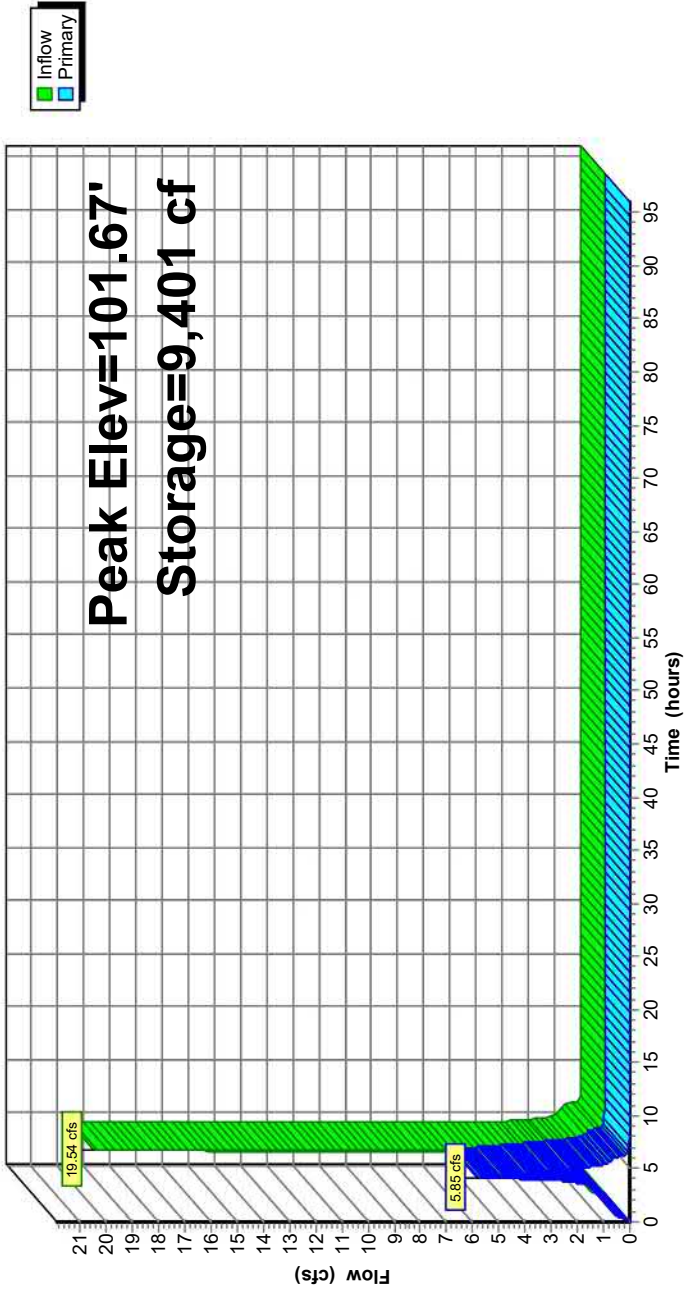

Summary for Link 2L: BMP-2 Inflow Hydrograph

Inflow = 12.29 cfs @ 4.08 hrs, Volume= 0.497 af
Primary = 12.29 cfs @ 4.08 hrs, Volume= 0.497 af, Atten= 0%, Lag= 0.0 min
Routed to Pond 2P : BMP-2 100-YR

Primary outflow = Inflow, Time Span= 0.00-96.00 hrs, dt= 0.001 hrs

DISCHARGE Imported from BMP-2 RatHydro adj.csv

Link 2L: BMP-2 Inflow Hydrograph

Hydrograph

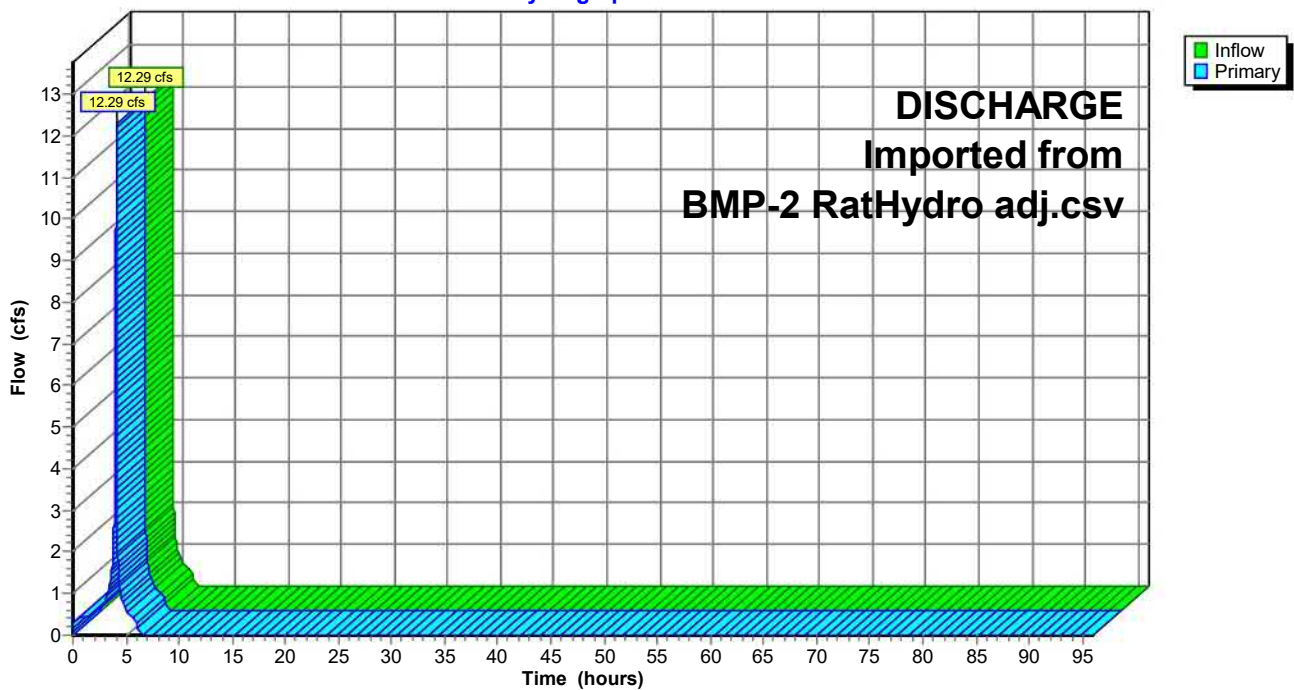

Summary for Pond 2P: BMP-2 100-YR

Inflow = 12.29 cfs @ 4.08 hrs, Volume= 0.497 af
 Outflow = 5.21 cfs @ 4.16 hrs, Volume= 0.497 af, Atten= 58%, Lag= 4.8 min
 Primary = 5.21 cfs @ 4.16 hrs, Volume= 0.497 af

Routing by Dyn-Stor-Ind method, Time Span= 0.00-96.00 hrs, dt= 0.001 hrs
 Peak Elev= 102.05' @ 4.16 hrs Surf.Area= 4,500 sf Storage= 4,731 cf

Plug-Flow detention time= 14.0 min calculated for 0.497 af (100% of inflow)
 Center-of-Mass det. time= 14.0 min (225.8 - 211.8)

Volume	Invert	Avail.Storage	Storage Description			
#1	101.00'	7,875 cf	Biofiltration Basin (Conic) Listed below (Recalc)			
Elevation (feet)	Surf.Area (sq-ft)	Voids (%)	Inc.Store (cubic-feet)	Cum.Store (cubic-feet)	Wet.Area (sq-ft)	
101.00	4,500	0.0	0	0	4,500	
102.75	4,500	100.0	7,875	7,875	4,916	

Device	Routing	Invert	Outlet Devices
#1	Primary	95.00'	18.00" Round Outlet L= 10.0' RCP, square edge headwall, Ke= 0.500 Inlet / Outlet Invert= 95.00' / 94.90' S= 0.0100 '/' Cc= 0.900 n= 0.013, Flow Area= 1.77 sf
#2	Device 1	101.00'	18.00" W x 3.00" H Vert. Orifice X 3.00 C= 0.600 Limited to weir flow at low heads
#3	Device 1	102.15'	36.00" x 36.00" Horiz. Grate C= 0.600 in 36.00" x 36.00" Grate (100% open area) Limited to weir flow at low heads
#4	Device 1	102.15'	36.00" x 36.00" Horiz. Grate C= 0.600 in 36.00" x 36.00" Grate (100% open area) Limited to weir flow at low heads

Primary OutFlow Max=5.21 cfs @ 4.16 hrs HW=102.05' (Free Discharge)

- 1=Outlet (Passes 5.21 cfs of 21.36 cfs potential flow)
- 2=Orifice (Orifice Controls 5.21 cfs @ 4.63 fps)
- 3=Grate (Controls 0.00 cfs)
- 4=Grate (Controls 0.00 cfs)

Pond 2P: BMP-2 100-YR

Hydrograph

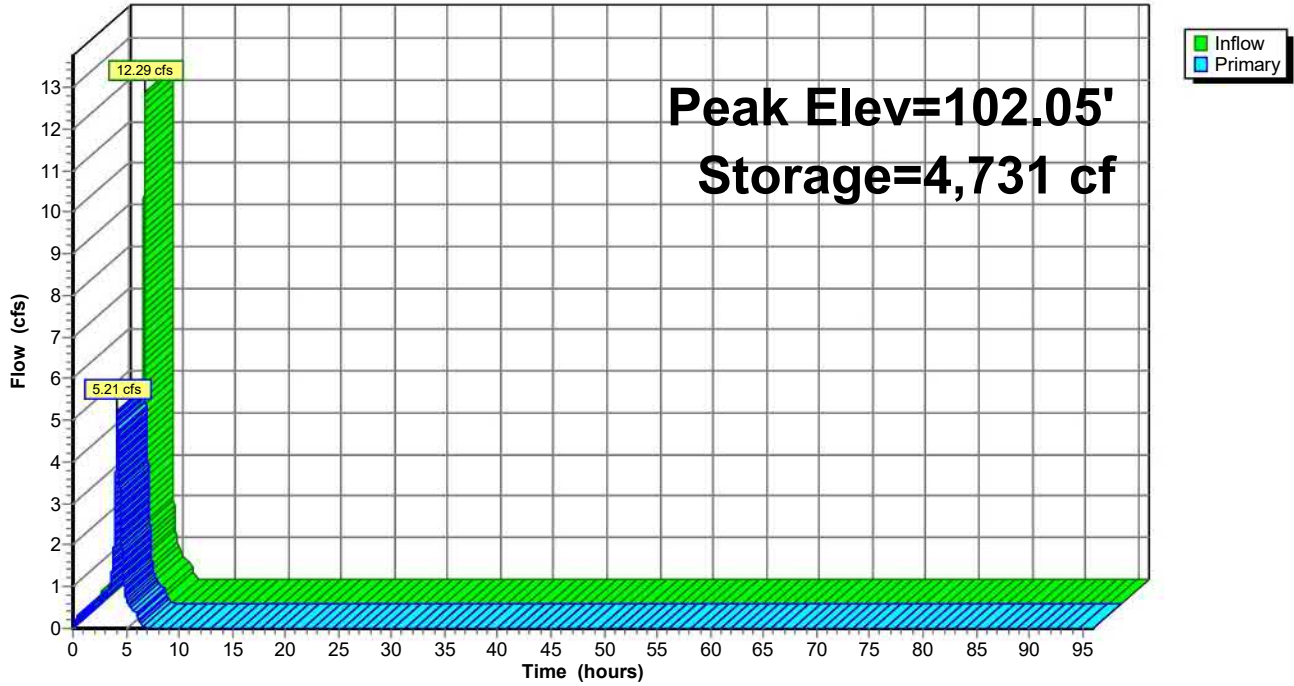

Summary for Link 3L: BMP-3 Inflow Hydrograph

Inflow = 3.75 cfs @ 4.13 hrs, Volume= 0.155 af
Primary = 3.75 cfs @ 4.13 hrs, Volume= 0.155 af, Atten= 0%, Lag= 0.0 min
Routed to Pond 3P : BMP-3 100-YR

Primary outflow = Inflow, Time Span= 0.00-96.00 hrs, dt= 0.001 hrs

DISCHARGE Imported from BMP-3 RatHydro adj.csv

Link 3L: BMP-3 Inflow Hydrograph

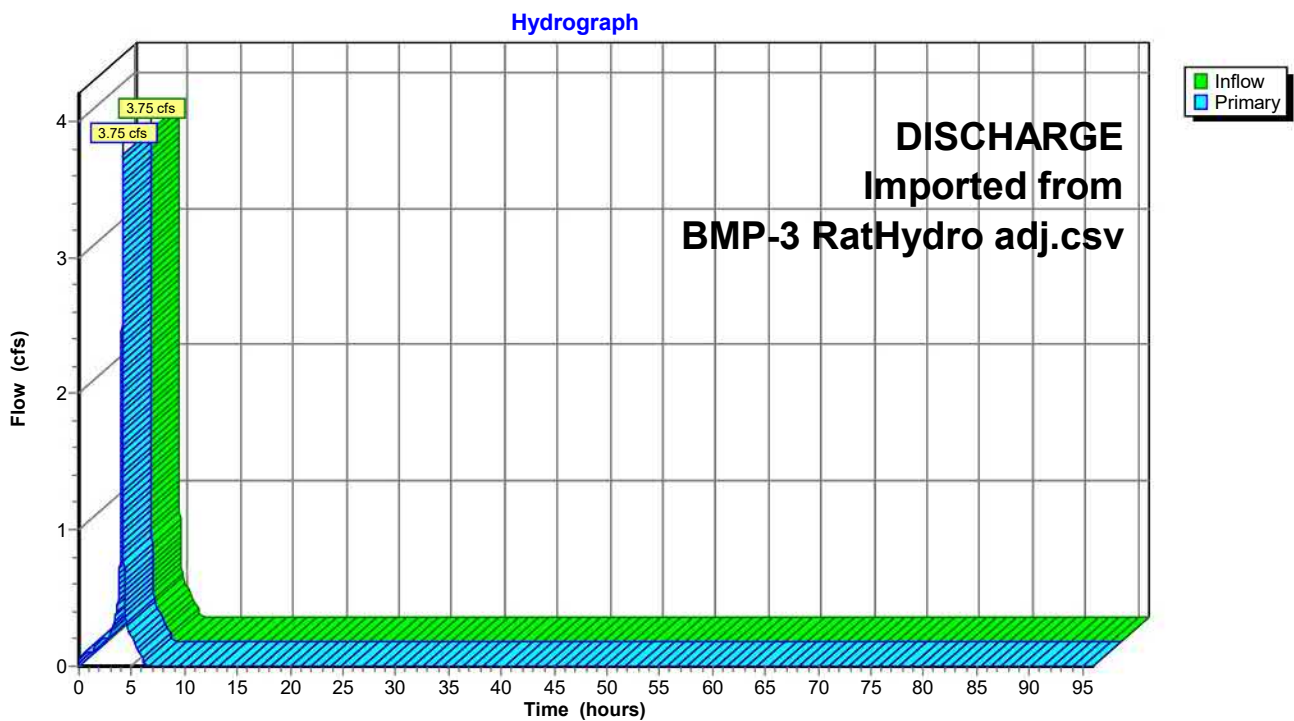

Summary for Pond 3P: BMP-3 100-YR

Inflow = 3.75 cfs @ 4.13 hrs, Volume= 0.155 af
 Outflow = 0.83 cfs @ 4.26 hrs, Volume= 0.155 af, Atten= 78%, Lag= 7.4 min
 Primary = 0.83 cfs @ 4.26 hrs, Volume= 0.155 af

Routing by Dyn-Stor-Ind method, Time Span= 0.00-96.00 hrs, dt= 0.001 hrs
 Peak Elev= 102.03' @ 4.26 hrs Surf.Area= 1,840 sf Storage= 2,332 cf

Plug-Flow detention time= 32.4 min calculated for 0.155 af (100% of inflow)
 Center-of-Mass det. time= 32.4 min (248.8 - 216.4)

Volume	Invert	Avail.Storage	Storage Description			
#1	100.50'	4,334 cf	Biofiltration Basin (Conic) Listed below (Recalc)			
Elevation (feet)	Surf.Area (sq-ft)	Voids (%)	Inc.Store (cubic-feet)	Cum.Store (cubic-feet)	Wet.Area (sq-ft)	
100.50	1,231	0.0	0	0	1,231	
103.00	2,291	100.0	4,334	4,334	2,353	

Device	Routing	Invert	Outlet Devices	
#1	Primary	96.00'	18.00" Round Outlet L= 10.0' RCP, square edge headwall, Ke= 0.500 Inlet / Outlet Invert= 96.00' / 95.90' S= 0.0100 '/' Cc= 0.900 n= 0.013, Flow Area= 1.77 sf	
#2	Device 1	100.50'	7.00" W x 3.00" H Vert. Orifice C= 0.600 Limited to weir flow at low heads	
#3	Device 1	102.60'	36.00" x 36.00" Horiz. Grate C= 0.600 in 36.00" x 36.00" Grate (100% open area) Limited to weir flow at low heads	

Primary OutFlow Max=0.83 cfs @ 4.26 hrs HW=102.03' (Free Discharge)

- ↑ 1=Outlet (Passes 0.83 cfs of 19.55 cfs potential flow)
- ↑ 2=Orifice (Orifice Controls 0.83 cfs @ 5.70 fps)
- ↑ 3=Grate (Controls 0.00 cfs)

Pond 3P: BMP-3 100-YR

Hydrograph

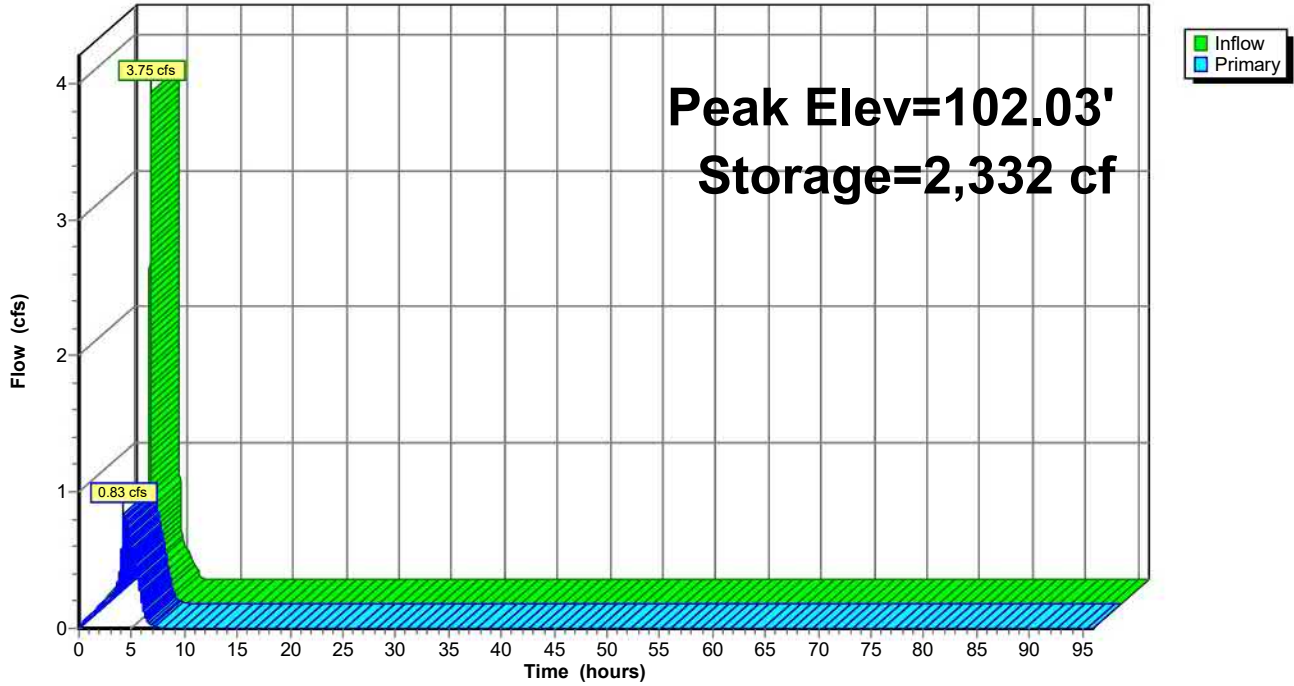

RATIONAL METHOD HYDROLOGY COMPUTER PROGRAM PACKAGE
Reference: SAN DIEGO COUNTY FLOOD CONTROL DISTRICT
2003,1985,1981 HYDROLOGY MANUAL
(c) Copyright 1982-2016 Advanced Engineering Software (aes)
Ver. 23.0 Release Date: 07/01/2016 License ID 1452

Analysis prepared by:

***** DESCRIPTION OF STUDY *****
* 3775 GUAJOME LAKE RD *
* PR-1 MITIGATED CONDITION *
* 100-YR *

FILE NAME: PR13775D.DAT
TIME/DATE OF STUDY: 14:40 08/05/2024

USER SPECIFIED HYDROLOGY AND HYDRAULIC MODEL INFORMATION:

2003 SAN DIEGO MANUAL CRITERIA

USER SPECIFIED STORM EVENT(YEAR) = 100.00
6-HOUR DURATION PRECIPITATION (INCHES) = 2.900
SPECIFIED MINIMUM PIPE SIZE(INCH) = 3.00
SPECIFIED PERCENT OF GRADIENTS(DECIMAL) TO USE FOR FRICTION SLOPE = 0.95
SAN DIEGO HYDROLOGY MANUAL "C"-VALUES USED FOR RATIONAL METHOD
NOTE: USE MODIFIED RATIONAL METHOD PROCEDURES FOR CONFLUENCE ANALYSIS

USER-DEFINED STREET-SECTIONS FOR COUPLED PIPEFLOW AND STREETFLOW MODEL
Table with columns: NO., WIDTH (FT), CROSSFALL (FT), SIDE / SIDE/ WAY, HEIGHT (FT), CURB GUTTER-GEOMETRIES: WIDTH (FT), LIP (FT), HIKE (FT), MANNING FACTOR (n)

GLOBAL STREET FLOW-DEPTH CONSTRAINTS:
1. Relative Flow-Depth = 0.50 FEET
as (Maximum Allowable Street Flow Depth) - (Top-of-Curb)
2. (Depth)*(Velocity) Constraint = 6.0 (FT*FT/S)
*SIZE PIPE WITH A FLOW CAPACITY GREATER THAN
OR EQUAL TO THE UPSTREAM TRIBUTARY PIPE.*

FLOW PROCESS FROM NODE 101.00 TO NODE 102.00 IS CODE = 21

>>>>RATIONAL METHOD INITIAL SUBAREA ANALYSIS<<<<
=====

*USER SPECIFIED(SUBAREA):
RESIDENTIAL (1. DU/AC OR LESS) RUNOFF COEFFICIENT = .6900
S.C.S. CURVE NUMBER (AMC II) = 0
INITIAL SUBAREA FLOW-LENGTH(FEET) = 50.00
UPSTREAM ELEVATION(FEET) = 171.70
DOWNSTREAM ELEVATION(FEET) = 171.20
ELEVATION DIFFERENCE(FEET) = 0.50
SUBAREA OVERLAND TIME OF FLOW(MIN.) = 5.218
100 YEAR RAINFALL INTENSITY(INCH/HOUR) = 7.433
SUBAREA RUNOFF(CFS) = 0.10
TOTAL AREA(ACRES) = 0.02 TOTAL RUNOFF(CFS) = 0.10

FLOW PROCESS FROM NODE 102.00 TO NODE 103.00 IS CODE = 31

>>>>COMPUTE PIPE-FLOW TRAVEL TIME THRU SUBAREA<<<<
>>>>USING COMPUTER-ESTIMATED PIPESIZE (NON-PRESSURE FLOW)<<<<

```

=====
ELEVATION DATA: UPSTREAM(FEET) = 171.20 DOWNSTREAM(FEET) = 169.80
FLOW LENGTH(FEET) = 64.00 MANNING'S N = 0.013
DEPTH OF FLOW IN 3.0 INCH PIPE IS 2.1 INCHES
PIPE-FLOW VELOCITY(FEET/SEC.) = 2.80
ESTIMATED PIPE DIAMETER(INCH) = 3.00 NUMBER OF PIPES = 1
PIPE-FLOW(CFS) = 0.10
PIPE TRAVEL TIME(MIN.) = 0.38 Tc(MIN.) = 5.60
LONGEST FLOWPATH FROM NODE 101.00 TO NODE 103.00 = 114.00 FEET.
*****
FLOW PROCESS FROM NODE 103.00 TO NODE 103.00 IS CODE = 81
-----
>>>>ADDITION OF SUBAREA TO MAINLINE PEAK FLOW<<<<
=====
100 YEAR RAINFALL INTENSITY(INCH/HOUR) = 7.102
*USER SPECIFIED(SUBAREA):
RESIDENTIAL (1. DU/AC OR LESS) RUNOFF COEFFICIENT = .6900
S.C.S. CURVE NUMBER (AMC II) = 0
AREA-AVERAGE RUNOFF COEFFICIENT = 0.6900
SUBAREA AREA(ACRES) = 0.04 SUBAREA RUNOFF(CFS) = 0.20
TOTAL AREA(ACRES) = 0.1 TOTAL RUNOFF(CFS) = 0.29
TC(MIN.) = 5.60
*****
FLOW PROCESS FROM NODE 103.00 TO NODE 104.00 IS CODE = 62
-----
>>>>COMPUTE STREET FLOW TRAVEL TIME THRU SUBAREA<<<<
>>>>(STREET TABLE SECTION # 1 USED)<<<<
=====
UPSTREAM ELEVATION(FEET) = 169.80 DOWNSTREAM ELEVATION(FEET) = 147.60
STREET LENGTH(FEET) = 281.00 CURB HEIGHT(INCHES) = 6.0
STREET HALFWIDTH(FEET) = 16.00

DISTANCE FROM CROWN TO CROSSFALL GRADEBREAK(FEET) = 11.00
INSIDE STREET CROSSFALL(DECIMAL) = 0.018
OUTSIDE STREET CROSSFALL(DECIMAL) = 0.018

SPECIFIED NUMBER OF HALFSTREETS CARRYING RUNOFF = 1
STREET PARKWAY CROSSFALL(DECIMAL) = 0.020
Manning's FRICTION FACTOR for Streetflow Section(curbs-to-curbs) = 0.0150
Manning's FRICTION FACTOR for Back-of-Walk Flow Section = 0.0200

**TRAVEL TIME COMPUTED USING ESTIMATED FLOW(CFS) = 1.75
STREETFLOW MODEL RESULTS USING ESTIMATED FLOW:
STREET FLOW DEPTH(FEET) = 0.23
HALFSTREET FLOOD WIDTH(FEET) = 5.39
AVERAGE FLOW VELOCITY(FEET/SEC.) = 4.61
PRODUCT OF DEPTH&VELOCITY(FT*FT/SEC.) = 1.04
STREET FLOW TRAVEL TIME(MIN.) = 1.02 Tc(MIN.) = 6.62
100 YEAR RAINFALL INTENSITY(INCH/HOUR) = 6.378
*USER SPECIFIED(SUBAREA):
RESIDENTIAL (1. DU/AC OR LESS) RUNOFF COEFFICIENT = .6900
S.C.S. CURVE NUMBER (AMC II) = 0
AREA-AVERAGE RUNOFF COEFFICIENT = 0.690
SUBAREA AREA(ACRES) = 0.66 SUBAREA RUNOFF(CFS) = 2.90
TOTAL AREA(ACRES) = 0.7 PEAK FLOW RATE(CFS) = 3.17

END OF SUBAREA STREET FLOW HYDRAULICS:
DEPTH(FEET) = 0.26 HALFSTREET FLOOD WIDTH(FEET) = 7.45
FLOW VELOCITY(FEET/SEC.) = 5.14 DEPTH*VELOCITY(FT*FT/SEC.) = 1.35
LONGEST FLOWPATH FROM NODE 101.00 TO NODE 104.00 = 395.00 FEET.
*****
FLOW PROCESS FROM NODE 104.00 TO NODE 105.00 IS CODE = 31
-----
>>>>COMPUTE PIPE-FLOW TRAVEL TIME THRU SUBAREA<<<<
>>>>USING COMPUTER-ESTIMATED PIPESIZE (NON-PRESSURE FLOW)<<<<
=====
ELEVATION DATA: UPSTREAM(FEET) = 147.60 DOWNSTREAM(FEET) = 143.10
FLOW LENGTH(FEET) = 213.00 MANNING'S N = 0.013

```

DEPTH OF FLOW IN 12.0 INCH PIPE IS 6.9 INCHES
PIPE-FLOW VELOCITY (FEET/SEC.) = 6.79
ESTIMATED PIPE DIAMETER (INCH) = 12.00 NUMBER OF PIPES = 1
PIPE-FLOW (CFS) = 3.17
PIPE TRAVEL TIME (MIN.) = 0.52 Tc (MIN.) = 7.14
LONGEST FLOWPATH FROM NODE 101.00 TO NODE 105.00 = 608.00 FEET.

FLOW PROCESS FROM NODE 105.00 TO NODE 105.00 IS CODE = 81

>>>>ADDITION OF SUBAREA TO MAINLINE PEAK FLOW<<<<<

=====

100 YEAR RAINFALL INTENSITY (INCH/HOUR) = 6.072
*USER SPECIFIED (SUBAREA):
RESIDENTIAL (7.3 DU/AC OR LESS) RUNOFF COEFFICIENT = .6900
S.C.S. CURVE NUMBER (AMC II) = 0
AREA-AVERAGE RUNOFF COEFFICIENT = 0.6900
SUBAREA AREA (ACRES) = 0.91 SUBAREA RUNOFF (CFS) = 3.81
TOTAL AREA (ACRES) = 1.6 TOTAL RUNOFF (CFS) = 6.83
Tc (MIN.) = 7.14

FLOW PROCESS FROM NODE 105.00 TO NODE 106.00 IS CODE = 31

>>>>COMPUTE PIPE-FLOW TRAVEL TIME THRU SUBAREA<<<<<
>>>>USING COMPUTER-ESTIMATED PIPESIZE (NON-PRESSURE FLOW)<<<<<

=====

ELEVATION DATA: UPSTREAM (FEET) = 143.10 DOWNSTREAM (FEET) = 139.50
FLOW LENGTH (FEET) = 214.00 MANNING'S N = 0.013
DEPTH OF FLOW IN 15.0 INCH PIPE IS 10.5 INCHES
PIPE-FLOW VELOCITY (FEET/SEC.) = 7.45
ESTIMATED PIPE DIAMETER (INCH) = 15.00 NUMBER OF PIPES = 1
PIPE-FLOW (CFS) = 6.83
PIPE TRAVEL TIME (MIN.) = 0.48 Tc (MIN.) = 7.62
LONGEST FLOWPATH FROM NODE 101.00 TO NODE 106.00 = 822.00 FEET.

FLOW PROCESS FROM NODE 107.00 TO NODE 107.00 IS CODE = 1

>>>>DESIGNATE INDEPENDENT STREAM FOR CONFLUENCE<<<<<

=====

TOTAL NUMBER OF STREAMS = 2
CONFLUENCE VALUES USED FOR INDEPENDENT STREAM 1 ARE:
TIME OF CONCENTRATION (MIN.) = 7.62
RAINFALL INTENSITY (INCH/HR) = 5.82
TOTAL STREAM AREA (ACRES) = 1.63
PEAK FLOW RATE (CFS) AT CONFLUENCE = 6.83

FLOW PROCESS FROM NODE 110.00 TO NODE 111.00 IS CODE = 21

>>>>RATIONAL METHOD INITIAL SUBAREA ANALYSIS<<<<<

=====

*USER SPECIFIED (SUBAREA):
RESIDENTIAL (7.3 DU/AC OR LESS) RUNOFF COEFFICIENT = .6900
S.C.S. CURVE NUMBER (AMC II) = 0
INITIAL SUBAREA FLOW-LENGTH (FEET) = 80.00
UPSTREAM ELEVATION (FEET) = 177.00
DOWNSTREAM ELEVATION (FEET) = 176.20
ELEVATION DIFFERENCE (FEET) = 0.80
SUBAREA OVERLAND TIME OF FLOW (MIN.) = 5.950
WARNING: INITIAL SUBAREA FLOW PATH LENGTH IS GREATER THAN
THE MAXIMUM OVERLAND FLOW LENGTH = 65.00
(Reference: Table 3-1B of Hydrology Manual)
THE MAXIMUM OVERLAND FLOW LENGTH IS USED IN Tc CALCULATION!
100 YEAR RAINFALL INTENSITY (INCH/HOUR) = 6.830
SUBAREA RUNOFF (CFS) = 0.28
TOTAL AREA (ACRES) = 0.06 TOTAL RUNOFF (CFS) = 0.28

FLOW PROCESS FROM NODE 111.00 TO NODE 112.00 IS CODE = 31

```

-----
>>>>COMPUTE PIPE-FLOW TRAVEL TIME THRU SUBAREA<<<<
>>>>USING COMPUTER-ESTIMATED PIPESIZE (NON-PRESSURE FLOW)<<<<
=====
ELEVATION DATA: UPSTREAM(FEET) = 176.20 DOWNSTREAM(FEET) = 174.00
FLOW LENGTH(FEET) = 72.00 MANNING'S N = 0.013
DEPTH OF FLOW IN 6.0 INCH PIPE IS 2.2 INCHES
PIPE-FLOW VELOCITY(FEET/SEC.) = 4.27
ESTIMATED PIPE DIAMETER(INCH) = 6.00 NUMBER OF PIPES = 1
PIPE-FLOW(CFS) = 0.28
PIPE TRAVEL TIME(MIN.) = 0.28 Tc(MIN.) = 6.23
LONGEST FLOWPATH FROM NODE 110.00 TO NODE 112.00 = 152.00 FEET.

*****
FLOW PROCESS FROM NODE 112.00 TO NODE 112.00 IS CODE = 81
-----
>>>>ADDITION OF SUBAREA TO MAINLINE PEAK FLOW<<<<
=====
100 YEAR RAINFALL INTENSITY(INCH/HOUR) = 6.630
*USER SPECIFIED(SUBAREA):
RESIDENTIAL (7.3 DU/AC OR LESS) RUNOFF COEFFICIENT = .6900
S.C.S. CURVE NUMBER (AMC II) = 0
AREA-AVERAGE RUNOFF COEFFICIENT = 0.6900
SUBAREA AREA(ACRES) = 0.07 SUBAREA RUNOFF(CFS) = 0.32
TOTAL AREA(ACRES) = 0.1 TOTAL RUNOFF(CFS) = 0.59
TC(MIN.) = 6.23

*****
FLOW PROCESS FROM NODE 112.00 TO NODE 113.00 IS CODE = 62
-----
>>>>COMPUTE STREET FLOW TRAVEL TIME THRU SUBAREA<<<<
>>>>(STREET TABLE SECTION # 1 USED)<<<<
=====
UPSTREAM ELEVATION(FEET) = 174.00 DOWNSTREAM ELEVATION(FEET) = 162.10
STREET LENGTH(FEET) = 163.00 CURB HEIGHT(INCHES) = 6.0
STREET HALFWIDTH(FEET) = 16.00

DISTANCE FROM CROWN TO CROSSFALL GRADEBREAK(FEET) = 11.00
INSIDE STREET CROSSFALL(DECIMAL) = 0.018
OUTSIDE STREET CROSSFALL(DECIMAL) = 0.018

SPECIFIED NUMBER OF HALFSTREETS CARRYING RUNOFF = 2
STREET PARKWAY CROSSFALL(DECIMAL) = 0.020
Manning's FRICTION FACTOR for Streetflow Section(curbs-to-curbs) = 0.0150
Manning's FRICTION FACTOR for Back-of-Walk Flow Section = 0.0200

**TRAVEL TIME COMPUTED USING ESTIMATED FLOW(CFS) = 2.29
STREETFLOW MODEL RESULTS USING ESTIMATED FLOW:
STREET FLOW DEPTH(FEET) = 0.20
HALFSTREET FLOOD WIDTH(FEET) = 4.07
AVERAGE FLOW VELOCITY(FEET/SEC.) = 4.27
PRODUCT OF DEPTH&VELOCITY(FT*FT/SEC.) = 0.86
STREET FLOW TRAVEL TIME(MIN.) = 0.64 Tc(MIN.) = 6.87
100 YEAR RAINFALL INTENSITY(INCH/HOUR) = 6.226
*USER SPECIFIED(SUBAREA):
RESIDENTIAL (7.3 DU/AC OR LESS) RUNOFF COEFFICIENT = .6900
S.C.S. CURVE NUMBER (AMC II) = 0
AREA-AVERAGE RUNOFF COEFFICIENT = 0.690
SUBAREA AREA(ACRES) = 0.79 SUBAREA RUNOFF(CFS) = 3.39
TOTAL AREA(ACRES) = 0.9 PEAK FLOW RATE(CFS) = 3.95

END OF SUBAREA STREET FLOW HYDRAULICS:
DEPTH(FEET) = 0.23 HALFSTREET FLOOD WIDTH(FEET) = 5.90
FLOW VELOCITY(FEET/SEC.) = 4.58 DEPTH*VELOCITY(FT*FT/SEC.) = 1.08
LONGEST FLOWPATH FROM NODE 110.00 TO NODE 113.00 = 315.00 FEET.

*****
FLOW PROCESS FROM NODE 113.00 TO NODE 114.00 IS CODE = 31
-----
>>>>COMPUTE PIPE-FLOW TRAVEL TIME THRU SUBAREA<<<<
>>>>USING COMPUTER-ESTIMATED PIPESIZE (NON-PRESSURE FLOW)<<<<

```

```

=====
ELEVATION DATA: UPSTREAM(FEET) = 162.10 DOWNSTREAM(FEET) = 139.60
FLOW LENGTH(FEET) = 226.00 MANNING'S N = 0.013
DEPTH OF FLOW IN 9.0 INCH PIPE IS 6.0 INCHES
PIPE-FLOW VELOCITY(FEET/SEC.) = 12.72
ESTIMATED PIPE DIAMETER(INCH) = 9.00 NUMBER OF PIPES = 1
PIPE-FLOW(CFS) = 3.95
PIPE TRAVEL TIME(MIN.) = 0.30 Tc(MIN.) = 7.16
LONGEST FLOWPATH FROM NODE 110.00 TO NODE 114.00 = 541.00 FEET.
*****
FLOW PROCESS FROM NODE 114.00 TO NODE 114.00 IS CODE = 81
-----
>>>>ADDITION OF SUBAREA TO MAINLINE PEAK FLOW<<<<
=====
100 YEAR RAINFALL INTENSITY(INCH/HOUR) = 6.059
*USER SPECIFIED(SUBAREA):
RESIDENTIAL (7.3 DU/AC OR LESS) RUNOFF COEFFICIENT = .6900
S.C.S. CURVE NUMBER (AMC II) = 0
AREA-AVERAGE RUNOFF COEFFICIENT = 0.6900
SUBAREA AREA(ACRES) = 1.85 SUBAREA RUNOFF(CFS) = 7.73
TOTAL AREA(ACRES) = 2.8 TOTAL RUNOFF(CFS) = 11.58
TC(MIN.) = 7.16
*****
FLOW PROCESS FROM NODE 114.00 TO NODE 115.00 IS CODE = 31
-----
>>>>COMPUTE PIPE-FLOW TRAVEL TIME THRU SUBAREA<<<<
>>>>USING COMPUTER-ESTIMATED PIPESIZE (NON-PRESSURE FLOW)<<<<
=====
ELEVATION DATA: UPSTREAM(FEET) = 139.60 DOWNSTREAM(FEET) = 139.50
FLOW LENGTH(FEET) = 20.00 MANNING'S N = 0.013
DEPTH OF FLOW IN 24.0 INCH PIPE IS 15.4 INCHES
PIPE-FLOW VELOCITY(FEET/SEC.) = 5.43
ESTIMATED PIPE DIAMETER(INCH) = 24.00 NUMBER OF PIPES = 1
PIPE-FLOW(CFS) = 11.58
PIPE TRAVEL TIME(MIN.) = 0.06 Tc(MIN.) = 7.23
LONGEST FLOWPATH FROM NODE 110.00 TO NODE 115.00 = 561.00 FEET.
*****
FLOW PROCESS FROM NODE 115.00 TO NODE 115.00 IS CODE = 1
-----
>>>>DESIGNATE INDEPENDENT STREAM FOR CONFLUENCE<<<<
>>>>AND COMPUTE VARIOUS CONFLUENCED STREAM VALUES<<<<
=====
TOTAL NUMBER OF STREAMS = 2
CONFLUENCE VALUES USED FOR INDEPENDENT STREAM 2 ARE:
TIME OF CONCENTRATION(MIN.) = 7.23
RAINFALL INTENSITY(INCH/HR) = 6.03
TOTAL STREAM AREA(ACRES) = 2.77
PEAK FLOW RATE(CFS) AT CONFLUENCE = 11.58

** CONFLUENCE DATA **
STREAM RUNOFF Tc INTENSITY AREA
NUMBER (CFS) (MIN.) (INCH/HOUR) (ACRE)
1 6.83 7.62 5.823 1.63
2 11.58 7.23 6.026 2.77

RAINFALL INTENSITY AND TIME OF CONCENTRATION RATIO
CONFLUENCE FORMULA USED FOR 2 STREAMS.

** PEAK FLOW RATE TABLE **
STREAM RUNOFF Tc INTENSITY
NUMBER (CFS) (MIN.) (INCH/HOUR)
1 18.06 7.23 6.026
2 18.02 7.62 5.823

COMPUTED CONFLUENCE ESTIMATES ARE AS FOLLOWS:
PEAK FLOW RATE(CFS) = 18.06 Tc(MIN.) = 7.23
TOTAL AREA(ACRES) = 4.4
LONGEST FLOWPATH FROM NODE 101.00 TO NODE 115.00 = 822.00 FEET.

```

```

*****
FLOW PROCESS FROM NODE    116.00 TO NODE    116.00 IS CODE = 81
-----
>>>>ADDITION OF SUBAREA TO MAINLINE PEAK FLOW<<<<
=====
    100 YEAR RAINFALL INTENSITY(INCH/HOUR) = 6.026
*USER SPECIFIED(SUBAREA):
RESIDENTIAL (7.3 DU/AC OR LESS) RUNOFF COEFFICIENT = .6900
S.C.S. CURVE NUMBER (AMC II) = 0
AREA-AVERAGE RUNOFF COEFFICIENT = 0.6900
SUBAREA AREA (ACRES) = 0.30 SUBAREA RUNOFF (CFS) = 1.25
TOTAL AREA (ACRES) = 4.7 TOTAL RUNOFF (CFS) = 19.54
TC (MIN.) = 7.23

*****
FLOW PROCESS FROM NODE    116.00 TO NODE    116.00 IS CODE = 7
-----
>>>>USER SPECIFIED HYDROLOGY INFORMATION AT NODE<<<<
=====
USER-SPECIFIED VALUES ARE AS FOLLOWS:
TC (MIN) = 13.13 RAIN INTENSITY(INCH/HOUR) = 4.10
TOTAL AREA (ACRES) = 4.70 TOTAL RUNOFF (CFS) = 5.85

*****
FLOW PROCESS FROM NODE    116.00 TO NODE    117.00 IS CODE = 31
-----
>>>>COMPUTE PIPE-FLOW TRAVEL TIME THRU SUBAREA<<<<
>>>>USING COMPUTER-ESTIMATED PIPESIZE (NON-PRESSURE FLOW)<<<<
=====
ELEVATION DATA: UPSTREAM(FEET) = 135.00 DOWNSTREAM(FEET) = 133.00
FLOW LENGTH(FEET) = 96.00 MANNING'S N = 0.013
DEPTH OF FLOW IN 15.0 INCH PIPE IS 8.8 INCHES
PIPE-FLOW VELOCITY(FEET/SEC.) = 7.86
ESTIMATED PIPE DIAMETER(INCH) = 15.00 NUMBER OF PIPES = 1
PIPE-FLOW (CFS) = 5.85
PIPE TRAVEL TIME(MIN.) = 0.20 Tc(MIN.) = 13.33
LONGEST FLOWPATH FROM NODE 101.00 TO NODE 117.00 = 918.00 FEET.

*****
FLOW PROCESS FROM NODE    117.00 TO NODE    117.00 IS CODE = 1
-----
>>>>DESIGNATE INDEPENDENT STREAM FOR CONFLUENCE<<<<
=====
TOTAL NUMBER OF STREAMS = 2
CONFLUENCE VALUES USED FOR INDEPENDENT STREAM 1 ARE:
TIME OF CONCENTRATION(MIN.) = 13.33
RAINFALL INTENSITY(INCH/HR) = 4.06
TOTAL STREAM AREA (ACRES) = 4.70
PEAK FLOW RATE (CFS) AT CONFLUENCE = 5.85

*****
FLOW PROCESS FROM NODE    117.00 TO NODE    117.00 IS CODE = 7
-----
>>>>USER SPECIFIED HYDROLOGY INFORMATION AT NODE<<<<
=====
USER-SPECIFIED VALUES ARE AS FOLLOWS:
TC (MIN) = 7.38 RAIN INTENSITY(INCH/HOUR) = 5.94
TOTAL AREA (ACRES) = 0.58 TOTAL RUNOFF (CFS) = 2.65

*****
FLOW PROCESS FROM NODE    117.00 TO NODE    117.00 IS CODE = 1
-----
>>>>DESIGNATE INDEPENDENT STREAM FOR CONFLUENCE<<<<
>>>>AND COMPUTE VARIOUS CONFLUENCED STREAM VALUES<<<<
=====
TOTAL NUMBER OF STREAMS = 2
CONFLUENCE VALUES USED FOR INDEPENDENT STREAM 2 ARE:
TIME OF CONCENTRATION(MIN.) = 7.38
RAINFALL INTENSITY(INCH/HR) = 5.94
TOTAL STREAM AREA (ACRES) = 0.58

```

PEAK FLOW RATE (CFS) AT CONFLUENCE = 2.65

** CONFLUENCE DATA **

STREAM NUMBER	RUNOFF (CFS)	Tc (MIN.)	INTENSITY (INCH/HOUR)	AREA (ACRE)
1	5.85	13.33	4.059	4.70
2	2.65	7.38	5.944	0.58

RAINFALL INTENSITY AND TIME OF CONCENTRATION RATIO
CONFLUENCE FORMULA USED FOR 2 STREAMS.

** PEAK FLOW RATE TABLE **

STREAM NUMBER	RUNOFF (CFS)	Tc (MIN.)	INTENSITY (INCH/HOUR)
1	5.89	7.38	5.944
2	7.66	13.33	4.059

COMPUTED CONFLUENCE ESTIMATES ARE AS FOLLOWS:

PEAK FLOW RATE (CFS) = 7.66 Tc (MIN.) = 13.33
TOTAL AREA (ACRES) = 5.3
LONGEST FLOWPATH FROM NODE 101.00 TO NODE 117.00 = 918.00 FEET.

=====
END OF STUDY SUMMARY:

TOTAL AREA (ACRES) = 5.3 TC (MIN.) = 13.33
PEAK FLOW RATE (CFS) = 7.66
=====

=====
END OF RATIONAL METHOD ANALYSIS

RATIONAL METHOD HYDROLOGY COMPUTER PROGRAM PACKAGE
Reference: SAN DIEGO COUNTY FLOOD CONTROL DISTRICT
2003,1985,1981 HYDROLOGY MANUAL
(c) Copyright 1982-2016 Advanced Engineering Software (aes)
Ver. 23.0 Release Date: 07/01/2016 License ID 1452

Analysis prepared by:

***** DESCRIPTION OF STUDY *****
* 3775 GUAJOME LAKE RD *
* PR-2 MITIGATED CONDITION *
* 100-YR *

FILE NAME: PR23775D.DAT
TIME/DATE OF STUDY: 09:19 08/06/2024

USER SPECIFIED HYDROLOGY AND HYDRAULIC MODEL INFORMATION:

2003 SAN DIEGO MANUAL CRITERIA

USER SPECIFIED STORM EVENT(YEAR) = 100.00
6-HOUR DURATION PRECIPITATION (INCHES) = 2.900
SPECIFIED MINIMUM PIPE SIZE(INCH) = 3.00
SPECIFIED PERCENT OF GRADIENTS(DECIMAL) TO USE FOR FRICTION SLOPE = 0.95
SAN DIEGO HYDROLOGY MANUAL "C"-VALUES USED FOR RATIONAL METHOD

NOTE: USE MODIFIED RATIONAL METHOD PROCEDURES FOR CONFLUENCE ANALYSIS

USER-DEFINED STREET-SECTIONS FOR COUPLED PIPEFLOW AND STREETFLOW MODEL

Table with columns: NO., WIDTH (FT), CROSSFALL (FT), SIDE / SIDE/ WAY, HEIGHT (FT), CURB GUTTER-GEOMETRIES: MANNING, WIDTH LIP HIKE FACTOR (n). Row 1: 1, 16.0, 11.0, 0.018/0.018/0.020, 0.50, 1.50 0.0312 0.125 0.0150

GLOBAL STREET FLOW-DEPTH CONSTRAINTS:

- 1. Relative Flow-Depth = 0.50 FEET
as (Maximum Allowable Street Flow Depth) - (Top-of-Curb)
2. (Depth)*(Velocity) Constraint = 6.0 (FT*FT/S)

*SIZE PIPE WITH A FLOW CAPACITY GREATER THAN
OR EQUAL TO THE UPSTREAM TRIBUTARY PIPE.*

FLOW PROCESS FROM NODE 201.00 TO NODE 202.00 IS CODE = 21

>>>>RATIONAL METHOD INITIAL SUBAREA ANALYSIS<<<<

*USER SPECIFIED(SUBAREA):
RESIDENTIAL (7.3 DU/AC OR LESS) RUNOFF COEFFICIENT = .7300
S.C.S. CURVE NUMBER (AMC II) = 0
INITIAL SUBAREA FLOW-LENGTH(FEET) = 50.00
UPSTREAM ELEVATION(FEET) = 177.60
DOWNSTREAM ELEVATION(FEET) = 177.10
ELEVATION DIFFERENCE(FEET) = 0.50
SUBAREA OVERLAND TIME OF FLOW(MIN.) = 4.709
100 YEAR RAINFALL INTENSITY(INCH/HOUR) = 7.641
NOTE: RAINFALL INTENSITY IS BASED ON Tc = 5-MINUTE.
SUBAREA RUNOFF(CFS) = 0.11
TOTAL AREA(ACRES) = 0.02 TOTAL RUNOFF(CFS) = 0.11

FLOW PROCESS FROM NODE 202.00 TO NODE 203.00 IS CODE = 31

>>>>COMPUTE PIPE-FLOW TRAVEL TIME THRU SUBAREA<<<<

```

>>>>USING COMPUTER-ESTIMATED PIPESIZE (NON-PRESSURE FLOW)<<<<
=====
ELEVATION DATA: UPSTREAM(FEET) = 177.10 DOWNSTREAM(FEET) = 176.00
FLOW LENGTH(FEET) = 45.00 MANNING'S N = 0.013
DEPTH OF FLOW IN 3.0 INCH PIPE IS 2.1 INCHES
PIPE-FLOW VELOCITY(FEET/SEC.) = 3.04
ESTIMATED PIPE DIAMETER(INCH) = 3.00 NUMBER OF PIPES = 1
PIPE-FLOW(CFS) = 0.11
PIPE TRAVEL TIME(MIN.) = 0.25 Tc(MIN.) = 4.96
LONGEST FLOWPATH FROM NODE 201.00 TO NODE 203.00 = 95.00 FEET.

*****
FLOW PROCESS FROM NODE 203.00 TO NODE 203.00 IS CODE = 81
-----
>>>>ADDITION OF SUBAREA TO MAINLINE PEAK FLOW<<<<
=====
100 YEAR RAINFALL INTENSITY(INCH/HOUR) = 7.641
NOTE: RAINFALL INTENSITY IS BASED ON Tc = 5-MINUTE.
*USER SPECIFIED(SUBAREA):
RESIDENTIAL (7.3 DU/AC OR LESS) RUNOFF COEFFICIENT = .7300
S.C.S. CURVE NUMBER (AMC II) = 0
AREA-AVERAGE RUNOFF COEFFICIENT = 0.7300
SUBAREA AREA(ACRES) = 0.03 SUBAREA RUNOFF(CFS) = 0.17
TOTAL AREA(ACRES) = 0.0 TOTAL RUNOFF(CFS) = 0.28
TC(MIN.) = 4.96

*****
FLOW PROCESS FROM NODE 203.00 TO NODE 204.00 IS CODE = 62
-----
>>>>COMPUTE STREET FLOW TRAVEL TIME THRU SUBAREA<<<<
>>>>(STREET TABLE SECTION # 1 USED)<<<<
=====
UPSTREAM ELEVATION(FEET) = 176.00 DOWNSTREAM ELEVATION(FEET) = 172.20
STREET LENGTH(FEET) = 329.00 CURB HEIGHT(INCHES) = 6.0
STREET HALFWIDTH(FEET) = 16.00

DISTANCE FROM CROWN TO CROSSFALL GRADEBREAK(FEET) = 11.00
INSIDE STREET CROSSFALL(DECIMAL) = 0.018
OUTSIDE STREET CROSSFALL(DECIMAL) = 0.018

SPECIFIED NUMBER OF HALFSTREETS CARRYING RUNOFF = 1
STREET PARKWAY CROSSFALL(DECIMAL) = 0.020
Manning's FRICTION FACTOR for Streetflow Section(curbs-to-curbs) = 0.0150
Manning's FRICTION FACTOR for Back-of-Walk Flow Section = 0.0200

**TRAVEL TIME COMPUTED USING ESTIMATED FLOW(CFS) = 3.63
STREETFLOW MODEL RESULTS USING ESTIMATED FLOW:
STREET FLOW DEPTH(FEET) = 0.35
HALFSTREET FLOOD WIDTH(FEET) = 12.18
AVERAGE FLOW VELOCITY(FEET/SEC.) = 2.52
PRODUCT OF DEPTH&VELOCITY(FT*FT/SEC.) = 0.87
STREET FLOW TRAVEL TIME(MIN.) = 2.18 Tc(MIN.) = 7.14
100 YEAR RAINFALL INTENSITY(INCH/HOUR) = 6.074
*USER SPECIFIED(SUBAREA):
RESIDENTIAL (7.3 DU/AC OR LESS) RUNOFF COEFFICIENT = .7300
S.C.S. CURVE NUMBER (AMC II) = 0
AREA-AVERAGE RUNOFF COEFFICIENT = 0.7300
SUBAREA AREA(ACRES) = 1.50 SUBAREA RUNOFF(CFS) = 6.65
TOTAL AREA(ACRES) = 1.5 PEAK FLOW RATE(CFS) = 6.87

END OF SUBAREA STREET FLOW HYDRAULICS:
DEPTH(FEET) = 0.41 HALFSTREET FLOOD WIDTH(FEET) = 15.79
FLOW VELOCITY(FEET/SEC.) = 2.93 DEPTH*VELOCITY(FT*FT/SEC.) = 1.21
LONGEST FLOWPATH FROM NODE 201.00 TO NODE 204.00 = 424.00 FEET.

*****
FLOW PROCESS FROM NODE 204.00 TO NODE 205.00 IS CODE = 31
-----
>>>>COMPUTE PIPE-FLOW TRAVEL TIME THRU SUBAREA<<<<
>>>>USING COMPUTER-ESTIMATED PIPESIZE (NON-PRESSURE FLOW)<<<<
=====

```

ELEVATION DATA: UPSTREAM(FEET) = 172.20 DOWNSTREAM(FEET) = 154.20
FLOW LENGTH(FEET) = 218.00 MANNING'S N = 0.013
DEPTH OF FLOW IN 12.0 INCH PIPE IS 7.3 INCHES
PIPE-FLOW VELOCITY(FEET/SEC.) = 13.70
ESTIMATED PIPE DIAMETER(INCH) = 12.00 NUMBER OF PIPES = 1
PIPE-FLOW(CFS) = 6.87
PIPE TRAVEL TIME(MIN.) = 0.27 Tc(MIN.) = 7.40
LONGEST FLOWPATH FROM NODE 201.00 TO NODE 205.00 = 642.00 FEET.

FLOW PROCESS FROM NODE 205.00 TO NODE 205.00 IS CODE = 81

>>>>ADDITION OF SUBAREA TO MAINLINE PEAK FLOW<<<<<

=====

100 YEAR RAINFALL INTENSITY(INCH/HOUR) = 5.933
*USER SPECIFIED(SUBAREA):
RESIDENTIAL (7.3 DU/AC OR LESS) RUNOFF COEFFICIENT = .7300
S.C.S. CURVE NUMBER (AMC II) = 0
AREA-AVERAGE RUNOFF COEFFICIENT = 0.7300
SUBAREA AREA (ACRES) = 1.16 SUBAREA RUNOFF(CFS) = 5.02
TOTAL AREA(ACRES) = 2.7 TOTAL RUNOFF(CFS) = 11.74
TC(MIN.) = 7.40

FLOW PROCESS FROM NODE 205.00 TO NODE 206.00 IS CODE = 31

>>>>COMPUTE PIPE-FLOW TRAVEL TIME THRU SUBAREA<<<<<
>>>>USING COMPUTER-ESTIMATED PIPESIZE (NON-PRESSURE FLOW)<<<<<

=====

ELEVATION DATA: UPSTREAM(FEET) = 154.20 DOWNSTREAM(FEET) = 154.00
FLOW LENGTH(FEET) = 20.00 MANNING'S N = 0.013
DEPTH OF FLOW IN 21.0 INCH PIPE IS 13.7 INCHES
PIPE-FLOW VELOCITY(FEET/SEC.) = 7.07
ESTIMATED PIPE DIAMETER(INCH) = 21.00 NUMBER OF PIPES = 1
PIPE-FLOW(CFS) = 11.74
PIPE TRAVEL TIME(MIN.) = 0.05 Tc(MIN.) = 7.45
LONGEST FLOWPATH FROM NODE 201.00 TO NODE 206.00 = 662.00 FEET.

FLOW PROCESS FROM NODE 206.00 TO NODE 206.00 IS CODE = 81

>>>>ADDITION OF SUBAREA TO MAINLINE PEAK FLOW<<<<<

=====

100 YEAR RAINFALL INTENSITY(INCH/HOUR) = 5.909
*USER SPECIFIED(SUBAREA):
RESIDENTIAL (7.3 DU/AC OR LESS) RUNOFF COEFFICIENT = .7300
S.C.S. CURVE NUMBER (AMC II) = 0
AREA-AVERAGE RUNOFF COEFFICIENT = 0.7300
SUBAREA AREA (ACRES) = 0.14 SUBAREA RUNOFF(CFS) = 0.60
TOTAL AREA(ACRES) = 2.9 TOTAL RUNOFF(CFS) = 12.29
TC(MIN.) = 7.45

FLOW PROCESS FROM NODE 206.00 TO NODE 206.00 IS CODE = 7

>>>>USER SPECIFIED HYDROLOGY INFORMATION AT NODE<<<<<

=====

USER-SPECIFIED VALUES ARE AS FOLLOWS:
TC(MIN) = 12.25 RAIN INTENSITY(INCH/HOUR) = 4.29
TOTAL AREA(ACRES) = 2.85 TOTAL RUNOFF(CFS) = 5.21

FLOW PROCESS FROM NODE 207.00 TO NODE 208.00 IS CODE = 31

>>>>COMPUTE PIPE-FLOW TRAVEL TIME THRU SUBAREA<<<<<
>>>>USING COMPUTER-ESTIMATED PIPESIZE (NON-PRESSURE FLOW)<<<<<

=====

ELEVATION DATA: UPSTREAM(FEET) = 150.10 DOWNSTREAM(FEET) = 134.40
FLOW LENGTH(FEET) = 97.00 MANNING'S N = 0.013
DEPTH OF FLOW IN 9.0 INCH PIPE IS 6.1 INCHES
PIPE-FLOW VELOCITY(FEET/SEC.) = 16.32

ESTIMATED PIPE DIAMETER(INCH) = 9.00 NUMBER OF PIPES = 1
PIPE-FLOW(CFS) = 5.21
PIPE TRAVEL TIME(MIN.) = 0.10 Tc(MIN.) = 12.35
LONGEST FLOWPATH FROM NODE 201.00 TO NODE 208.00 = 759.00 FEET.

FLOW PROCESS FROM NODE 208.00 TO NODE 208.00 IS CODE = 1

>>>>DESIGNATE INDEPENDENT STREAM FOR CONFLUENCE<<<<<

=====

TOTAL NUMBER OF STREAMS = 2
CONFLUENCE VALUES USED FOR INDEPENDENT STREAM 1 ARE:
TIME OF CONCENTRATION(MIN.) = 12.35
RAINFALL INTENSITY(INCH/HR) = 4.26
TOTAL STREAM AREA(ACRES) = 2.85
PEAK FLOW RATE(CFS) AT CONFLUENCE = 5.21

FLOW PROCESS FROM NODE 301.00 TO NODE 302.00 IS CODE = 21

>>>>RATIONAL METHOD INITIAL SUBAREA ANALYSIS<<<<<

=====

*USER SPECIFIED(SUBAREA):
RESIDENTIAL (7.3 DU/AC OR LESS) RUNOFF COEFFICIENT = .6200
S.C.S. CURVE NUMBER (AMC II) = 0
INITIAL SUBAREA FLOW-LENGTH(FEET) = 50.00
UPSTREAM ELEVATION(FEET) = 179.00
DOWNSTREAM ELEVATION(FEET) = 178.50
ELEVATION DIFFERENCE(FEET) = 0.50
SUBAREA OVERLAND TIME OF FLOW(MIN.) = 6.109
100 YEAR RAINFALL INTENSITY(INCH/HOUR) = 6.714
SUBAREA RUNOFF(CFS) = 0.12
TOTAL AREA(ACRES) = 0.03 TOTAL RUNOFF(CFS) = 0.12

FLOW PROCESS FROM NODE 302.00 TO NODE 303.00 IS CODE = 31

>>>>COMPUTE PIPE-FLOW TRAVEL TIME THRU SUBAREA<<<<<
>>>>USING COMPUTER-ESTIMATED PIPESIZE (NON-PRESSURE FLOW)<<<<<

=====

ELEVATION DATA: UPSTREAM(FEET) = 178.50 DOWNSTREAM(FEET) = 177.30
FLOW LENGTH(FEET) = 48.00 MANNING'S N = 0.013
DEPTH OF FLOW IN 3.0 INCH PIPE IS 2.3 INCHES
PIPE-FLOW VELOCITY(FEET/SEC.) = 3.11
ESTIMATED PIPE DIAMETER(INCH) = 3.00 NUMBER OF PIPES = 1
PIPE-FLOW(CFS) = 0.12
PIPE TRAVEL TIME(MIN.) = 0.26 Tc(MIN.) = 6.37
LONGEST FLOWPATH FROM NODE 301.00 TO NODE 303.00 = 98.00 FEET.

FLOW PROCESS FROM NODE 303.00 TO NODE 303.00 IS CODE = 81

>>>>ADDITION OF SUBAREA TO MAINLINE PEAK FLOW<<<<<

=====

100 YEAR RAINFALL INTENSITY(INCH/HOUR) = 6.538
*USER SPECIFIED(SUBAREA):
RESIDENTIAL (7.3 DU/AC OR LESS) RUNOFF COEFFICIENT = .6200
S.C.S. CURVE NUMBER (AMC II) = 0
AREA-AVERAGE RUNOFF COEFFICIENT = 0.6200
SUBAREA AREA(ACRES) = 0.03 SUBAREA RUNOFF(CFS) = 0.12
TOTAL AREA(ACRES) = 0.1 TOTAL RUNOFF(CFS) = 0.24
TC(MIN.) = 6.37

FLOW PROCESS FROM NODE 303.00 TO NODE 304.00 IS CODE = 62

>>>>COMPUTE STREET FLOW TRAVEL TIME THRU SUBAREA<<<<<
>>>>(STREET TABLE SECTION # 1 USED)<<<<<

=====

UPSTREAM ELEVATION(FEET) = 177.30 DOWNSTREAM ELEVATION(FEET) = 175.60
STREET LENGTH(FEET) = 128.00 CURB HEIGHT(INCHES) = 6.0

STREET HALFWIDTH (FEET) = 16.00

DISTANCE FROM CROWN TO CROSSFALL GRADEBREAK (FEET) = 11.00
INSIDE STREET CROSSFALL (DECIMAL) = 0.018
OUTSIDE STREET CROSSFALL (DECIMAL) = 0.018

SPECIFIED NUMBER OF HALFSTREETS CARRYING RUNOFF = 1
STREET PARKWAY CROSSFALL (DECIMAL) = 0.020
Manning's FRICTION FACTOR for Streetflow Section (curb-to-curb) = 0.0150
Manning's FRICTION FACTOR for Back-of-Walk Flow Section = 0.0200

**TRAVEL TIME COMPUTED USING ESTIMATED FLOW (CFS) = 1.20
STREETFLOW MODEL RESULTS USING ESTIMATED FLOW:
STREET FLOW DEPTH (FEET) = 0.26
HALFSTREET FLOOD WIDTH (FEET) = 7.19
AVERAGE FLOW VELOCITY (FEET/SEC.) = 2.06
PRODUCT OF DEPTH&VELOCITY (FT*FT/SEC.) = 0.53
STREET FLOW TRAVEL TIME (MIN.) = 1.03 Tc (MIN.) = 7.40
100 YEAR RAINFALL INTENSITY (INCH/HOUR) = 5.933
*USER SPECIFIED (SUBAREA):
RESIDENTIAL (7.3 DU/AC OR LESS) RUNOFF COEFFICIENT = .6200
S.C.S. CURVE NUMBER (AMC II) = 0
AREA-AVERAGE RUNOFF COEFFICIENT = 0.620
SUBAREA AREA (ACRES) = 0.52 SUBAREA RUNOFF (CFS) = 1.91
TOTAL AREA (ACRES) = 0.6 PEAK FLOW RATE (CFS) = 2.13

END OF SUBAREA STREET FLOW HYDRAULICS:
DEPTH (FEET) = 0.30 HALFSTREET FLOOD WIDTH (FEET) = 9.43
FLOW VELOCITY (FEET/SEC.) = 2.33 DEPTH*VELOCITY (FT*FT/SEC.) = 0.70
LONGEST FLOWPATH FROM NODE 301.00 TO NODE 304.00 = 226.00 FEET.

FLOW PROCESS FROM NODE 304.00 TO NODE 305.00 IS CODE = 31

>>>>COMPUTE PIPE-FLOW TRAVEL TIME THRU SUBAREA<<<<<
>>>>USING COMPUTER-ESTIMATED PIPESIZE (NON-PRESSURE FLOW)<<<<<

=====

ELEVATION DATA: UPSTREAM (FEET) = 175.60 DOWNSTREAM (FEET) = 168.90
FLOW LENGTH (FEET) = 173.00 MANNING'S N = 0.013
DEPTH OF FLOW IN 9.0 INCH PIPE IS 5.4 INCHES
PIPE-FLOW VELOCITY (FEET/SEC.) = 7.70
ESTIMATED PIPE DIAMETER (INCH) = 9.00 NUMBER OF PIPES = 1
PIPE-FLOW (CFS) = 2.13
PIPE TRAVEL TIME (MIN.) = 0.37 Tc (MIN.) = 7.78
LONGEST FLOWPATH FROM NODE 301.00 TO NODE 305.00 = 399.00 FEET.

FLOW PROCESS FROM NODE 305.00 TO NODE 306.00 IS CODE = 31

>>>>COMPUTE PIPE-FLOW TRAVEL TIME THRU SUBAREA<<<<<
>>>>USING COMPUTER-ESTIMATED PIPESIZE (NON-PRESSURE FLOW)<<<<<

=====

ELEVATION DATA: UPSTREAM (FEET) = 168.90 DOWNSTREAM (FEET) = 164.50
FLOW LENGTH (FEET) = 100.00 MANNING'S N = 0.013
DEPTH OF FLOW IN 9.0 INCH PIPE IS 5.2 INCHES
PIPE-FLOW VELOCITY (FEET/SEC.) = 8.09
ESTIMATED PIPE DIAMETER (INCH) = 9.00 NUMBER OF PIPES = 1
PIPE-FLOW (CFS) = 2.13
PIPE TRAVEL TIME (MIN.) = 0.21 Tc (MIN.) = 7.98
LONGEST FLOWPATH FROM NODE 301.00 TO NODE 306.00 = 499.00 FEET.

FLOW PROCESS FROM NODE 306.00 TO NODE 306.00 IS CODE = 81

>>>>ADDITION OF SUBAREA TO MAINLINE PEAK FLOW<<<<<

=====

100 YEAR RAINFALL INTENSITY (INCH/HOUR) = 5.651
*USER SPECIFIED (SUBAREA):
RESIDENTIAL (7.3 DU/AC OR LESS) RUNOFF COEFFICIENT = .6200
S.C.S. CURVE NUMBER (AMC II) = 0
AREA-AVERAGE RUNOFF COEFFICIENT = 0.6200

SUBAREA AREA (ACRES) = 0.49 SUBAREA RUNOFF (CFS) = 1.72
TOTAL AREA (ACRES) = 1.1 TOTAL RUNOFF (CFS) = 3.75
TC (MIN.) = 7.98

FLOW PROCESS FROM NODE 306.00 TO NODE 306.00 IS CODE = 7

>>>>USER SPECIFIED HYDROLOGY INFORMATION AT NODE<<<<<<

=====

USER-SPECIFIED VALUES ARE AS FOLLOWS:
TC (MIN) = 15.38 RAIN INTENSITY (INCH/HOUR) = 3.70
TOTAL AREA (ACRES) = 1.07 TOTAL RUNOFF (CFS) = 0.83

FLOW PROCESS FROM NODE 307.00 TO NODE 308.00 IS CODE = 31

>>>>COMPUTE PIPE-FLOW TRAVEL TIME THRU SUBAREA<<<<<<
>>>>USING COMPUTER-ESTIMATED PIPESIZE (NON-PRESSURE FLOW)<<<<<<

=====

ELEVATION DATA: UPSTREAM (FEET) = 161.00 DOWNSTREAM (FEET) = 146.20
FLOW LENGTH (FEET) = 182.00 MANNING'S N = 0.013
DEPTH OF FLOW IN 6.0 INCH PIPE IS 3.1 INCHES
PIPE-FLOW VELOCITY (FEET/SEC.) = 8.05
ESTIMATED PIPE DIAMETER (INCH) = 6.00 NUMBER OF PIPES = 1
PIPE-FLOW (CFS) = 0.83
PIPE TRAVEL TIME (MIN.) = 0.38 Tc (MIN.) = 15.76
LONGEST FLOWPATH FROM NODE 301.00 TO NODE 308.00 = 681.00 FEET.

FLOW PROCESS FROM NODE 308.00 TO NODE 309.00 IS CODE = 31

>>>>COMPUTE PIPE-FLOW TRAVEL TIME THRU SUBAREA<<<<<<
>>>>USING COMPUTER-ESTIMATED PIPESIZE (NON-PRESSURE FLOW)<<<<<<

=====

ELEVATION DATA: UPSTREAM (FEET) = 146.20 DOWNSTREAM (FEET) = 144.80
FLOW LENGTH (FEET) = 194.00 MANNING'S N = 0.013
DEPTH OF FLOW IN 9.0 INCH PIPE IS 5.1 INCHES
PIPE-FLOW VELOCITY (FEET/SEC.) = 3.24
ESTIMATED PIPE DIAMETER (INCH) = 9.00 NUMBER OF PIPES = 1
PIPE-FLOW (CFS) = 0.83
PIPE TRAVEL TIME (MIN.) = 1.00 Tc (MIN.) = 16.76
LONGEST FLOWPATH FROM NODE 301.00 TO NODE 309.00 = 875.00 FEET.

FLOW PROCESS FROM NODE 309.00 TO NODE 310.00 IS CODE = 31

>>>>COMPUTE PIPE-FLOW TRAVEL TIME THRU SUBAREA<<<<<<
>>>>USING COMPUTER-ESTIMATED PIPESIZE (NON-PRESSURE FLOW)<<<<<<

=====

ELEVATION DATA: UPSTREAM (FEET) = 144.80 DOWNSTREAM (FEET) = 135.20
FLOW LENGTH (FEET) = 184.00 MANNING'S N = 0.013
DEPTH OF FLOW IN 6.0 INCH PIPE IS 3.6 INCHES
PIPE-FLOW VELOCITY (FEET/SEC.) = 6.83
ESTIMATED PIPE DIAMETER (INCH) = 6.00 NUMBER OF PIPES = 1
PIPE-FLOW (CFS) = 0.83
PIPE TRAVEL TIME (MIN.) = 0.45 Tc (MIN.) = 17.21
LONGEST FLOWPATH FROM NODE 301.00 TO NODE 310.00 = 1059.00 FEET.

FLOW PROCESS FROM NODE 310.00 TO NODE 310.00 IS CODE = 1

>>>>DESIGNATE INDEPENDENT STREAM FOR CONFLUENCE<<<<<<
>>>>AND COMPUTE VARIOUS CONFLUENCED STREAM VALUES<<<<<<

=====

TOTAL NUMBER OF STREAMS = 2
CONFLUENCE VALUES USED FOR INDEPENDENT STREAM 2 ARE:
TIME OF CONCENTRATION (MIN.) = 17.21
RAINFALL INTENSITY (INCH/HR) = 3.44
TOTAL STREAM AREA (ACRES) = 1.07
PEAK FLOW RATE (CFS) AT CONFLUENCE = 0.83

** CONFLUENCE DATA **

STREAM NUMBER	RUNOFF (CFS)	Tc (MIN.)	INTENSITY (INCH/HOUR)	AREA (ACRE)
1	5.21	12.35	4.264	2.85
2	0.83	17.21	3.443	1.07

RAINFALL INTENSITY AND TIME OF CONCENTRATION RATIO
CONFLUENCE FORMULA USED FOR 2 STREAMS.

** PEAK FLOW RATE TABLE **

STREAM NUMBER	RUNOFF (CFS)	Tc (MIN.)	INTENSITY (INCH/HOUR)
1	5.81	12.35	4.264
2	5.04	17.21	3.443

COMPUTED CONFLUENCE ESTIMATES ARE AS FOLLOWS:

PEAK FLOW RATE (CFS) = 5.81 Tc (MIN.) = 12.35
TOTAL AREA (ACRES) = 3.9
LONGEST FLOWPATH FROM NODE 301.00 TO NODE 310.00 = 1059.00 FEET.

FLOW PROCESS FROM NODE 310.00 TO NODE 311.00 IS CODE = 31

>>>>COMPUTE PIPE-FLOW TRAVEL TIME THRU SUBAREA<<<<<
>>>>USING COMPUTER-ESTIMATED PIPESIZE (NON-PRESSURE FLOW)<<<<<

=====

ELEVATION DATA: UPSTREAM (FEET) = 135.20 DOWNSTREAM (FEET) = 135.00
FLOW LENGTH (FEET) = 44.00 MANNING'S N = 0.013
DEPTH OF FLOW IN 18.0 INCH PIPE IS 12.6 INCHES
PIPE-FLOW VELOCITY (FEET/SEC.) = 4.38
ESTIMATED PIPE DIAMETER (INCH) = 18.00 NUMBER OF PIPES = 1
PIPE-FLOW (CFS) = 5.81
PIPE TRAVEL TIME (MIN.) = 0.17 Tc (MIN.) = 12.52
LONGEST FLOWPATH FROM NODE 301.00 TO NODE 311.00 = 1103.00 FEET.

FLOW PROCESS FROM NODE 311.00 TO NODE 311.00 IS CODE = 1

>>>>DESIGNATE INDEPENDENT STREAM FOR CONFLUENCE<<<<<

=====

TOTAL NUMBER OF STREAMS = 2
CONFLUENCE VALUES USED FOR INDEPENDENT STREAM 1 ARE:
TIME OF CONCENTRATION (MIN.) = 12.52
RAINFALL INTENSITY (INCH/HR) = 4.23
TOTAL STREAM AREA (ACRES) = 3.92
PEAK FLOW RATE (CFS) AT CONFLUENCE = 5.81

FLOW PROCESS FROM NODE 311.00 TO NODE 311.00 IS CODE = 7

>>>>USER SPECIFIED HYDROLOGY INFORMATION AT NODE<<<<<

=====

USER-SPECIFIED VALUES ARE AS FOLLOWS:
TC (MIN) = 7.66 RAIN INTENSITY (INCH/HOUR) = 5.80
TOTAL AREA (ACRES) = 0.84 TOTAL RUNOFF (CFS) = 3.41

FLOW PROCESS FROM NODE 311.00 TO NODE 311.00 IS CODE = 1

>>>>DESIGNATE INDEPENDENT STREAM FOR CONFLUENCE<<<<<
>>>>AND COMPUTE VARIOUS CONFLUENCED STREAM VALUES<<<<<

=====

TOTAL NUMBER OF STREAMS = 2
CONFLUENCE VALUES USED FOR INDEPENDENT STREAM 2 ARE:
TIME OF CONCENTRATION (MIN.) = 7.66
RAINFALL INTENSITY (INCH/HR) = 5.80
TOTAL STREAM AREA (ACRES) = 0.84
PEAK FLOW RATE (CFS) AT CONFLUENCE = 3.41

** CONFLUENCE DATA **

STREAM	RUNOFF	Tc	INTENSITY	AREA
--------	--------	----	-----------	------

NUMBER	(CFS)	(MIN.)	(INCH/HOUR)	(ACRE)
1	5.81	12.52	4.228	3.92
2	3.41	7.66	5.803	0.84

RAINFALL INTENSITY AND TIME OF CONCENTRATION RATIO
 CONFLUENCE FORMULA USED FOR 2 STREAMS.

** PEAK FLOW RATE TABLE **

STREAM NUMBER	RUNOFF (CFS)	Tc (MIN.)	INTENSITY (INCH/HOUR)
1	7.64	7.66	5.803
2	8.29	12.52	4.228

COMPUTED CONFLUENCE ESTIMATES ARE AS FOLLOWS:

PEAK FLOW RATE (CFS) = 8.29 Tc (MIN.) = 12.52
 TOTAL AREA (ACRES) = 4.8
 LONGEST FLOWPATH FROM NODE 301.00 TO NODE 311.00 = 1103.00 FEET.

=====
 END OF STUDY SUMMARY:

TOTAL AREA (ACRES) = 4.8 TC (MIN.) = 12.52
 PEAK FLOW RATE (CFS) = 8.29

=====
 END OF RATIONAL METHOD ANALYSIS

ATTACHMENT 6
Geotechnical and Groundwater Investigation Report

This is the cover sheet for Attachment 6.





**PRELIMINARY GEOTECHNICAL EVALUATION
FOR
PROPOSED GUAJOME CREST DEVELOPMENT
APN 157-412-15
NORTHEAST OF ALBRIGHT STREET AND GAUJOME LAKE ROAD
OCEANSIDE CALIFORNIA 92008**

**PREPARED FOR
RINCON HOMES
5315 AVENIDA ENCINAS, SUITE 200
CARLSBAD, CALIFORNIA 92008**

**PREPARED BY
GEOTEK, INC.
1384 POINSETTIA AVENUE, SUITE A
VISTA, CALIFORNIA 92081**

PROJECT No. 3775-SD

MAY 19, 2022



GeoTek, Inc.
1384 Poinsettia Avenue, Suite A Vista, CA 92081-8505
(760) 599-0509 Office (760) 599-0593 Fax www.geotekusa.com

May 19, 2022
Project No. 3775-SD

Rincon Homes

5315 Avenida Encinas, Suite 200
Carlsbad, California 92008

Attention: Mr. Cameron St. Clair

Subject: **Preliminary Geotechnical Evaluation**
Proposed Guajome Crest Development
Northeast of Albright Street and Guajome Lake Road
APN 157-412-15
Oceanside, California 92057

Dear Mr. St. Clair:

GeoTek, Inc. (GeoTek) is pleased to provide herein the results of a preliminary geotechnical evaluation for the subject project located in the City of Oceanside, California. This report presents the results of GeoTek's evaluation and provides preliminary geotechnical recommendations for earthwork, foundation design, and construction. Based upon review, site development appears feasible from a geotechnical viewpoint provided that the recommendations included herein are incorporated into the design and construction phases of site development.

The opportunity to be of service is sincerely appreciated. If you should have any questions, please do not hesitate to call GeoTek.

Respectfully submitted,
GeoTek, Inc.



Christopher D. Livesey
CEG 2733
Associate Vice President



Farhad Bastani
RCE 79962
Project Engineer



TABLE OF CONTENTS

1. PURPOSE AND SCOPE OF SERVICES	1
2. SITE DESCRIPTION AND PROPOSED DEVELOPMENT	1
2.1 SITE DESCRIPTION	1
2.2 PROPOSED DEVELOPMENT	2
3. FIELD EXPLORATION AND LABORATORY TESTING	2
3.1 FIELD EXPLORATION	2
3.2 PERCOLATION TESTING	3
3.3 LABORATORY TESTING	3
4. GEOLOGIC AND SOILS CONDITIONS	4
4.1 REGIONAL SETTING	4
4.2 EARTH MATERIALS	4
4.2.1 Hydrological Classification	4
4.2.2 Quaternary-age Alluvium (Map Symbol Qal)	4
4.2.3 Quaternary-age Colluvium (Map Symbol Qcol)	5
4.2.4 Tertiary-age Santiago Formation (Map Symbol Tsa)	5
4.3 SURFACE WATER AND GROUNDWATER	5
4.3.1 Surface Water	5
4.3.2 Groundwater	5
4.4 EARTHQUAKE HAZARDS	5
4.4.1 Surface Fault Rupture	5
4.4.2 Liquefaction/Seismic Settlement	6
4.4.3 Other Seismic Hazards	6
5. CONCLUSIONS AND RECOMMENDATIONS	6
5.1 GENERAL	6
5.2 EARTHWORK CONSIDERATIONS	6
5.2.1 General	6
5.2.2 Site Clearing and Preparation	7
5.2.3 Remedial Grading	7
5.2.4 Cut/Fill Transition Lots	7
5.2.5 Cut Lots	7
5.2.6 Engineered Fill	7
5.2.7 Slope Construction	8
5.2.8 Excavation Characteristics	8
5.2.9 Shrinkage and Bulking	9
5.2.10 Trench Excavations and Backfill	9
5.3 DESIGN RECOMMENDATIONS	10
5.3.1 Stormwater Infiltration	10
5.3.2 Foundation Design Criteria	12
5.3.3 Under Slab Moisture Membrane	14
5.3.4 Miscellaneous Foundation Recommendations	15
5.3.5 Foundation Setbacks	15
5.3.6 Seismic Design Parameters	16
5.3.7 Soil Sulfate Content and Corrosivity	16
5.3.8 Preliminary Pavement Design	17
5.3.9 Portland Cement Concrete (PCC)	18

TABLE OF CONTENTS

5.4	RETAINING WALL DESIGN AND CONSTRUCTION	18
5.4.1	General Design Criteria	18
5.4.2	Restrained Retaining Walls	19
5.4.3	Wall Backfill and Drainage	19
6.	CONCRETE FLATWORK.....	20
6.1	GENERAL CONCRETE FLATWORK	20
6.1.1	Exterior Concrete Slabs and Sidewalks	20
6.1.2	Concrete Performance	20
7.	POST CONSTRUCTION CONSIDERATIONS	21
7.1	LANDSCAPE MAINTENANCE AND PLANTING	21
7.2	DRAINAGE	22
7.3	PLAN REVIEW AND CONSTRUCTION OBSERVATIONS.....	22
8.	LIMITATIONS	23
9.	SELECTED REFERENCES.....	24

ENCLOSURES

Figure 1 – Site Location Map

Figure 2 – Geotechnical Map

Appendix A – Logs of Exploration and Percolation Logs

Appendix B – Results of Laboratory Testing

Appendix C – General Earthwork Grading Guidelines

I. PURPOSE AND SCOPE OF SERVICES

The purpose of this study was to evaluate the geotechnical conditions of the project site. Services provided for this study included the following:

- Research and review of available geologic and geotechnical data, and general information pertinent to the site.
- Excavation of nine exploratory test pits and collection of bulk soil samples for subsequent laboratory testing.
- Excavation of three auger drilled test holes for subsequent percolation testing.
- Laboratory testing of the soil samples collected during the field investigation.
- Compilation of this geotechnical report which presents GeoTek's findings of pertinent site geotechnical conditions and geotechnical recommendations for site development.

2. SITE DESCRIPTION AND PROPOSED DEVELOPMENT

2.1 SITE DESCRIPTION

The subject property is located east of Albright Street and north of Guajome Lake Road in the City of Oceanside, California (see Figure 1). The proposed development is limited to within the southern portion of County of San Diego Assessor's Parcel Number 157-412-15, adjacent to 2837 Guajome Lake Road (see Figure 2), herein referred to as the subject site or site. The subject site is bounded to the north by a descending slope to natural drainage where a single family dwelling and detached storage/maintenance building has been built, to the west-northwest and southeast by residential property, and to the south by Guajome Lake Road. A dirt driveway off of Guajome Lake Road provides access across the site. The site is currently vacant with a ridge that divides the property. Topography of the site gently descending from the northeast to the southwest at an approximate 4:1 (horizontal:vertical) and the north side of the ridge descends at an approximate 3:1. Elevations range from 189 feet above mean sea level (msl) at the top of the ridge to an approximate elevation of 141 msl along Guajome Lake Road. Surface drainage is directed towards the southwest and northeast on their respective ridge sides.

2.2 PROPOSED DEVELOPMENT

Based on the preliminary layout plan provided by Pasco Laret Suiter and Associates (PLSA, 2022), proposed improvements include 84 single family residences, a main road circling through the subject property connected to Guajome Lake Road, retaining walls, an open space lot, sidewalk, and two stormwater basins. Assumed improvements are considered to include two-story single family residential buildings, underground wet and dry utilities and landscaping. The building pads range in size between 2,496 and 5,664 square feet. Cuts and fills of up to 24 and 14 feet (respectively) are anticipated with an approximate 67,000 cubic yards of export material. A maximum fill slope of 50 feet is proposed in the north, although it appears to be thin veneer fill slope. A maximum cut slope of 12 feet is proposed in the east portion of the site. The slopes are proposed to be constructed at a 2:1. Retaining walls are proposed to be 5 feet max.

It is anticipated that the residential buildings will be of wood frame construction and will be supported by conventional shallow foundations (continuous and isolated pad) and a conventional slab on-grade or raised-wood floor. For the purposes of this report, it is assumed maximum column and wall loads will be approximately 25 kips and 2 kips per foot, respectively. Once actual loads are known that information should be provided to GeoTek to determine if modifications to the recommendations presented in this report are warranted.

As site planning progresses and additional or revised plans become available, they should be provided to GeoTek for review and comment. If plans vary significantly, additional geotechnical field exploration, laboratory testing and engineering analyses may be necessary to provide specific earthwork recommendations and geotechnical design parameters for actual site development plans.

3. FIELD EXPLORATION AND LABORATORY TESTING

3.1 FIELD EXPLORATION

GeoTek's field study, conducted on March 29th, 2022, consisted of a site reconnaissance and excavation of nine exploratory test pits with a rubber tracked CAT 305.5E (mini) excavator. Test pits TP-1 through TP-9 were excavated to depths ranging between 6.5 to 8 feet below existing grade. Excavation of three auger borings, P-1 through P-3, to depths ranging between 4 to 5 feet below grade were performed for subsequent percolation testing. A representative from GeoTek visually logged the test pits, collected loose bulk soil samples for laboratory analysis, and transported the samples to GeoTek's laboratory. Percolation tests were performed the following day. Approximate locations of the exploratory test pits and percolation test holes are presented



on the Geotechnical Map, Figure 2. A description of material encountered in the test pits is included in Appendix A.

3.2 PERCOLATION TESTING

Three percolation borings (Borings P-1 through P-3) were excavated to depths approximately 50.5 to 55 inches below the existing ground surface. The boring bottom and side walls were scarified and cleaned as feasible of potential drilling fines adhered to the boring walls. The test hole was then filled with potable water to pre-soak. Following overnight pre-soaking, the test holes were filled with water and the drop in water level was recorded every 30 minutes. The test was continued for a minimum of nine readings and the final reading was used in the calculation of the infiltration rate. The field data was converted to an infiltration rate via the Porchet method. Over the lifetime of the storm water disposal areas, the infiltration rates may be affected by silt build up and biological activities, as well as local variations in near surface soil conditions. The rates presented below do not include a factor of safety, the BMP designer should include appropriate factors of safety in their design.

INFILTRATION TEST RESULTS		
Test No.	Approximate Boring Depth (Inches)	Infiltration Rate (Inches per hour)
P-1	55	0.08
P-2	50.5	0.80
P-3	52	0.45

Copies of the percolation data sheets and infiltration conversion sheets (Porchet Method) are included in Appendix A.

3.3 LABORATORY TESTING

Laboratory testing was performed on bulk soil samples collected during the field explorations. The purpose of the laboratory testing was to evaluate their physical and chemical properties for use in engineering design and analysis. Results of the laboratory testing program, along with a brief description and relevant information regarding testing procedures, are included in Appendix B.

4. GEOLOGIC AND SOILS CONDITIONS

4.1 REGIONAL SETTING

The subject property is located in the Peninsular Ranges geomorphic province. The Peninsular Ranges province is one of the largest geomorphic units in western North America. It extends roughly 975 miles from the north and northeasterly adjacent the Transverse Ranges geomorphic province to the peninsula of Baja California. This province varies in width from about 30 to 100 miles. It is bounded on the west by the Pacific Ocean, on the south by the Gulf of California and on the east by the Colorado Desert Province.

The Peninsular Ranges are essentially a series of northwest-southeast oriented fault blocks. Several major fault zones are found in this province. The Elsinore Fault zone and the San Jacinto Fault zones trend northwest-southeast and are found in the near the middle of the province. The San Andreas Fault zone borders the northeasterly margin of the province. The Newport-Inglewood-Rose Canyon Fault zone meanders the southwest margin of the province. No faults are shown in the immediate site vicinity on the map reviewed for the area.

4.2 EARTH MATERIALS

A brief description of the earth materials encountered during the current subsurface exploration is presented in the following sections. Based on the field observations and review of published geologic maps the subject site is locally underlain by a thin layer of quaternary alluvium over Santiago Formation.

4.2.1 Hydrological Classification

The site is mapped as Los Flores Series which consists of “a member of the fine, montmorillonitic, thermic family of Natric Palexeralfs. Typically, Las Flores soils have light brownish gray, slightly and medium acid, loamy sand A horizons, grayish brown and light brownish gray, slightly acid and neutral, sandy clay B2t horizons grading to weakly consolidated siliceous marine sandstone” (UCDavis, 1997). The hydrologic classification of the Los Flores Series is a Group “D”.

4.2.2 Quaternary-age Alluvium (Map Symbol Qal)

Quaternary alluvium was encountered in test pits TP-2 and TP-9 up to 2 feet deep from existing grades. The alluvium consisted of silty fine to medium sand, damp, loose, with some surficial vegetation and roots in the upper 6 inches (SM soil type based upon the Unified Soil Classification System). The alluvium was observed to be slightly porous and unconsolidated. The alluvium was observed to be confined to the natural drainage swales.

4.2.3 Quaternary-age Colluvium (Map Symbol Qcol)

Quaternary colluvium was encountered in test pits TP-1 and TP-3 through TP-8 generally 1-2 feet thick, but was observed to be 3 feet thick at location TP-6. The colluvium consisted of silty fine to medium sand, light brown to dark brown in color, damp to moist, loose, and some surficial vegetation and roots in the upper 6 inches (SM soil type based upon the Unified Soil Classification System, USCS). The colluvium was also observed to be slightly porous and unconsolidated.

4.2.4 Tertiary-age Santiago Formation (Map Symbol Tsa)

Tertiary-age Santiago Formation was encountered in all test pits, to the full depth of exploration, which ranged approximately between 1 and 8 feet below existing grades. This material consisted of fine to coarse sandstone with some gravels (SW soil type based upon USCS), light tan with orange oxidization in color, dry, an increase in density with depth, and quartz rich. The formation was found to be slightly weathered at the upper one foot but became less weathered with depth. All test pits were terminated shallow of maximum equipment reach due to refusal of advancement. Occasional pockets of siltstone (rip up clasts) were interspersed throughout the formation and observed in test pits TP-3 through TP-9.

4.3 SURFACE WATER AND GROUNDWATER

4.3.1 Surface Water

Surface water was not observed during the recent site exploration. If encountered during earthwork construction, surface water on this site will most likely be the result of precipitation. Overall site area drainage is in a southwestern direction. Provisions for surface drainage will need to be accounted for by the project civil engineer.

4.3.2 Groundwater

No groundwater was encountered during exploration of the subject site. Based on the anticipated depth of removals, groundwater is not anticipated to be a factor in site development. Localized perched groundwater may be present but is also not anticipated to be a factor in site development.

4.4 EARTHQUAKE HAZARDS

4.4.1 Surface Fault Rupture

The geologic structure of the entire southern California area is dominated mainly by northwest-trending faults associated with the San Andreas system. The site is not in a seismically active region. No active or potentially active fault is known to exist at this site nor is the site situated within an "Alquist-Priolo" Earthquake Fault Zone or a Special Studies Zone (Bryant and Hart, 2007). No faults transecting the site were identified on the readily available geologic maps reviewed.

The nearest known active fault is the Newport Inglewood-Rose Canyon fault located about 10.4 miles to the southwest of the site.

4.4.2 Liquefaction/Seismic Settlement

Liquefaction describes a phenomenon in which cyclic stresses, produced by earthquake-induced ground motion, create excess pore pressures in relatively cohesionless soils. These soils may thereby acquire a high degree of mobility, which can lead to lateral movement, sliding, consolidation and settlement of loose sediments, sand boils and other damaging deformations. This phenomenon occurs only below the water table, but, after liquefaction has developed, the effects can propagate upward into overlying non-saturated soil as excess pore water dissipates.

The factors known to influence liquefaction potential include soil type and grain size, relative density, groundwater level, confining pressures, and both intensity and duration of ground shaking. In general, materials that are susceptible to liquefaction are loose, saturated granular soils having low fines content under low confining pressures.

The liquefaction potential and seismic settlement potential on this site is considered negligible due to the apparent density of the underlying formation and lack of a shallow groundwater table.

4.4.3 Other Seismic Hazards

The potential for landslides and rockfall is considered negligible. The potential for secondary seismic hazards such as seiche and tsunami is remote due to site elevation and distance from an open body of water.

5. CONCLUSIONS AND RECOMMENDATIONS

5.1 GENERAL

Development of the site appears feasible from a geotechnical viewpoint provided that the following recommendations are incorporated in the design and construction phases of the development. The following sections present general recommendations for currently anticipated site development plans.

5.2 EARTHWORK CONSIDERATIONS

5.2.1 General

Earthwork and grading should be performed in accordance with the applicable grading ordinances of the City of Oceanside, the 2019 (or current) California Building Code (CBC), and

recommendations contained in this report. The Grading Guidelines included in Appendix C outline general procedures and do not anticipate all site-specific situations. In the event of conflict, the recommendations presented in the text of this report should supersede those contained in Appendix C.

5.2.2 Site Clearing and Preparation

Site preparation should start with removal of deleterious materials, vegetations, and trees/shrubs in the proposed improvement areas. These materials should be disposed of properly off site. Any existing underground improvements, utilities and trench backfill should also be removed or be further evaluated as part of site development operations.

5.2.3 Remedial Grading

Prior to placement of fill materials and in all structural areas, the upper variable, potentially compressible materials should be removed. Removals should include at a minimum all alluvium and colluvium and the upper 2 to 3 feet of weathered Santiago Formation below existing grade. Based on the explored locations, and average removal depth of 3 feet from existing grades may be anticipated, but does not include stabilization fill keys. The bottom of the removals should be observed by a GeoTek representative prior to processing the bottom for receiving placement of compacted fills. Depending on actual field conditions encountered during grading, locally deeper and/or shallower areas of removal may be necessary.

Prior to fill placement, the bottom of all removals should be scarified to a minimum depth of six (6) inches, moisture conditioned to slightly above optimum moisture content, and then compacted to at least 90% of the soil's maximum dry density as determined by ASTM D1557 test procedures. The resultant voids from remedial grading/over-excavation should be filled with materials placed in general accordance with Section 5.2.6 Engineered Fill of this report.

5.2.4 Cut/Fill Transition Lots

Grading may result in a cut/fill transition at the proposed building pad finish grades. If a geologic contact of Santiago bedrock against fills is encountered at finish pad grades, the cut portion should be over-excavated a minimum of three feet below pad grades and replaced with engineered fill.

5.2.5 Cut Lots

Lots wholly excavated in a cut condition exposing sandstone of the Santiago Formation may remain as a cut lot, however, this may pose difficult excavation during post-grading and inhibit landscape growth.

5.2.6 Engineered Fill

Onsite materials are generally considered suitable for reuse as engineered fill provided they are free from vegetation, roots, debris, and rock/concrete or hard lumps greater than six (6) inches

in maximum dimension. The earthwork contractor should have the proposed excavated materials to be used as engineered fill at this project approved by the soils engineer prior to placement.

Engineered fill materials should be moisture conditioned to at or above optimum moisture content and compacted in horizontal lifts not exceeding 8 inch in loose thickness to a minimum relative compaction of 90% as determined by ASTM D1557 test procedures.

If fill is being placed on slopes steeper than 5:1 (horizontal : vertical), the fill should be properly benched into the existing slopes and a sufficient size keyway shall be constructed in accordance with grading guidelines presented in Appendix C.

5.2.7 Slope Construction

An engineering geologist should observe all cut slopes. Cut slopes should expose competent bedrock. If adverse structure or unsuitable materials are exposed and identified in the cut slopes, stabilization fills may be recommended.

Where fill is to be placed against sloping ground with gradients of 5:1 (h:v) or steeper, the sloping ground surface should be benched to provide horizontal surfaces for fill placement. A keyway should be constructed at the toe of the fill slope areas into dense natural material and in accordance with Plate G-3, Appendix C.

The base of the keyways and benches should be sloped back into the hillside at a gradient of at least two percent. The base of the benches should be evaluated by a representative of GeoTek prior to processing. Upon approval, the exposed materials should be moistened to at least the optimum moisture content and densified to a relative compaction of at least 90 percent (ASTM D1557). Details showing slope construction are presented in Appendix C.

Fill slopes should be overfilled during construction and then cut back to expose compacted soil. A suitable alternative would be to compact the slopes during construction and then roll the final slope to provide a dense, erosion resistant surface.

Back drains should be installed in the keyways in accordance with the recommendations outlined in Appendix C.

5.2.8 Excavation Characteristics

Excavations in the onsite materials can generally be accomplished with heavy-duty earthmoving or excavating equipment in good operating condition. The upper zone of the Santiago Formation is anticipated to be rippable with conventional heavy earth moving equipment in good working

order. As mentioned in Section 5.2.5, lots wholly excavated in a cut condition exposing sandstone of the Santiago Formation may pose difficult excavation during post-grading and inhibit landscape growth.

5.2.9 Shrinkage and Bulking

Several factors will impact earthwork balancing on the site, including undocumented fill shrinkage, trench spoil from utilities and footing excavations, as well as the accuracy of topography.

Shrinkage and bulking are largely dependent upon the degree of compactive effort achieved during construction. For planning purposes, a shrinkage factor of 5 percent may be considered for fills generated from alluvial and colluvial sources. For excavations in the sandstone, a bulking factor of 10 percent may be considered. Subsidence should not be a factor on the subject site due to the presence of bedrock if removals are completed as recommended.

5.2.10 Trench Excavations and Backfill

Temporary excavations within the onsite materials should be stable at 1:1 inclinations for short durations during construction, and where cuts do not exceed 10 feet in height. Temporary cuts to a maximum height of 4 feet can be excavated vertically.

Trench excavations should conform to Cal-OSHA regulations. The contractor should have a competent person, per OSHA requirements, on site during construction to observe conditions and to make the appropriate recommendations.

Utility trench backfill should be compacted to at least 90% relative compaction of the maximum dry density as determined by ASTM D1557 test procedures. Under-slab trenches should also be compacted to project specifications.

Onsite materials may not be suitable for use as bedding material but should be suitable as backfill provided particles larger than $6\pm$ inches are removed.

Compaction should be achieved with a mechanical compaction device. Ponding or jetting of trench backfill is not recommended. If backfill soils have dried out, they should be thoroughly moisture conditioned prior to placement in trenches.

5.3 DESIGN RECOMMENDATIONS

5.3.1 Stormwater Infiltration

Many factors control infiltration of surface waters into the subsurface, such as consistency of native soils and bedrock, geologic structure, fill consistency, material density differences, and existing groundwater conditions.

The hydrological unit as mapped by the USDA is a group “D”. Percolation testing and infiltration analysis indicates that the site could be considered to be classified as a hydrological group B, which consist of soils that are deeper than 40 inches to a water impermeable layer and a water table are in group B if the saturated hydraulic conductivity of all soil layers within 40 inches of the surface is between 0.57 and 1.42 inches per hour.

The percolation tests were performed in areas of natural drainage. Drainage environment characteristics should not be correlated to colluvial or Santiago Formation. Areas outside alluvial areas in drainage swales are considered to be consistent with hydrological group “D”.

Discussions were performed with the BMP design team (PLSA), regarding proposed locations. No reasonable alternative design location is feasible, from the locations presented on Figure 2. GeoTek has reviewed mandatory consideration and optional considerations as recommended in the City of Oceanside BMP design Manual and are outlined as follows:

5.3.1.1 Is the BMP within 100 feet of contaminated soils.

A review of GeoTracker.com, did not present a source of uncontrolled contaminant release within 100 feet of the proposed BMP basins.

5.3.1.2 Is the BMP within 100 feet of industrial activities lacking source control.

A review of GeoTracker.com, did not present a source of uncontrolled contaminant release within 100 feet of the proposed BMP basins.

5.3.1.3 Is the BMP within 100 feet of well/groundwater basin

A review of Geotracker.com and California Water Resources Board interactive well and groundwater maps did not identify well or groundwater data information on or nearby the site. Groundwater was not encountered in during GeoTek’s field exploration.

5.3.1.4 Is the BMP within 50 feet of septic tanks/leach fields.

Based on a review of the site and historical aerial and satellite imagery, septic tanks/leach fields are not anticipated to be within 50 feet of the BMPs nor on site.

5.3.1.5 Is the BMP within 10 feet of structures/tanks/walls

Based on the proposed development, the BMP is not located within 10 feet of structures/tanks/walls. It is common for basins to require retaining walls, if progressive design includes walls within 10 feet of the basin, a no infiltration is recommended.

5.3.1.6 Is the BMP within 10 feet of sewer utilities.

The proposed BMP is within 10 feet of a street. Sewer utilities have not yet been design, but are not always along the center of a street's alignment.

5.3.1.7 Is the BMP within 10 feet of groundwater.

Groundwater was not encountered during GeoTek's field exploration. Near the proposed BMPs to depths explored of 6.5 feet below existing ground surface. Considering the grades at the proposed basin are elevated and a typical five foot bottom of basin, no groundwater is anticipated to be present within ten feet of the BMP.

5.3.1.8 Is the BMP within hydric soils

Hydric soils are environments where low oxygen soil environment exists due to long term saturation of soils. Sloping topography of the site does not provide an environment that promotes hydric soils.

5.3.1.9 Is the BMP within highly liquefiable soils and has connectivity to structures.

Santiago formational soils are within the near surface and are not susceptible to liquefaction.

5.3.1.10 Is the BMP within 1.5 times the height of adjacent steep slopes ($\geq 25\%$).

The BMP is located within 1.5 times the height of an adjacent steep slope.

5.3.1.11 Has City staff assigned "Restricted" infiltration category.

GeoTek is not aware that City staff have assigned a restricted infiltration category to the site.

5.3.1.12 Is the BMP within fill depths of ≥ 5 feet (existing or proposed).

In the areas of the BMPs remedial grading quantities of approximately three feet plus design fills of seven feet for a fill column of ten feet. Anticipating a bottom of basin depth of five feet, there is still approximately five feet of structural fills underneath the BMP.

GeoTek does not recommend full or partial infiltration. Concentrated infiltration of surface waters has the potential to change the soil strength and unit weight which can result in an increase of seepage forces to the fill slopes within the subject site. These adverse effects can increase risk of slope instability. We recommend filtration of stormwater in lieu of infiltration.

5.3.2 Foundation Design Criteria

Preliminary foundation design criteria, in general conformance with the 2019 CBC, are presented herein. These are typical design criteria and are not intended to supersede the design by the structural engineer. The preliminary recommendations presented below.

Based on visual classification of materials encountered onsite and as verified by laboratory testing, site soils are anticipated to exhibit a “very low” ($EI < 20$) expansion index per ASTM D4829. Additional laboratory testing should be performed at the time of supplemental geotechnical evaluations and upon completion of site grading to verify the expansion potential and plasticity index of the subgrade soils. The following criteria for design of foundations are preliminary. Additional laboratory testing of the samples obtained during grading should be performed and final recommendations should be based on as-graded soil conditions.

DESIGN PARAMETERS FOR CONVENTIONALLY REINFORCED SHALLOW FOUNDATIONS		
DESIGN PARAMETER	DESIGN PARAMETERS FOR TYPICAL 2-STORY FOUNDATION	DESIGN PARAMETERS FOR TYPICAL 2-STORY FOUNDATION
Expansion Potential	“Very Low” Expansion Potential (EI ≤ 20)	“Low” Expansion Potential (21 ≤ EI ≤ 50)
Foundation Embedment Depth or Minimum Perimeter Beam Depth (inches below lowest adjacent finished grade)	18 - Inches	24 - Inches
Minimum Foundation Width for continuous / perimeter footings*	15 - Inches	15 - Inches
Minimum Foundation Width for isolated / column footings*	24 – Inches (Square)	24 – Inches (Square)
Minimum Slab Thickness (actual)	4 inches	4 inches
Minimum Slab Reinforcing	6” x 6” – W.1.4/W1.4 welded wire fabric, or No. 3 rebar 18” on-center, each way, placed in the middle one-third of the slab thickness	No. 3 rebar 18” on-center, each way, placed in the middle one-third of the slab thickness
Minimum Footing Reinforcement	Two No. 4 reinforcing bars, one top and one bottom	Two No. 4 reinforcing bars, one top and one bottom
Pre-saturation of Subgrade Soil (percent of optimum moisture content)	Minimum 100% to a depth of 12 inches	Minimum 110% to a depth of 12 inches

*Code minimums per Table 1809.7 of the 2019 CBC should be complied with.

It should be noted that the above recommendations are based on soil support characteristics only. The structural engineer should design the slab and beam reinforcement based on actual loading conditions.

The following recommendations should be implemented into the design:

- An allowable bearing capacity of 2,000 pounds per square foot (psf) may be considered for design of continuous and perimeter footings that meet the depth and width requirements in the table above. This value may be increased by 300 psf for each additional 12 inches in depth and 300 psf for each additional 12 inches in width to a maximum value of 3,000 psf. Additionally, an increase of one-third may be applied when considering short-term live loads (e.g., seismic and wind loads). It may be possible to utilize a higher allowable soil bearing pressure for foundations directly supported by bedrock. The determination of an allowable soil bearing pressure on bedrock should be determined once foundation loads and elevations are known.
- Structural foundations may be designed in accordance with 2019 CBC, and to withstand a total settlement of 1 inch and maximum differential settlement of one-

half of the total settlement over a horizontal distance of 40 feet. Seismically induced settlement is considered to be minimal.

- The passive earth pressure may preliminarily be computed as an equivalent fluid having a density of 350 psf per foot of depth, to a maximum earth pressure of 2,000 psf for footings founded on engineered fill. A coefficient of friction between soil and concrete of 0.35 may be used with dead load forces. When combining passive pressure and frictional resistance, the passive pressure component should be reduced by one-third.
- A grade beam should be utilized across large entrances. The beam should be a minimum of 12 inches wide and be at the same elevation as the bottom of the adjoining footings.

5.3.3 Under Slab Moisture Membrane

A moisture and vapor retarding system should be placed below slabs-on-grade where moisture migration through the slab is undesirable. Guidelines for these are provided in the 2019 California Green Building Standards Code (CALGreen) Section 4.505.2 and the 2019 CBC Section 1907.1

It should be realized that the effectiveness of the vapor retarding membrane can be adversely impacted as a result of construction related punctures (e.g., stake penetrations, tears, punctures from walking on the vapor retarder placed atop the underlying aggregate layer, etc.). These occurrences should be limited as much as possible during construction. Thicker membranes are generally more resistant to accidental puncture than thinner ones. Products specifically designed for use as moisture/vapor retarders may also be more puncture resistant. Although the CBC specifies a 6-mil vapor retarder membrane, it is GeoTek's opinion that a minimum 10 mil membrane with joints properly overlapped and sealed should be considered, unless otherwise specified by the slab design professional.

Moisture and vapor retarding systems are intended to provide a certain level of resistance to vapor and moisture transmission through the concrete, but do not eliminate it. The acceptable level of moisture transmission through the slab is to a large extent based on the type of flooring used and environmental conditions. Ultimately, the vapor retarding system should be comprised of suitable elements to limit migration of water and reduce transmission of water vapor through the slab to acceptable levels. The selected elements should have suitable properties (i.e., thickness, composition, strength, and permeability) to achieve the desired performance level.

Moisture retarders can reduce, but not eliminate, moisture vapor rise from the underlying soils up through the slab. Moisture retarder systems should be designed and constructed in

accordance with applicable American Concrete Institute, Portland Cement Association, Post-Tensioning Concrete Institute, ASTM and California Building Code requirements and guidelines.

GeoTek does not practice in the field of moisture vapor transmission evaluation/migration since that practice is not a geotechnical discipline. Therefore, GeoTek recommends that a qualified person, such as the flooring contractor, structural engineer, architect, and/or other experts specializing in moisture control within the building be consulted to evaluate the general and specific moisture and vapor transmission paths and associated potential impact on the proposed construction. That person (or persons) should provide recommendations relative to the slab moisture and vapor retarder systems and for migration of potential adverse impact of moisture vapor transmission on various components of the structures, as deemed appropriate. In addition, the recommendations in this report and GeoTek's services in general are not intended to address mold prevention; since GeoTek, along with geotechnical consultants in general, do not practice in the area of mold prevention. If specific recommendations addressing potential mold issues are desired, then a professional mold prevention consultant should be contacted.

5.3.4 Miscellaneous Foundation Recommendations

- To reduce moisture penetration beneath the slab on grade areas, utility trenches should be backfilled with engineered fill, lean concrete, or concrete slurry where they intercept the perimeter footing or thickened slab edge.
- Spoils from the footing excavations should not be placed in the slab-on-grade areas unless properly moisture-conditioned, compacted and tested. The excavations should be free of loose/sloughed materials and be neatly trimmed at the time of concrete placement.

5.3.5 Foundation Setbacks

Where applicable, the following setbacks should apply to all foundations. Any improvements not conforming to these setbacks may be subject to lateral movements and/or differential settlements:

- The outside bottom edge of all footings should be set back a minimum of $H/3$ (where H is the slope height) from the face of any descending slope. The setback should be at least 7 feet and need not exceed 40 feet.
- The bottom of all footings for structures near retaining walls should be deepened so as to extend below a 1:1 projection upward from the bottom inside edge of the wall

stem. This applies to the existing retaining walls along the perimeter if they are to remain.

- The bottom of any existing foundations for structures should be deepened to extend below a 1:1 projection upward from the bottom of the nearest excavation.

5.3.6 Seismic Design Parameters

The site is located at approximately 33.24404557 degrees west latitude and -117.26580712 degrees north longitude. Site spectral accelerations (S_s and S_1), for 0.2 and 1.0 second periods for a risk targeted two (2) percent probability of exceedance in 50 years (MCER) were determined using the web interface provided by SEAOC/OSHPD (<https://seismicmaps.org>) to access the USGS Seismic Design Parameters. Due to the very apparent density of the underlying sandstone, a Site Class “C” is considered appropriate for this site. The results, based on ASCE 7-16 and the 2019 CBC, are presented in the following table:

SITE SEISMIC PARAMETERS	
Mapped 0.2 sec Period Spectral Acceleration, S_s	0.924g
Mapped 1.0 sec Period Spectral Acceleration, S_1	0.341g
Site Coefficient for Site Class “C”, F_a	1.2
Site Coefficient for Site Class “C”, F_v	1.5
Maximum Considered Earthquake (MCE _R) Spectral Response Acceleration for 0.2 Second, S_{MS}	1.109g
Maximum Considered Earthquake (MCE _R) Spectral Response Acceleration for 1.0 Second, S_{M1}	0.512g
5% Damped Design Spectral Response Acceleration Parameter at 0.2 Second, S_{DS}	0.739g
5% Damped Design Spectral Response Acceleration Parameter at 1 second, S_{D1}	0.341g
Site Modified Peak Ground Acceleration (PGA _M)	0.478g
Seismic Design Category	D

5.3.7 Soil Sulfate Content and Corrosivity

Sulfate content test results indicate water soluble sulfate is less than 0.1 percent by weight, which is considered “S0” as per Table 19.3.1.1 of ACI 318-14. Based upon the test results, no special recommendations for concrete are required for this project due to soil sulfate exposure.

The soil resistivity at this site was tested by others on two samples collected from TP-6 and TP-7 during the field investigation. The results of the testing indicate that the on-site soils are considered “mildly corrosive” and “corrosive” (15,410 and 4,154 ohm-cm for TP-6 and TP-7 respectively) (Roberge, 2000) to buried ferrous metal in accordance with current standards used

by corrosion engineers. It is recommended that a corrosion engineer be consulted to provide recommendations for the protection of buried ferrous metal at this site.

5.3.8 Preliminary Pavement Design

Traffic indices have not been provided during this stage of site planning. In addition, site conditions have not been graded to a final design to evaluate specific pavement subgrade conditions. Therefore, the minimum structural sections based on the City of Oceanside's Engineers Design and Processing Manual's Streets-Design Criteria (Oceanside, 2017) are presented below.

PRELIMINARY ASPHALT PAVEMENT STRUCTURAL SECTION FOR ON-SITE STREETS		
Design Criteria	Asphaltic Concrete (AC) Thickness (inches)	Aggregate Base (AB) Thickness (inches)
Local Street	3.0	6.0
Local Street	4.0	5.0

As noted in the Design and Processing Manual document, actual structural pavement design is to be determined by the geotechnical engineer's testing (R-Value) of the subgrade. Thus, the actual R-Value of the subgrade soils can only be determined at the completion of grading for street subgrades and the above values are subject to change based laboratory testing of the as-graded soils near subgrade elevations.

Asphalt concrete and aggregate base should conform to current Caltrans Standard Specifications Section 39 and 26-1.02, respectively. As an alternative, asphalt concrete can conform to Section 203-6 of the current Standard Specifications for Public Work (Green Book). Crushed aggregate base or crushed miscellaneous base can conform to Section 200-2.2 and 200-2.4 of the Green Book, respectively. Pavement base should be compacted to at least 95 percent of the ASTM D1557 laboratory maximum dry density as determined by ASTM D 1557 test procedures

All pavement installation, including preparation and compaction of subgrade, compaction of base material, placement and rolling of asphaltic concrete, should be done in accordance with the City of Oceanside specifications, and under the observation and testing of GeoTek and a City Inspector where required. Jurisdictional minimum compaction requirements in excess of the aforementioned minimums may govern.

5.3.9 Portland Cement Concrete (PCC)

As an option, Portland Cement concrete (PCC) pavements could also be used at the site for the pavement areas. Based on the traffic loading provided, the following recommended minimum PCC pavement section is provided for these areas:

6 Inches Portland Cement Concrete (PCC) over
6 Inches Aggregate Base (AB) over
12-inches compacted subgrade to 95% per ASTM D 1557

For the PCC options, it is recommended concrete having a minimum 28-day flexural strength of 650 psi be used. A maximum joint spacing of 15 feet is also recommended.

5.4 RETAINING WALL DESIGN AND CONSTRUCTION

5.4.1 General Design Criteria

Preliminary grading plans are not yet available. If retaining walls are added at a later date, the recommendations presented herein may apply to typical masonry or concrete vertical retaining walls to a maximum height of 6 feet. The 2019 CBC only requires the additional earthquake induced lateral force be considered on retaining walls in excess of six (6) feet in height. Therefore, additional review and recommendations should be requested for higher walls.

Retaining wall foundations embedded a minimum of 18 inches into engineered fill or dense formational materials should be designed using an allowable bearing capacity of 2,000 psf. This value may be increased by 300 psf for each additional 12 inches in depth and 300 psf for each additional 12 inches in width to a maximum value of 3,000 psf. An increase of one-third may be applied when considering short-term live loads (e.g., seismic and wind loads). The passive earth pressure may be computed as an equivalent fluid having a density of 350 psf per foot of depth, to a maximum earth pressure of 3,500 psf. A coefficient of friction between soil and concrete of 0.35 may be used with dead load forces. When combining passive pressure and frictional resistance, the passive pressure component should be reduced by one-third.

An equivalent fluid pressure approach may be used to compute the horizontal active pressure against the wall. The appropriate fluid unit weights are given in the table below for specific slope gradients of retained materials utilizing imported select materials.

Surface Slope of Retained Materials (H:V)	Equivalent Fluid Pressure (PCF) Select Backfill*
Level	40
2:1	65

*Select backfill should consist of approved materials with an $EI \leq 20$ and should be provided throughout the active zone.

The above equivalent fluid weights do not include other superimposed loading conditions such as expansive soil, vehicular traffic, structures, seismic conditions or adverse geologic conditions.

5.4.2 Restrained Retaining Walls

Any retaining wall that will be restrained prior to placing backfill or walls that have male or reentrant corners should be designed for at-rest soil conditions using an equivalent fluid pressure of 65 pcf (select backfill), plus any applicable surcharge loading. For areas having male or reentrant corners, the restrained wall design should extend a minimum distance equal to twice the height of the wall laterally from the corner, or as otherwise determined by the structural engineer.

5.4.3 Wall Backfill and Drainage

Wall backfill should include a minimum one (1) foot wide section of $\frac{3}{4}$ to 1-inch clean crushed rock (or approved equivalent). The rock should be placed immediately adjacent to the back of wall and extend up from the backdrain to within approximately 12 inches of finish grade. The upper 12 inches should consist of compacted onsite materials. If the walls are designed using the "select" backfill design parameters, then the "select" materials shall be placed within the active zone as defined by a 1:1 (H:V) projection from the back of the retaining wall footing up to the retained surface behind the wall. Presence of other materials might necessitate revision to the parameters provided and modification of wall designs.

The backfill materials should be placed in lifts no greater than 8-inches in thickness and compacted to a minimum of 90% of the maximum dry density as determined in accordance with ASTM Test Method D 1557. Proper surface drainage needs to be provided and maintained. Water should not be allowed to pond behind retaining walls. Waterproofing of site walls should be performed where moisture migration through the wall is undesirable.

Retaining walls should be provided with an adequate pipe and gravel back drain system to reduce the potential for hydrostatic pressures to develop. A 4-inch diameter perforated collector pipe (Schedule 40 PVC, or approved equivalent) in a minimum of one (1) cubic foot per lineal foot of $\frac{3}{8}$ to one (1) inch clean crushed rock or equivalent, wrapped in filter fabric should be placed

near the bottom of the backfill and be directed (via a solid outlet pipe) to an appropriate disposal area.

As an alternative to the drain, rock and fabric, a pre-manufactured wall drainage product (example: Mira Drain 6000 or approved equivalent) may be used behind the retaining wall. The wall drainage product should extend from the base of the wall to within two (2) feet of the ground surface. The subdrain should be placed in direct contact with the wall drainage product.

Drain outlets should be maintained over the life of the project and should not be obstructed or plugged by adjacent improvements.

6. CONCRETE FLATWORK

6.1 GENERAL CONCRETE FLATWORK

6.1.1 Exterior Concrete Slabs and Sidewalks

Exterior concrete slabs, sidewalks and driveways should be designed using a four-inch minimum thickness. Some shrinkage and cracking of the concrete should be anticipated because of typical mix designs and curing practices typically utilized in construction.

Sidewalks and driveways may be under the jurisdiction of the governing agency. If so, jurisdictional design and construction criteria would apply, if more restrictive than the recommendations presented in this report.

Subgrade soils should be pre-moistened prior to placing concrete. The subgrade soils below exterior slabs, sidewalks, driveways, etc. should be pre-saturated to a minimum of 100 percent (for “very low” expansivity) of the optimum moisture content to a depth of 12 inches.

All concrete installation, including preparation and compaction of subgrade, should be done in accordance with the City of Oceanside specifications, and under the observation and testing of GeoTek, Inc. and a City inspector, if necessary.

6.1.2 Concrete Performance

Concrete cracks should be expected. These cracks can vary from sizes that are essentially unnoticeable to more than 1/8 inch in width. Most cracks in concrete, while unsightly, do not significantly impact long-term performance. While it is possible to take measures (proper

concrete mix, placement, curing, control joints, etc.) to reduce the extent and size of cracks that occur, some cracking will occur despite the best efforts to minimize it. Concrete undergoes chemical processes that are dependent on a wide range of variables, which are difficult, at best, to control. Concrete, while seemingly a stable material, is subject to internal expansion and contraction due to external changes over time.

One of the simplest means to control cracking is to provide weakened control joints for cracking to occur along. These do not prevent cracks from developing; they simply provide a relief point for the stresses that develop. These joints are a widely accepted means to control cracks but are not always effective. Control joints are more effective the more closely spaced they are. GeoTek, Inc. suggests that control joints be placed in two directions and located a distance apart approximately equal to 24 to 36 times the slab thickness.

7. POST CONSTRUCTION CONSIDERATIONS

7.1 LANDSCAPE MAINTENANCE AND PLANTING

Water has been shown to weaken the inherent strength of soil, and slope stability is significantly reduced by overly wet conditions. Positive surface drainage away from graded slopes should be maintained and only the amount of irrigation necessary to sustain plant life should be provided for planted slopes. Controlling surface drainage and runoff and maintaining a suitable vegetation cover can minimize erosion. Plants selected for landscaping should be lightweight, deep-rooted types that require little water and are capable of surviving the prevailing climate.

Overwatering should be avoided. The soils should be maintained in a solid to semi-solid state as defined by the materials Atterberg Limits. Care should be taken when adding soil amendments to avoid excessive watering. Leaching as a method of soil preparation prior to planting is not recommended. An abatement program to control ground-burrowing rodents should be implemented and maintained. This is critical as burrowing rodents can decreased the long-term performance of slopes.

It is common for planting to be placed adjacent to structures in planter or lawn areas. This will result in the introduction of water into the ground adjacent to the foundation. This type of landscaping should be avoided. If used, then extreme care should be exercised with regard to the irrigation and drainage in these areas. Waterproofing of the foundation and/or subdrains may be warranted and advisable. GeoTek could discuss these issues, if desired, when plans are made available.

7.2 DRAINAGE

The need to maintain proper surface drainage and subsurface systems cannot be overly emphasized. Positive site drainage should be maintained at all times. Drainage should not flow uncontrolled down any descending slope. Water should be directed away from foundations and not allowed to pond or seep into the ground adjacent to the footings. Site drainage should conform to Section 1804.4 of the 2019 CBC. Roof gutters and downspouts should discharge onto paved surfaces sloping away from the structure or into a closed pipe system which outfalls to the street gutter pan or directly to the storm drain system. Pad drainage should be directed toward approved areas and not be blocked by other improvements.

7.3 PLAN REVIEW AND CONSTRUCTION OBSERVATIONS

GeoTek recommends that site grading, specifications, retaining wall/shoring plans and foundation plans be reviewed by this office prior to construction to check for conformance with the recommendations of this report. Additional recommendations may be necessary based on these reviews. It is also recommended that GeoTek representatives be present during site grading and foundation construction to check for proper implementation of the geotechnical recommendations. The owner/developer should have GeoTek's representative perform at least the following duties:

- Observe site clearing and grubbing operations for proper removal of unsuitable materials.
- Observe and bottom of removals prior to fill placement.
- Evaluate the suitability of on-site and import materials for fill placement and collect soil samples for laboratory testing when necessary.
- Observe the fill for uniformity during placement, including utility trenches.
- Observe and test the fill for field density and relative compaction.
- Observe and probe foundation excavations to confirm suitability of bearing materials.

If requested, a construction observation and compaction report can be provided by GeoTek, which can comply with the requirements of the governmental agencies having jurisdiction over the project. GeoTek recommends that these agencies be notified prior to commencement of construction so that necessary grading permits can be obtained.

8. LIMITATIONS

The scope of this evaluation is limited to the area explored that is shown on the Geotechnical Map (Figure 2). This evaluation does not and should in no way be construed to encompass any areas beyond the specific area of proposed construction as indicated to us by the client. The scope is based on GeoTek's understanding of the project and the client's needs, GeoTek's proposal (Proposal No. P-0900321-SD) dated October 20th, 2021, and geotechnical engineering standards normally used on similar projects in this region.

The materials observed on the project site appear to be representative of the area; however, soil and bedrock materials vary in character between excavations and natural outcrops, or conditions exposed during site construction. Site conditions may vary due to seasonal changes or other factors. GeoTek, Inc. assumes no responsibility or liability for work, testing or recommendations performed or provided by others.

Since GeoTek's recommendations are based on the site conditions observed and encountered, and laboratory testing, GeoTek's conclusions and recommendations are professional opinions that are limited to the extent of the available data. Observations during construction are important to allow for any change in recommendations found to be warranted. These opinions have been derived in accordance with current standards of practice and no warranty is expressed or implied. Standards of practice are subject to change with time.

9. SELECTED REFERENCES

- American Society of Civil Engineers (ASCE), 2016, "Minimum Design Loads for Buildings and Other Structures," ASCE/SEI 7-16.
- ASTM International (ASTM), "ASTM Volumes 4.08 and 4.09 Soil and Rock."
- Bryant, W.A., and Hart, E.W., 2007, "Fault Rupture Hazard Zones in California, Alquist-Priolo Earthquake Fault Zoning Act with Index to Earthquake Fault Zones Maps," California Geological Survey: Special Publication 42.
- California Code of Regulations, Title 24, 2019 "California Building Code," 2 volumes.
- California Geological Survey (CGS, formerly referred to as the California Division of Mines and Geology), 1977, "Geologic Map of California."
- _____, 1998, "Maps of Known Active Fault Near-Source Zones in California and Adjacent Portions of Nevada," International Conference of Building Officials.
- City of Oceanside, 2016, "City of Oceanside BMP Design Manual"
- City of Oceanside, 2017, "Engineers Design and Processing Manual," Chapter 2, Section 3.8.
- GeoTek, Inc., In-house proprietary information.
- Kennedy, M.P., and Tan, S.S., 2007, "Geologic Map of the Oceanside 30x60-minute Quadrangle, California," California Geological Survey, Regional Geologic Map No. 2, map scale 1:100,000.
- Pasco Laret Suiter and Associates, 2022, "Preliminary Lot Layout, Guajome Lake Road," PLSA 3775, one sheet, dated March 17, 2022.
- Structural Engineers Association of California/California Office of Statewide Health Planning and Development (SEOC/OSHPD), 2019, Seismic Design Maps web interface, <https://seismicmaps.org>
- Terzaghi, K. and Peck, R., 1967, "Soil Mechanics in Engineering Practice", second edition.
- University of California Davis, 1997, Soil Web Interactive Map, [SoilWeb: An Online Soil Survey Browser | California Soil Resource Lab \(ucdavis.edu\)](#), accessed May 5, 2022

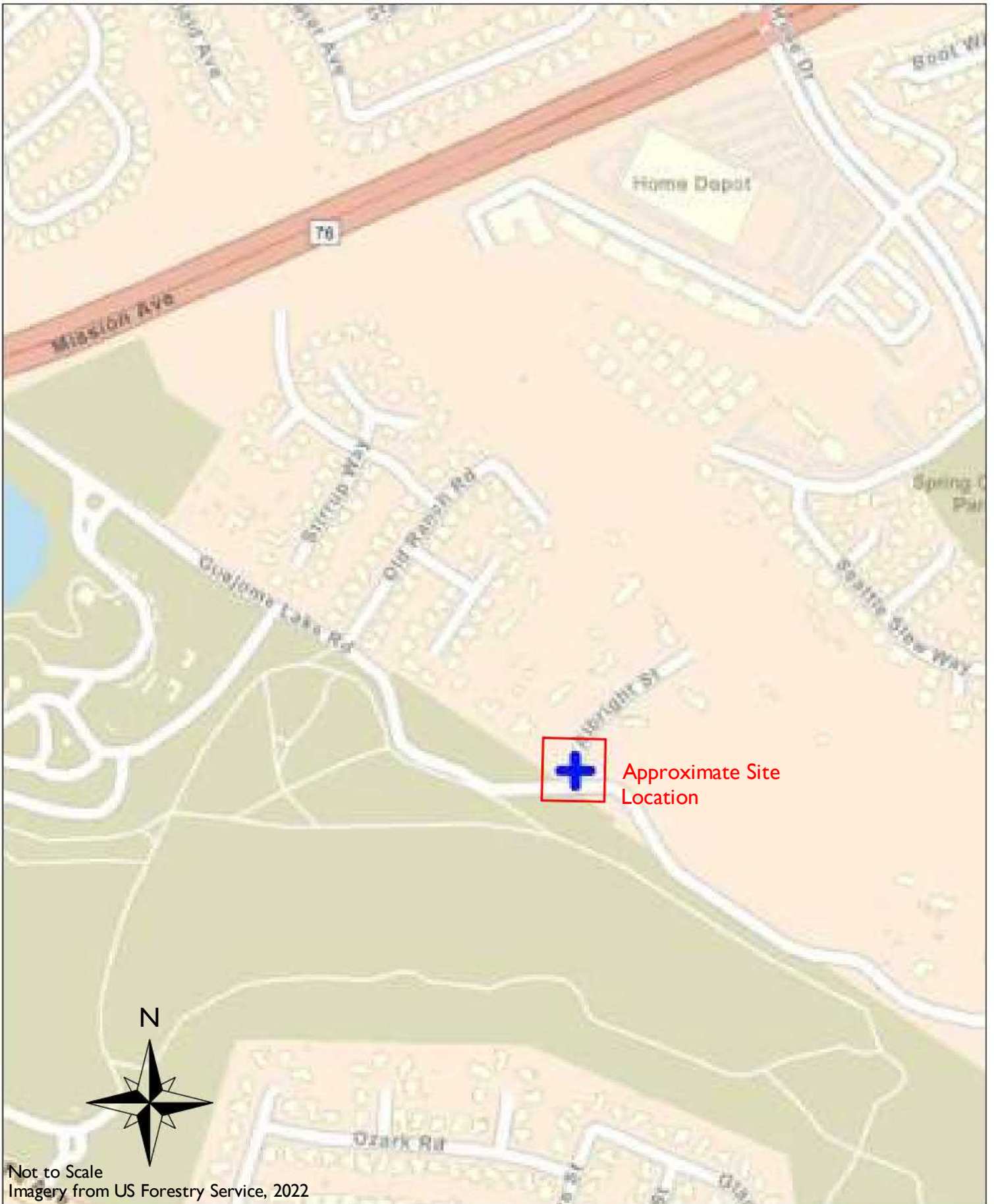

Not to Scale
Imagery from US Forestry Service, 2022







Rincon Homes
 APN 157-412-15
 NE of Albright St & Guajome Lake Rd
 Oceanside, California

PN: 3775-SD DATE: April 2022

Figure 1
 Site Location

GEOTEK
 1384 Poinsettia Avenue, Suite A
 Vista, California 92081

LEGEND

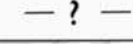
-  P-3 Approximate Location of Percolation Test
-  T-9 Approximate Location and Orientation of Test Pit
-  Approximate Limits of Study, this report
-  Qcol Colluvium
-  Qal Alluvium
-  Tsa Santiago Formation, Circled where Buried
-  Geologic Contact

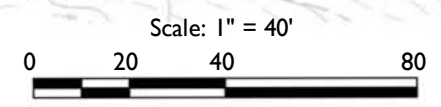
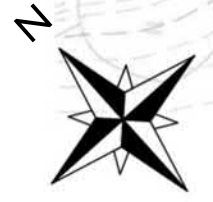
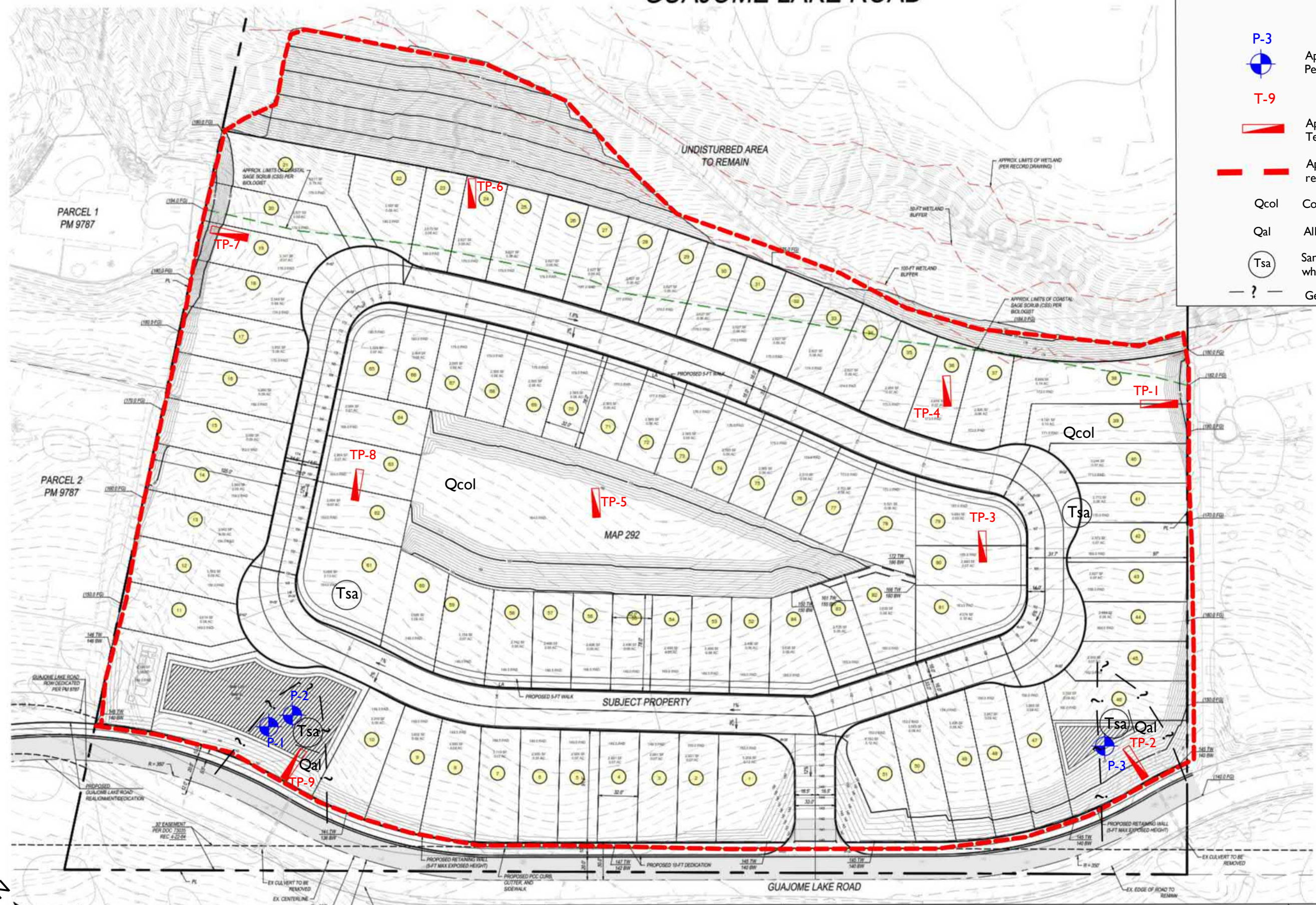

Rincon Homes
 APN 157-412-15
 NE of Albright St & Guajome Lake Rd
 Oceanside, California

PN: 3775-SD DATE: April 2022

Figure 2
 Geotechnical Map



1384 Poinsettia Avenue, Suite A
 Vista, California 92081

Plan adapted from "Preliminary Lot Layout" by Pasco Laret Suiter

APPENDIX A

LOGS OF EXPLORATION AND INFILTRATION WORKSHEETS

A - FIELD TESTING AND SAMPLING PROCEDURES

Bulk Samples (Large)

These samples are normally large bags of earth materials over 20 pounds in weight collected from the field by means of hand digging or exploratory cuttings.

B – BORING/TRENCH LOG LEGEND

The following abbreviations and symbols often appear in the classification and description of soil and rock on the logs of borings/trenches:

SOILS

USCS Unified Soil Classification System

f-c Fine to coarse

f-m Fine to medium

GEOLOGIC

B: Attitudes Bedding: strike/dip

J: Attitudes Joint: strike/dip

C: Contact line

..... Dashed line denotes USCS material change

———— Solid Line denotes unit / formational change

———— Thick solid line denotes end of boring/trench

(Additional denotations and symbols are provided on the log of borings/trenches)

GeoTek, Inc.

LOG OF EXPLORATORY TRENCH

CLIENT:	Rincon Homes	DRILLER:	Luna Construction	LOGGED BY:	MRF
PROJECT NAME:	Guajome Crest	DRILL METHOD:	Test Pit	OPERATOR:	Sal
PROJECT NO.:	3775-SD	HAMMER:	-	RIG TYPE:	CAT 305.5E (mini) excavator
LOCATION:	Oceanside, CA	ELEVATION:	176 ft	DATE:	3/29/2022

Depth (ft)	SAMPLES			USCS Symbol	TEST PIT NO.: TP-1 MATERIAL DESCRIPTION AND COMMENTS	Laboratory Testing		
	Sample Type	Blows/ 6 in	Sample Number			Water Content (%)	Dry Density (pcf)	Others
0				SM	Colluvium (Qcol) Silty fine to medium SAND, brown, loose, damp, roots			
5	X		BB-1		Santiago Formation (Tsa) Fine to coarse SANDSTONE, yellow to light tan with orange oxidation, dry, subangular grains with some fine gravels, quartz rich Fine to coarse SANDSTONE begins turning more yellow with more frequent gravels and quartz, operator struggles to excavate, bucket has new teeth			AL,SA
10					HOLE TERMINATED AT 8 FEET No groundwater encountered Backfilled with soil cuttings			
15								
20								
25								
30								

LEGEND	Sample type:	---Ring	---SPT	---Small Bulk	---Large Bulk	---Water Table		
	Lab testing:	AL = Atterberg Limits	SR = Sulfate/Resisitivity Test	EI = Expansion Index	SH = Shear Test	SA = Sieve Anal	RV = R-Value Test	CO = Consolida

GeoTek, Inc.
LOG OF EXPLORATORY TRENCH

CLIENT:	Rincon Homes	DRILLER:	Luna Construction	LOGGED BY:	MRF
PROJECT NAME:	Guajome Crest	DRILL METHOD:	Test Pit	OPERATOR:	Sal
PROJECT NO.:	3775-SD	HAMMER:	-	RIG TYPE:	CAT 305.5E (mini) excavator
LOCATION:	Oceanside, CA	ELEVATION:	143 ft	DATE:	3/29/2022

Depth (ft)	SAMPLES			USCS Symbol	TEST PIT NO.: TP-2 MATERIAL DESCRIPTION AND COMMENTS	Laboratory Testing		
	Sample Type	Blows/ 6 in	Sample Number			Water Content (%)	Dry Density (pcf)	Others
5				SM	<u>Alluvium (Qal)</u> Silty fine to medium SAND, light brown to brown, damp, roots Silty fine to medium SAND, light brown, dry, roots <u>Santiago Formation (Tsa)</u> Fine to coarse SANDSTONE, light yellow to white, scattered gray sandstones, dry, assorted fine gravels and quartz Density increasing with depth			
10					HOLE TERMINATED AT 6.5 FEET No groundwater encountered Backfilled with soil cuttings			
15								
20								
25								
30								

LEGEND	Sample type:	<input type="checkbox"/> ---Ring	<input type="checkbox"/> ---SPT	<input type="checkbox"/> ---Small Bulk	<input type="checkbox"/> ---Large Bulk	<input type="checkbox"/> ---Water Table
	Lab testing:	AL = Atterberg Limits	El = Expansion Index	SA = Sieve Anal	RV = R-Value Test	
	SR = Sulfate/Resisitvity Test	SH = Shear Test	CO = Consolida	MD = Maximum Density		

GeoTek, Inc.
LOG OF EXPLORATORY TRENCH

CLIENT: Rincon Homes	DRILLER: Luna Construction	LOGGED BY: MRF
PROJECT NAME: Guajome Crest	DRILL METHOD: Test Pit	OPERATOR: Sal
PROJECT NO.: 3775-SD	HAMMER: -	RIG TYPE: CAT 305.5E (mini) excavator
LOCATION: Oceanside, CA	ELEVATION: 166 ft	DATE: 3/29/2022

Depth (ft)	SAMPLES			USCS Symbol	TEST PIT NO.: TP-3 MATERIAL DESCRIPTION AND COMMENTS	Laboratory Testing		
	Sample Type	Blows/ 6 in	Sample Number			Water Content (%)	Dry Density (pcf)	Others
5				SM	<p>Colluvium (Qcol) Silty fine to medium SAND, light brown to brown, moist, roots</p> <p>Santiago Formation (Tsa) Fine to coarse SANDSTONE, light yellow to white with orange oxidation with interspersed gray siltstones, dry, gravels and quartz rich</p>			
10					<p>HOLE TERMINATED AT 8 FEET</p> <p>No groundwater encountered Backfilled with soil cuttings</p>			
15								
20								
25								
30								

LEGEND	Sample type:	---Ring	---SPT	---Small Bulk	---Large Bulk	---Water Table
	Lab testing:	AL = Atterberg Limits	El = Expansion Index	SA = Sieve Anal	RV = R-Value Test	
	SR = Sulfate/Resisitvity Test	SH = Shear Test	CO = Consolida	MD = Maximum Density		

GeoTek, Inc.
LOG OF EXPLORATORY TRENCH

CLIENT: Rincon Homes	DRILLER: Luna Construction	LOGGED BY: MRF
PROJECT NAME: Guajome Crest	DRILL METHOD: Test Pit	OPERATOR: Sal
PROJECT NO.: 3775-SD	HAMMER: -	RIG TYPE: CAT 305.5E (mini) excavator
LOCATION: Oceanside, CA	ELEVATION: 160 ft	DATE: 3/29/2022

Depth (ft)	SAMPLES			USCS Symbol	TEST PIT NO.: TP-4 MATERIAL DESCRIPTION AND COMMENTS	Laboratory Testing		
	Sample Type	Blows/ 6 in	Sample Number			Water Content (%)	Dry Density (pcf)	Others
5				SM	Colluvium (Qcol) Silty fine to medium SAND, brown to light brown, damp, roots			
5				SW	Tertiary Santiago Formation (Tsa) Fine to coarse SANDSTONE, light yellow to orange, dry, angular grains, evidence of fluvial paleochannel and rip-up clasts from 1 foot to 3 feet tall thaleg incised channel embankment SANDSTONE continues, gray and brown siltstones scattered throughout			
10					HOLE TERMINATED AT 8 FEET No groundwater encountered Backfilled with soil cuttings			
15								
20								
25								
30								

LEGEND	Sample type:	<input type="checkbox"/> ---Ring	<input type="checkbox"/> ---SPT	<input type="checkbox"/> ---Small Bulk	<input type="checkbox"/> ---Large Bulk	<input type="checkbox"/> ---Water Table
	Lab testing:	AL = Atterberg Limits	El = Expansion Index	SA = Sieve Anal	RV = R-Value Test	
	SR = Sulfate/Resisitvity Test	SH = Shear Test	CO = Consolida	MD = Maximum Density		

GeoTek, Inc.
LOG OF EXPLORATORY TRENCH

CLIENT:	Rincon Homes	DRILLER:	Luna Construction	LOGGED BY:	MRF
PROJECT NAME:	Guajome Crest	DRILL METHOD:	Test Pit	OPERATOR:	Sal
PROJECT NO.:	3775-SD	HAMMER:	-	RIG TYPE:	CAT 305.5E (mini) excavator
LOCATION:	Oceanside, CA	ELEVATION:	173 ft	DATE:	3/29/2022

Depth (ft)	SAMPLES			USCS Symbol	TEST PIT NO.: TP-5 MATERIAL DESCRIPTION AND COMMENTS	Laboratory Testing		
	Sample Type	Blows/ 6 in	Sample Number			Water Content (%)	Dry Density (pcf)	Others
5				SM	Colluvium (Qcol) Silty fine to medium SAND, light brown to brown, damp at 6 inches, dry below, roots Tertiary Santiago Formation (Tsa) Fine to coarse SANDSTONE, light yellow to white, dry, brown siltstone SANDSTONE with gravels, quartes rich			
10					HOLE TERMINATED AT 8 FEET No groundwater encountered Backfilled with soil cuttings			
15								
20								
25								
30								

LEGEND	Sample type:	<input type="checkbox"/> ---Ring	<input type="checkbox"/> ---SPT	<input type="checkbox"/> ---Small Bulk	<input type="checkbox"/> ---Large Bulk	<input type="checkbox"/> ---Water Table
	Lab testing:	AL = Atterberg Limits	El = Expansion Index	SA = Sieve Anal	RV = R-Value Test	
	SR = Sulfate/Resisitvity Test	SH = Shear Test	CO = Consolida	MD = Maximum Density		

GeoTek, Inc.
LOG OF EXPLORATORY TRENCH

CLIENT:	Rincon Homes	DRILLER:	Luna Construction	LOGGED BY:	MRF
PROJECT NAME:	Guajome Crest	DRILL METHOD:	Test Pit	OPERATOR:	Sal
PROJECT NO.:	3775-SD	HAMMER:	-	RIG TYPE:	CAT 305.5E (mini) excavator
LOCATION:	Oceanside, CA	ELEVATION:	181 ft	DATE:	3/29/2022

Depth (ft)	SAMPLES			USCS Symbol	TEST PIT NO.: TP-6 MATERIAL DESCRIPTION AND COMMENTS	Laboratory Testing		
	Sample Type	Blows/ 6 in	Sample Number			Water Content (%)	Dry Density (pcf)	Others
0				SM	Colluvium (Qcol) Silty fine to medium SAND, brown to dark brown, moist at 6 inches, damp below, roots			
5	X		BB-1		Santiago Formation (Tsa) Fine to coarse SANDSTONE, white to light yellow, damp, small amounts of quartz Fine to coarse SANDSTONE, damp, micaceous, interspersed with gray siltstones.			AL,SA,SR
10					HOLE TERMINATED AT 7 FEET No groundwater encountered Backfilled with soil cuttings			
15								
20								
25								
30								

LEGEND	Sample type:	<input type="checkbox"/> ---Ring	<input type="checkbox"/> ---SPT	<input type="checkbox"/> ---Small Bulk	<input checked="" type="checkbox"/> ---Large Bulk	<input type="checkbox"/> ---Water Table
	Lab testing:	AL = Atterberg Limits	El = Expansion Index	SA = Sieve Anal	RV = R-Value Test	
	SR = Sulfate/Resisitivity Test	SH = Shear Test	CO = Consolida	MD = Maximum Density		

GeoTek, Inc.
LOG OF EXPLORATORY TRENCH

CLIENT:	Rincon Homes	DRILLER:	Luna Construction	LOGGED BY:	MRF
PROJECT NAME:	Guajome Crest	DRILL METHOD:	Test Pit	OPERATOR:	Sal
PROJECT NO.:	3775-SD	HAMMER:	-	RIG TYPE:	CAT 305.5E (mini) excavator
LOCATION:	Oceanside, CA	ELEVATION:	179 ft	DATE:	3/29/2022

Depth (ft)	SAMPLES			USCS Symbol	TEST PIT NO.: TP-7 MATERIAL DESCRIPTION AND COMMENTS	Laboratory Testing		
	Sample Type	Blows/ 6 in	Sample Number			Water Content (%)	Dry Density (pcf)	Others
5	X		BB-1	SM	<p>Colluvium (Qcol) Silty fine to medium SAND, dark brown, moist, roots</p> <p>Tertiary Santiago Formation (Tsa) Fine to coarse SANDSTONE, white to light gray, damp, micaceous Interspersed orange SANDSTONE to total depth Fine to coarse SANDSTONE, white, scattered orange sandstone with some gray siltstone along rest of test pit, subrounded</p>			MD,EI,DS,SR
10					<p>HOLE TERMINATED AT 7.5 FEET</p> <p>No groundwater encountered Backfilled with soil cuttings</p>			
15								
20								
25								
30								

LEGEND	Sample type:	---Ring	---SPT	---Small Bulk	---Large Bulk	---Water Table
	Lab testing:	AL = Atterberg Limits	EI = Expansion Index	SA = Sieve Anal	RV = R-Value Test	
	SR = Sulfate/Resisitvity Test	SH = Shear Test	CO = Consolida	MD = Maximum Density		

GeoTek, Inc.
LOG OF EXPLORATORY TRENCH

CLIENT:	Rincon Homes	DRILLER:	Luna Construction	LOGGED BY:	MRF
PROJECT NAME:	Guajome Crest	DRILL METHOD:	Test Pit	OPERATOR:	Sal
PROJECT NO.:	3775-SD	HAMMER:	-	RIG TYPE:	CAT 305.5E (mini) excavator
LOCATION:	Oceanside, CA	ELEVATION:	168 ft	DATE:	3/29/2022

Depth (ft)	SAMPLES			USCS Symbol	TEST PIT NO.: TP-8 MATERIAL DESCRIPTION AND COMMENTS	Laboratory Testing		
	Sample Type	Blows/ 6 in	Sample Number			Water Content (%)	Dry Density (pcf)	Others
5				SM	<p>Colluvium (Qcol) Silty fine to medium SAND, brown, damp, loose, some roots</p> <p>Santiago Formation (Tsa) Medium to coarse SANDSTONE, light brown to brown, damp, medium dense, interspersed gray cobbles and quartz</p> <p>Fine to coarse SANDSTONE, light yellow to light tan, dry, interspersed siltstones and quartz density increasing with depth</p>			
10					<p>HOLE TERMINATED AT 7.5 FEET</p> <p>No groundwater encountered Backfilled with soil cuttings</p>			
15								
20								
25								
30								

LEGEND	Sample type:	<input type="checkbox"/> ---Ring	<input type="checkbox"/> ---SPT	<input type="checkbox"/> ---Small Bulk	<input type="checkbox"/> ---Large Bulk	<input type="checkbox"/> ---Water Table
	Lab testing:	AL = Atterberg Limits	El = Expansion Index	SA = Sieve Anal	RV = R-Value Test	
	SR = Sulfate/Resisitvity Test	SH = Shear Test	CO = Consolida	MD = Maximum Density		

GeoTek, Inc.
LOG OF EXPLORATORY TRENCH

CLIENT:	Rincon Homes	DRILLER:	Luna Construction	LOGGED BY:	MRF
PROJECT NAME:	Guajome Crest	DRILL METHOD:	Test Pit	OPERATOR:	Sal
PROJECT NO.:	3775-SD	HAMMER:	-	RIG TYPE:	CAT 305.5E (mini) excavator
LOCATION:	Oceanside, CA	ELEVATION:	149 ft	DATE:	3/29/2022

Depth (ft)	SAMPLES			USCS Symbol	TEST PIT NO.: TP-9 MATERIAL DESCRIPTION AND COMMENTS	Laboratory Testing		
	Sample Type	Blows/ 6 in	Sample Number			Water Content (%)	Dry Density (pcf)	Others
0				SM	Alluvium (Qal) Silty fine to medium SAND, brown to dark brown, moist until 6 inches, loose, some roots			
5					Santiago Formation (Tsa) Fine to coarse SANDSTONE, orange to red contact, dipping NE Fine to coarse SANDSTONE, light yellow to light tan, damp, medium dense, scattered orange sandstone, small amounts of quartz and gravels, interspersed gray siltstone Density increasing with depth			
10					HOLE TERMINATED AT 7.5 FEET No groundwater encountered Backfilled with soil cuttings			
15								
20								
25								
30								

LEGEND	Sample type:	<input type="checkbox"/> ---Ring	<input type="checkbox"/> ---SPT	<input type="checkbox"/> ---Small Bulk	<input type="checkbox"/> ---Large Bulk	<input type="checkbox"/> ---Water Table
	Lab testing:	AL = Atterberg Limits	El = Expansion Index	SA = Sieve Anal	RV = R-Value Test	
	SR = Sulfate/Resisitvity Test	SH = Shear Test	CO = Consolida	MD = Maximum Density		

Client: Rincon
Project: Guajome Crest
Project No: 3775-SD
Date: 4/4/2022

Boring No. P-1

Infiltration Rate (Porchet Method)

Time Interval, $\Delta t =$ 30
 Final Depth to Water, $D_F =$ 19.00
 Test Hole Radius, $r =$ 3.00
 Initial Depth to Water, $D_O =$ 18
 Total Test Hole Depth, $D_T =$ 55

Equation - $I_t = \frac{\Delta H (60r)}{\Delta t (r+2H_{avg})}$

$H_O = D_T - D_O =$ 37.00
 $H_F = D_T - D_F =$ 36.00
 $\Delta H = \Delta D = H_O - H_F =$ 1.00
 $H_{avg} = (H_O + H_F) / 2 =$ 36.50

$I_t =$ 0.08 Inches per Hour



Client: Rincon
Project: Guajome Crest
Project No: 3775-SD
Date: 4/4/2022

Boring No. P-2

Infiltration Rate (Porchet Method)

Time Interval, $\Delta t =$ 30
 Final Depth to Water, $D_F =$ 26.00
 Test Hole Radius, $r =$ 3.00
 Initial Depth to Water, $D_O =$ 18
 Total Test Hole Depth, $D_T =$ 50.5

Equation - $I_t = \frac{\Delta H (60r)}{\Delta t (r+2H_{avg})}$

$H_O = D_T - D_O =$ 32.50
 $H_F = D_T - D_F =$ 24.50
 $\Delta H = \Delta D = H_O - H_F =$ 8.00
 $H_{avg} = (H_O + H_F) / 2 =$ 28.50

$I_t =$ 0.80 Inches per Hour



Client: Rincon
Project: Guajome Crest
Project No: 3775-SD
Date: 4/4/2022

Boring No. P-3

Infiltration Rate (Porchet Method)

Time Interval, $\Delta t =$ 30
 Final Depth to Water, $D_F =$ 23.00
 Test Hole Radius, $r =$ 3.00
 Initial Depth to Water, $D_O =$ 18
 Total Test Hole Depth, $D_T =$ 52

Equation - $I_t = \frac{\Delta H (60r)}{\Delta t (r+2H_{avg})}$

$H_O = D_T - D_O =$ 34.00
 $H_F = D_T - D_F =$ 29.00
 $\Delta H = \Delta D = H_O - H_F =$ 5.00
 $H_{avg} = (H_O + H_F) / 2 =$ 31.50

$I_t =$ 0.45 Inches per Hour



Appendix D: Approved Infiltration Rate Assessment Methods

Infiltration Restrictions		Form 4	
Retention is required at the project site to the maximum extent practicable. Complete this form to summarize applicable infiltration restrictions. Supporting documentation must be provided in the Attachments.			
Restriction Element		Applicable?	
Mandatory Considerations	BMP is within 100 feet of contaminated soils	<input type="checkbox"/> Yes	<input checked="" type="checkbox"/> No
	BMP is within 100 feet of industrial activities lacking source control	<input type="checkbox"/> Yes	<input checked="" type="checkbox"/> No
	BMP is within 100 feet of well/groundwater basin	<input type="checkbox"/> Yes	<input checked="" type="checkbox"/> No
	BMP is within 50 feet of septic tanks/leach fields	<input type="checkbox"/> Yes	<input checked="" type="checkbox"/> No
	BMP is within 10 feet of structures/tanks/walls	<input type="checkbox"/> Yes	<input checked="" type="checkbox"/> No
	BMP is within 10 feet of sewer utilities	<input type="checkbox"/> Yes	<input checked="" type="checkbox"/> No
	BMP is within 10 feet of groundwater table	<input type="checkbox"/> Yes	<input checked="" type="checkbox"/> No
	BMP is within hydric soils	<input type="checkbox"/> Yes	<input checked="" type="checkbox"/> No
	BMP is within highly liquefiable soils and has connectivity to structures	<input type="checkbox"/> Yes	<input checked="" type="checkbox"/> No
	BMP is within 1.5 times the height of adjacent steep slopes ($\geq 25\%$)	<input checked="" type="checkbox"/> Yes	<input type="checkbox"/> No
	City staff has assigned "Restricted" Infiltration Category	<input type="checkbox"/> Yes	<input checked="" type="checkbox"/> No
Optional Considerations	BMP is within predominantly Type D soil	<input type="checkbox"/> Yes	<input type="checkbox"/> No
	BMP is within 10 feet of property line	<input type="checkbox"/> Yes	<input type="checkbox"/> No
	BMP is within fill depths of ≥ 5 feet (existing or proposed)	<input checked="" type="checkbox"/> Yes	<input type="checkbox"/> No
	BMP is within 10 feet of underground utilities	<input type="checkbox"/> Yes	<input type="checkbox"/> No
	BMP is within 250 feet of ephemeral stream	<input type="checkbox"/> Yes	<input type="checkbox"/> No
	Other (provide detailed geotechnical support in Attachment 6)	<input type="checkbox"/> Yes	<input type="checkbox"/> No
Result	Unrestricted – No restriction elements are applicable	<input type="checkbox"/>	
	Restricted – One or more restriction elements are applicable	<input checked="" type="checkbox"/>	

Appendix D: Approved Infiltration Rate Assessment Methods

Table D.2-4: Factor of Safety and Design Infiltration Rate Worksheet

Factor of Safety and Design Infiltration Rate Worksheet		Worksheet D.5-1			
Factor Category		Factor Description	Assigned Weight (w)	Factor Value (v)	Product (p) $p = w \times v$
A	Suitability Assessment	Soil assessment methods	0.25	Refer to Table D.2-5	0.5
		Predominant soil texture	0.25		0.25
		Site soil variability	0.25		0.5
		Depth to groundwater / impervious layer	0.25		0.25
		Suitability Assessment Safety Factor, $S_A = \Sigma p$			
B	Design	Level of pretreatment/ expected sediment loads	0.5	Refer to Table D.2-5	To be completed by BMP Designer
		Redundancy/resiliency	0.25		
		Compaction during construction	0.25		
		Design Safety Factor, $S_B = \Sigma p$			
Safety Factor, $S_{total} = S_A \times S_B$					

D.2 Determination of Design Infiltration Rates

This section is only applicable if the determination of design infiltration rates is performed by a licensed engineer practicing in geotechnical engineering. The guidance in this section identifies methods for identifying observed infiltration rates, corrected infiltration rates, safety factors, and design infiltration rates for use in structural BMP design. Upon completion of this section, the Geotechnical Engineer must recommend a design infiltration rate for each DMA and provide adequate support/discussion in the geotechnical report.

Table D.2-1: Elements for Determination of Design Infiltration Rates

Parameter	Value	Unit
Initial Infiltration Rate (Section D.2.1)	0.44	in/hr
Corrected Infiltration Rate (Section D.2.2)	0.44	in/hr
Safety Factor (Section D.2.3)	1.5	unitless
Design Infiltration Rate (Corrected Infiltration rate/Safety Factor)	0.29	in/hr

Does not include safety factor from Table D.2-4 section B, which should be completed by the BMP designer.

D.2.1 Initial Infiltration Rate

For purposes of this manual, the initial infiltration rate is the infiltration rate that has been identified based on the initial testing methods. Some of the acceptable methods for determining initial infiltration rates are presented in Table D.2-2 below, though other testing methods may be acceptable as evaluated by the geotechnical engineer. The geotechnical engineer should use professional discretion when selecting a testing method as it may ultimately impact the types of BMPs that are permitted.

Table D.2-2: Comparison of Infiltration Rate Estimation and Testing Methods

Test	Suitability at Planning Level Screening Phase	Suitability at BMP Design Phase
NRCS Soil Survey Maps	Yes, but mapped soil types must be confirmed with site observations. Regional soil maps are known to contain inaccuracies at the scale of typical development sites.	No, unless a strong correlation is developed between soil types and infiltration rates in the direct vicinity of the site and an elevated factor of safety is used.
Grain Size Analysis	Not preferred. Should only be used if a strong correlation has been developed between grain size analysis and measured infiltration rates testing results of site soils.	No

APPENDIX B

RESULTS OF LABORATORY TESTING

SUMMARY OF LABORATORY TESTING

Identification and Classification

Soils were identified visually in general accordance with the standard practice for description and identification of soils (ASTM D 2488). The soil identifications and classifications are shown on the Logs of Exploration in Appendix A.

Moisture Density Modified Proctor

Laboratory testing was performed on one sample collected during the subsurface exploration for compaction characteristics. The laboratory maximum dry density and optimum moisture content for the soil was determined in general accordance with ASTM Test Method D 1557 procedures. The test results are graphically presented in Appendix B.

Expansion Index Test

Expansion Index testing was performed on one sample collected during the subsurface exploration from test pit TP-7. The expansion index was determined in general accordance with ASTM Test Method D 4829 procedures. The test results are presented in Appendix B.

Full Corrosion Suite

A full corrosion series was performed in general accordance with several ASTM Test Methods on two representative samples collected during the subsurface exploration. The samples were obtained from Test Pit TP-6 and TP-7 and tested by Project X Engineering.

Atterberg Limits

Atterberg limits testing were performed on two (2) sandy samples collected from the site. The tests were performed in general accordance with ASTM D 4318. The test results are presented in Appendix B.

Percent of Soil Passing No 200 Sieve

The amount of soil finer than No. 200 sieve was determined for two sandy samples collected from the site. The tests were performed in general accordance with ASTM D 1140. The test results are presented in Appendix B.

Direct Shear

Shear testing was performed in a direct shear machine of the strain-control type in general accordance with ASTM Test Method D 3080 procedures. The rate of deformation is approximately 0.025 inches per minute. The samples were sheared under varying confining loads to determine the coulomb shear strength parameters, angle of internal friction and cohesion. One test was performed on a bulk sample that was remolded to approximately 90 percent of the maximum dry density as determined by ASTM D 1557. The results of the testing are graphically presented in Appendix B.



-200 WASH

Date: 4/4/2022
W.O.: 3775-SD sample ID TP-1 BB-1
Client: Rincon Homes depth 3-5 ft
Project: Guajome Crest

Sieve Size	Particle Diameter		Wt. Retained	Wt. Passing	% Passing	Specs
	in.	mm.				
#200	0.0029	0.074	177.2	10.9	5.8%	
Dry Weight	<u>188.1</u>					
Soak Time	<u>10</u> Minutes					



-200 WASH

Date: 4/4/2022
W.O.: 3775-SD sample ID TP-6 BB-1
Client: Rincon Homes depth 3-5 ft
Project: Guajome Crest

Sieve Size	Particle Diameter		Wt. Retained	Wt. Passing	% Passing	Specs
	in.	mm.				
#200	0.0029	0.074	192.1	26.8	12.2%	
Dry Weight	<u>218.9</u>					
Soak Time	<u>10</u> Minutes					



EXPANSION INDEX TEST

(ASTM D4829)

Project Name: Guajome Crest
Project Number: 3775-SD
Project Location: Oceanside, CA

Tested/ Checked By: CH Lab No 3942
Date Tested: 4/4/2022
Sample Source: TP-7 BB-1
Sample Description: White Gray Fine Sand w/ Silt

Ring Id: 12 Ring Dia. " 4" Ring l. 1"
 Loading weight: 5516. grams

DENSITY DETERMINATION

A	Weight of compacted sample & ring	773.1
B	Weight of ring	371
C	Net weight of sample	402.1
D	Wet Density, lb / ft ³ (C*0.3016)	121.3
E	Dry Density, lb / ft ³ (D/1.F)	107.5

SATURATION DETERMINATION

	Wet Weight of sample & tare	207.8
	Dry Weight of sample & tare	184.8
	Tare	4.8
F	Initial Moisture Content, %	12.8
G	(E*F)	1374.0
H	(E/167.232)	0.64
I	(1.-H)	0.36
J	(62.4*I)	22.3
K	(G/J)= L % Saturation	61.7

READINGS		
DATE	TIME	READING
4/4/2022	10:00	164
4/4/2022	10:10	161
4/4/2022	10:11	161
4/4/2022	10:16	161
4/4/2022	13:16	161
4/4/2022	13:26	161

Initial
 10 min/Dry
 1 min/Wet
 5 min/Wet
 Random
 Final

FINAL MOISTURE			
Weight of wet sample & tare	Wt. of dry sample & tare	Tare	% Moisture
130.7	109.3	4.8	20.5%

EXPANSION INDEX = 2



MOISTURE/DENSITY RELATIONSHIP

Client: Rincon Homes
Project: Guajome Crest
Location: Oceanside, CA
Material Type: White Gray Fine Sand w/Silt
Material Supplier: -
Material Source: -
Sample Location: TP-7 BB-1
 -
Sampled By: MRF
Received By: MRF
Tested By: CH
Reviewed By: -

Job No.: 3775-SD
Lab No.: 3942

Date Sampled: 3/29/2022
Date Received: 3/29/2022
Date Tested: 4/4/2022
Date Reviewed: -

Test Procedure: ASTM D1557 **Method:** A
Oversized Material (%): 0.0 **Correction Required:** yes no

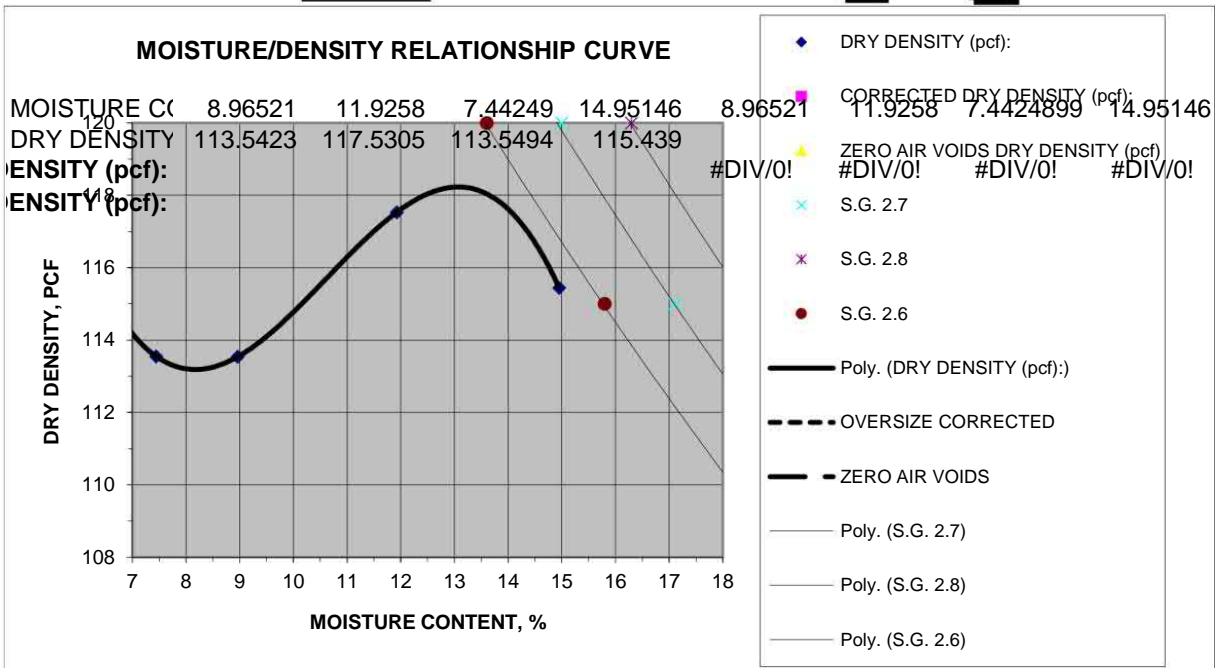

MOISTURE DENSITY RELATIONSHIP VALUES

Maximum Dry Density, pcf @ **Optimum Moisture, %**
Corrected Maximum Dry Density, pcf @ **Optimum Moisture, %**

MATERIAL DESCRIPTION

Grain Size Distribution:

	% Gravel (retained on No. 4)
	% Sand (Passing No. 4, Retained on No. 200)
	% Silt and Clay (Passing No. 200)

Classification:

Unified Soils Classification: _____
 AASHTO Soils Classification: _____

Atterberg Limits:

	Liquid Limit, %
	Plastic Limit, %
	Plasticity Index, %



DIRECT SHEAR TEST

Project Name: Guajome Crest
Project Number: 3775-SD

Sample Location: TP-7 @ 2-4 feet
Date Tested: 4/22/2022

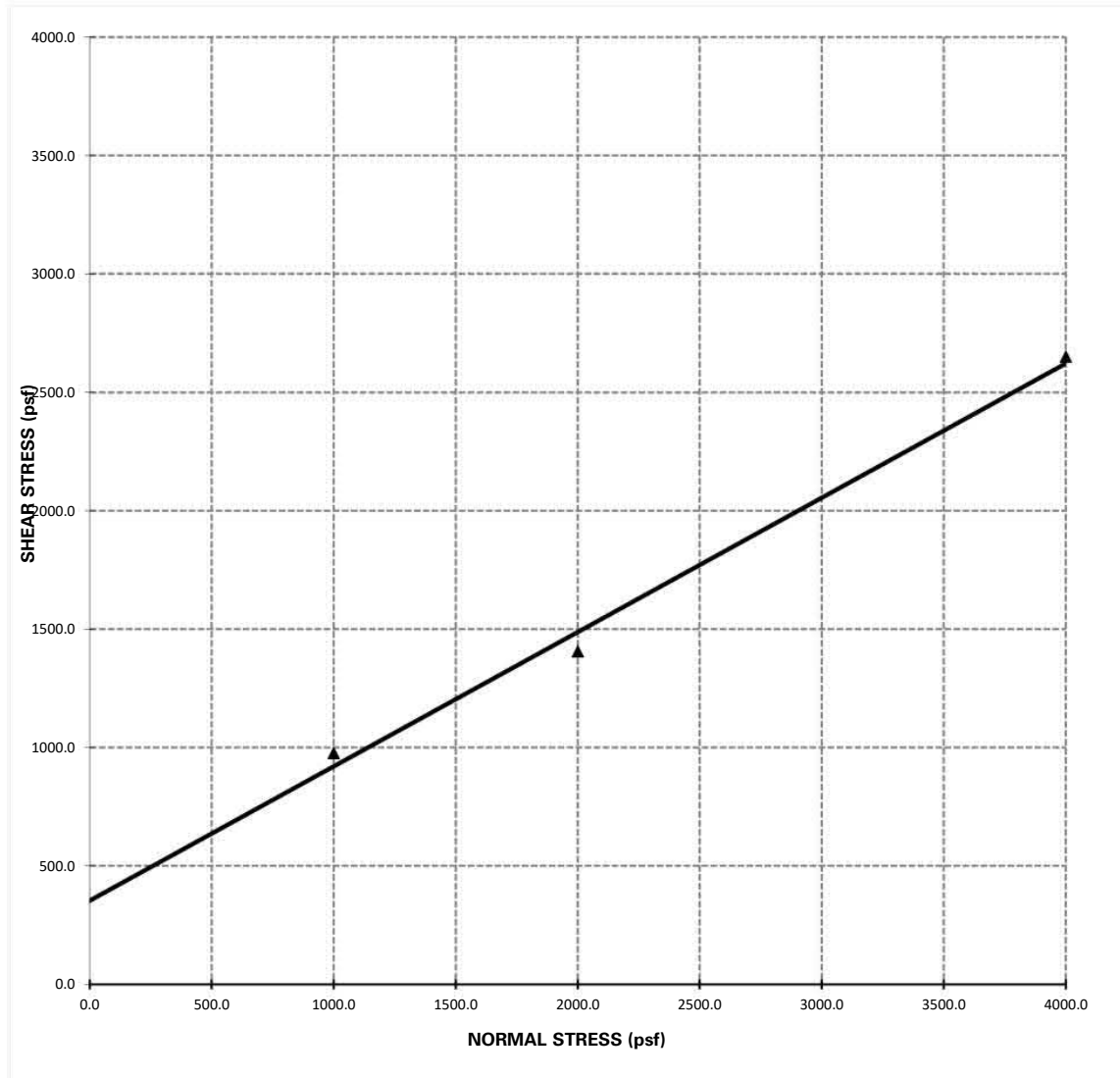

Shear Strength: $\Phi = 30^{\circ}$ $C = 354$ psf

- Notes:**
- 1 - The soil specimen used in the shear box was a ring sample remolded to approximately 90% relative compaction from a bulk sample collected during the field investigation.
 - 2 - The above reflect direct shear strength at saturated conditions.
 - 3 - The tests were run at a shear rate of 0.35 in/min.



DIRECT SHEAR TEST

Project Name: Guajome Crest
Project Number: 3775-SD

Sample Location: TP-7 @ 2-4 feet
Date Tested: 4/22/2022

PEAK VALUE

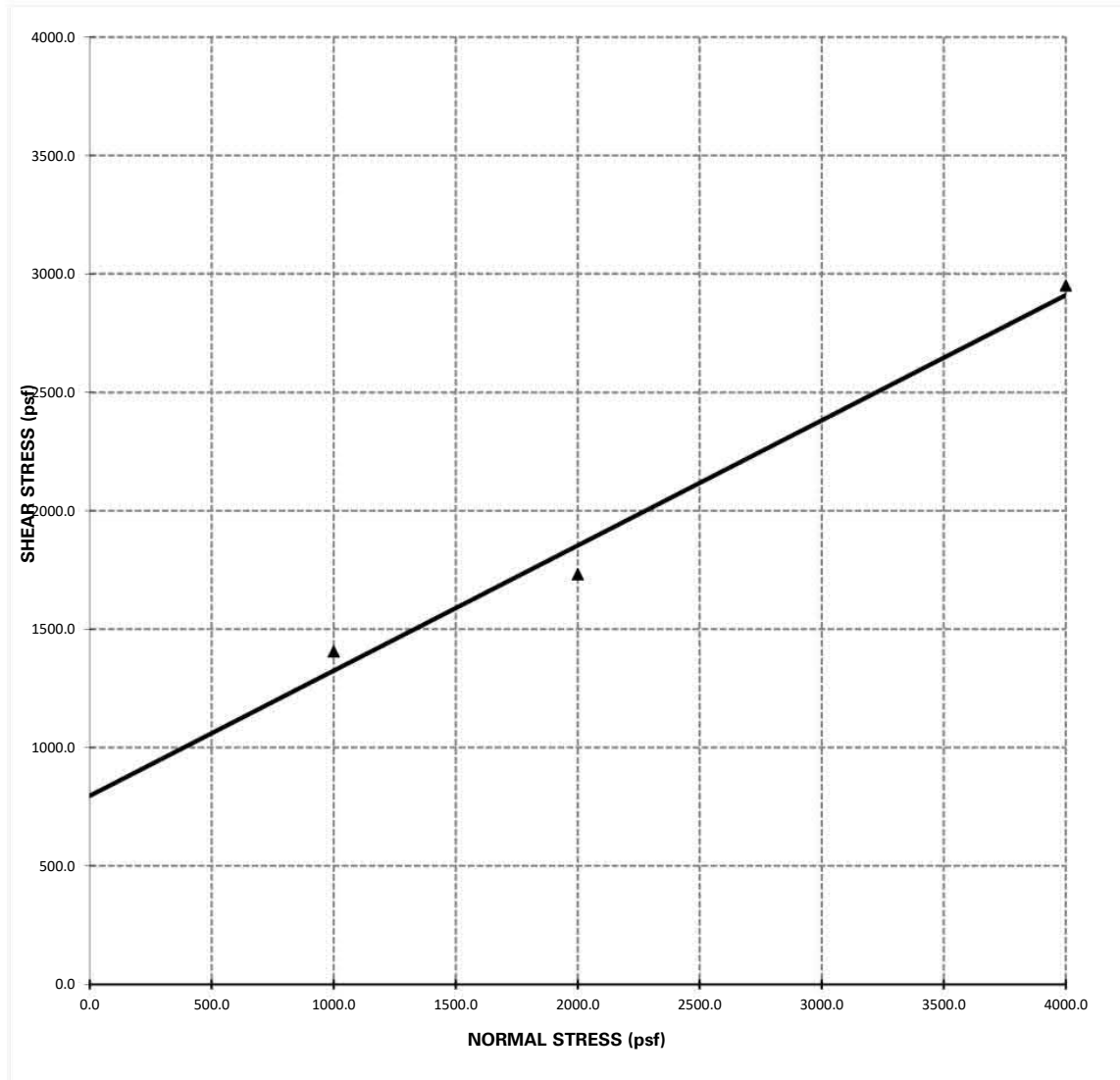

Shear Strength: $\Phi = 28^\circ$ $C = 796$ psf

- Notes:**
- 1 - The soil specimen used in the shear box was a ring sample remolded to approximately 90% relative compaction from a bulk sample collected during the field investigation.
 - 2 - The above reflect direct shear strength at saturated conditions.
 - 3 - The tests were run at a shear rate of 0.01 in/min.



ATTERBERG LIMITS DATA

Field Classification	<u>Light Gray Silty M-C Sand</u>	Job No.	<u>3775-SD</u>
Sample Number	<u>TP-1 BB-1</u>	Client	<u>Rincon Homes</u>
Sample Type	<u></u>	Project	<u>Guajome Crest</u>
Location	<u>Oceanside, CA</u>		
Tested by:	<u>CH</u>		

	Plastic Limit		Liquid Limit			
	1	2	1	2	3	4
Number of Blows			0	0	0	0
Determination	1	2	1	2	3	4
Dish						
Wt. of Dish + Wet Soil	0.00	0.00	0.00	0.00	0.00	0
Wt. of Dish + Dry Soil	0.00	0.00	0.00	0.00	0.00	0
Wt. of Moisture	0.00	0.00	0.00	0.00	0.00	0.00
Wt. of Dish	0.85	0.85	0.86	0.86	0.86	0.86
Wt. of Dry Soil	-0.85	-0.85	-0.86	-0.86	-0.86	-0.86
Moisture Content %	0.0	0.0	0.0	0.0	0.0	0.0

Liquid Limit Graph

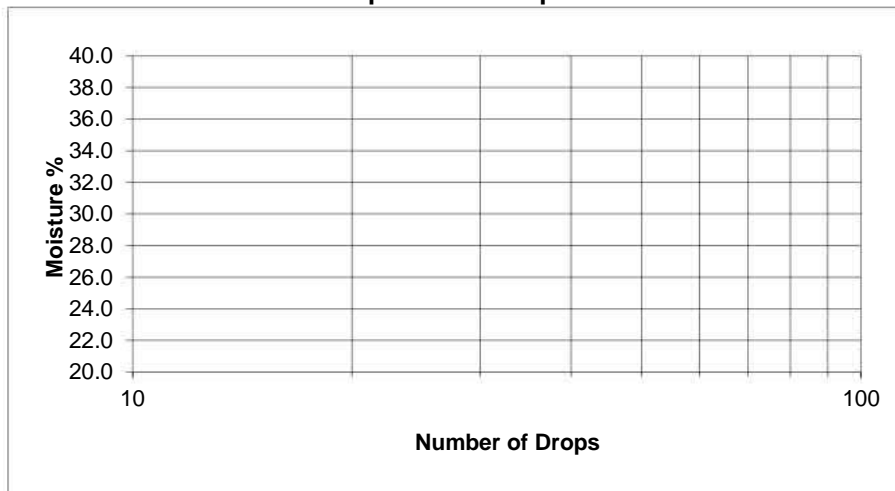

Liquid Limit
0

Plastic Limit
0

Plasticity Index
NON-PLASTIC

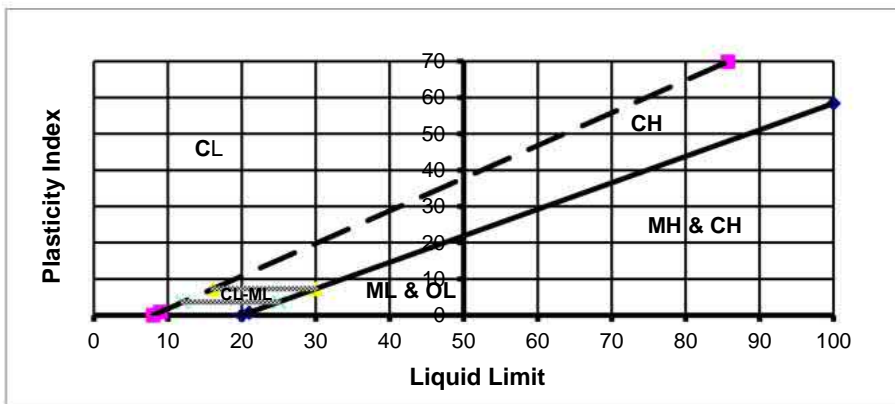



ATTERBERG LIMITS DATA

Field Classification	Tan Silty M-C Sand	Job No.	3775-SD
Sample Number	TP-6 BB-1	Client	Rincon Homes
Sample Type		Project	Guajome Crest
Location	Oceanside, CA		
Tested by:	CH		

Number of Blows	Plastic Limit		Liquid Limit			
	1	2	1	2	3	4
Determination						
Dish						
Wt. of Dish + Wet Soil	0.00	0.00	0.00	0.00	0.00	0
Wt. of Dish + Dry Soil	0.00	0.00	0.00	0.00	0.00	0
Wt. of Moisture	0.00	0.00	0.00	0.00	0.00	0.00
Wt. of Dish	0.85	0.85	0.86	0.86	0.86	0.86
Wt. of Dry Soil	-0.85	-0.85	-0.86	-0.86	-0.86	-0.86
Moisture Content %	0.0	0.0	0.0	0.0	0.0	0.0

Liquid Limit Graph

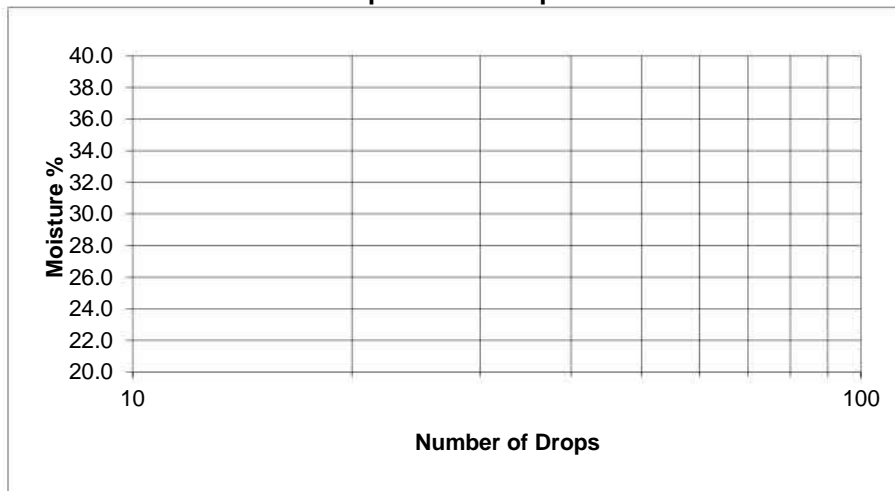

Liquid Limit
0

Plastic Limit
0

Plasticity Index
Non-plastic

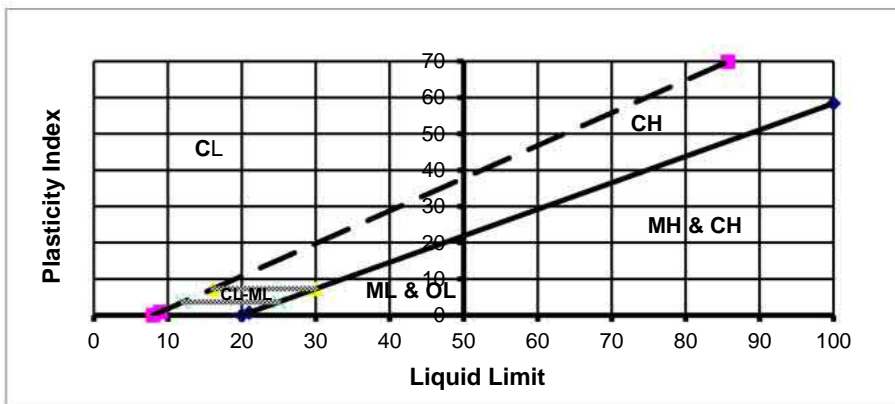



Results Only Soil Testing for Guajame Crest

April 18, 2022

Prepared for:

**Chris Livesey
GeoTek, Inc.**

**1384 Poinsettia Ave, Suite A
Vista, CA, 92081
clivesey@geotekusa.com**

**Project X Job#: S220414L
Client Job or PO#: 3775-SD**

Respectfully Submitted,

Eduardo Hernandez, M.Sc., P.E.
Sr. Corrosion Consultant
NACE Corrosion Technologist #16592
Professional Engineer
California No. M37102
ehernandez@projectxcorrosion.com





Soil Analysis Lab Results

Client: GeoTek, Inc.
 Job Name: Guajame Crest
 Client Job Number: 3775-SD
 Project X Job Number: S220414L
 April 18, 2022

Bore# / Description	Method	ASTM D4327		ASTM D4327		ASTM G187		ASTM G51	ASTM G200	SM 4500-D	ASTM D4327	ASTM D6919	ASTM D6919	ASTM D6919	ASTM D6919	ASTM D6919	ASTM D6919	ASTM D4327	ASTM D4327
		Sulfates SO ₄ ²⁻		Chlorides Cl ⁻		Resistivity As Rec'd Minimum		pH	Redox	Sulfide S ²⁻	Nitrate NO ₃ ⁻	Ammonium NH ₄ ⁺	Lithium Li ⁺	Sodium Na ⁺	Potassium K ⁺	Magnesium Mg ²⁺	Calcium Ca ²⁺	Fluoride F ₂ ⁻	Phosphate PO ₄ ³⁻
Depth	(ft)	(mg/kg)	(wt%)	(mg/kg)	(wt%)	(Ohm-cm)	(Ohm-cm)		(mV)	(mg/kg)	(mg/kg)	(mg/kg)	(mg/kg)	(mg/kg)	(mg/kg)	(mg/kg)	(mg/kg)	(mg/kg)	(mg/kg)
TP-6 BB-1	3-5	4.5	0.0005	3.2	0.0003	54,940	15,410	7.8	102	0.42	0.1	1.7	ND	73.9	11.7	13.9	2.0	1.1	1.7
TP-7 BB-1	2-4	17.7	0.0018	9.2	0.0009	16,080	4,154	9.2	108	0.33	1.1	8.0	0.01	94.9	4.5	4.8	0.5	1.7	2.6

Cations and Anions, except Sulfide and Bicarbonate, tested with Ion Chromatography
 mg/kg = milligrams per kilogram (parts per million) of dry soil weight
 ND = 0 = Not Detected | NT = Not Tested | Unk = Unknown
 Chemical Analysis performed on 1:3 Soil-To-Water extract
 PPM = mg/kg (soil) = mg/L (Liquid)

APPENDIX C

GENERAL EARTHWORK GRADING GUIDELINES

GENERAL GRADING GUIDELINES

Guidelines presented herein are intended to address general construction procedures for earthwork construction. Specific situations and conditions often arise which cannot reasonably be discussed in general guidelines, when anticipated these are discussed in the text of the report. Often unanticipated conditions are encountered which may necessitate modification or changes to these guidelines. It is our hope that these will assist the contractor to more efficiently complete the project by providing a reasonable understanding of the procedures that would be expected during earthwork and the testing and observation used to evaluate those procedures.

General

Grading should be performed to at least the minimum requirements of governing agencies, the California Building Code, CBC (2019) and the guidelines presented below.

Preconstruction Meeting

A preconstruction meeting should be held prior to site earthwork. Any questions the contractor has regarding our recommendations, general site conditions, apparent discrepancies between reported and actual conditions and/or differences in procedures the contractor intends to use should be brought up at that meeting. The contractor (including the main onsite representative) should review our report and these guidelines in advance of the meeting. Any comments the contractor may have regarding these guidelines should be brought up at that meeting.

Grading Observation and Testing

1. Observation of the fill placement should be provided by our representative during grading. Verbal communication during the course of each day will be used to inform the contractor of test results. The contractor should receive a copy of the "Daily Field Report" indicating results of field density tests that day. If our representative does not provide the contractor with these reports, our office should be notified.
2. Testing and observation procedures are, by their nature, specific to the work or area observed and location of the tests taken, variability may occur in other locations. The contractor is responsible for the uniformity of the grading operations; our observations and test results are intended to evaluate the contractor's overall level of efforts during grading. The contractor's personnel are the only individuals participating in all aspect of site work. Compaction testing and observation should not be considered as relieving the contractor's responsibility to properly compact the fill.
3. Cleanouts, processed ground to receive fill, key excavations, and subdrains should be observed by our representative prior to placing any fill. It will be the contractor's responsibility to notify our representative or office when such areas are ready for observation.
4. Density tests may be made on the surface material to receive fill, as considered warranted by this firm.
5. In general, density tests would be made at maximum intervals of two feet of fill height or every 1,000 cubic yards of fill placed. Criteria will vary depending on soil conditions and size of the fill. More frequent testing may be performed. In any case, an adequate number of field density tests should be made to evaluate the required compaction and moisture content is generally being obtained.

6. Laboratory testing to support field test procedures will be performed, as considered warranted, based on conditions encountered (e.g. change of material sources, types, etc.) Every effort will be made to process samples in the laboratory as quickly as possible and in progress construction projects are our first priority. However, laboratory workloads may cause in delays and some soils may require a **minimum of 48 to 72 hours to complete test procedures**. Whenever possible, our representative(s) should be informed in advance of operational changes that might result in different source areas for materials.
7. Procedures for testing of fill slopes are as follows:
 - a) Density tests should be taken periodically during grading on the flat surface of the fill, three to five feet horizontally from the face of the slope.
 - b) If a method other than over building and cutting back to the compacted core is to be employed, slope compaction testing during construction should include testing the outer six inches to three feet in the slope face to determine if the required compaction is being achieved.
8. Finish grade testing of slopes and pad surfaces should be performed after construction is complete.

Site Clearing

1. All vegetation, and other deleterious materials, should be removed from the site. If material is not immediately removed from the site it should be stockpiled in a designated area(s) well outside of all current work areas and delineated with flagging or other means. Site clearing should be performed in advance of any grading in a specific area.
2. Efforts should be made by the contractor to remove all organic or other deleterious material from the fill, as even the most diligent efforts may result in the incorporation of some materials. This is especially important when grading is occurring near the natural grade. All equipment operators should be aware of these efforts. Laborers may be required as root pickers.
3. Nonorganic debris or concrete may be placed in deeper fill areas provided the procedures used are observed and found acceptable by our representative. Typical procedures are similar to those indicated on Plate G-4.

Treatment of Existing Ground

1. Following site clearing, all surficial deposits of alluvium and colluvium as well as weathered or creep effected bedrock, should be removed (see Plates G-1, G-2 and G-3) unless otherwise specifically indicated in the text of this report.
2. In some cases, removal may be recommended to a specified depth (e.g. flat sites where partial alluvial removals may be sufficient). The contractor should not exceed these depths unless directed otherwise by our representative.
3. Groundwater existing in alluvial areas may make excavation difficult. Deeper removals than indicated in the text of the report may be necessary due to saturation during winter months.
4. Subsequent to removals, the natural ground should be processed to a depth of six inches, moistened to near optimum moisture conditions and compacted to fill standards.
5. Exploratory back hoe or dozer trenches still remaining after site removal should be excavated and filled with compacted fill if they can be located.

Subdrainage

1. Subdrainage systems should be provided in canyon bottoms prior to placing fill, and behind buttress and stabilization fills and in other areas indicated in the report. Subdrains should conform to schematic diagrams G-1 and G-5, and be acceptable to our representative.
2. For canyon subdrains, runs less than 500 feet may use six-inch pipe. Typically, runs in excess of 500 feet should have the lower end as eight-inch minimum.
3. Filter material should be clean, 1/2 to 1-inch gravel wrapped in a suitable filter fabric. Class 2 permeable filter material per California Department of Transportation Standards tested by this office to verify its suitability, may be used without filter fabric. A sample of the material should be provided to the Soils Engineer by the contractor at least two working days before it is delivered to the site. The filter should be clean with a wide range of sizes.
4. Approximate delineation of anticipated subdrain locations may be offered at 40-scale plan review stage. During grading, this office would evaluate the necessity of placing additional drains.
5. All subdrainage systems should be observed by our representative during construction and prior to covering with compacted fill.
6. Subdrains should outlet into storm drains where possible. Outlets should be located and protected. The need for backflow preventers should be assessed during construction.
7. Consideration should be given to having subdrains located by the project surveyors.

Fill Placement

1. Unless otherwise indicated, all site soil and bedrock may be reused for compacted fill; however, some special processing or handling may be required (see text of report).
2. Material used in the compacting process should be evenly spread, moisture conditioned, processed, and compacted in thin lifts six (6) to eight (8) inches in compacted thickness to obtain a uniformly dense layer. The fill should be placed and compacted on a nearly horizontal plane, unless otherwise found acceptable by our representative.
3. If the moisture content or relative density varies from that recommended by this firm, the contractor should rework the fill until it is in accordance with the following:
 - a) Moisture content of the fill should be at or above optimum moisture. Moisture should be evenly distributed without wet and dry pockets. Pre-watering of cut or removal areas should be considered in addition to watering during fill placement, particularly in clay or dry surficial soils. The ability of the contractor to obtain the proper moisture content will control production rates.
 - b) Each six-inch layer should be compacted to at least 90 percent of the maximum dry density in compliance with the testing method specified by the controlling governmental agency. In most cases, the testing method is ASTM Test Designation D 1557.
4. Rock fragments less than eight inches in diameter may be utilized in the fill, provided:
 - a) They are not placed in concentrated pockets;
 - b) There is a sufficient percentage of fine-grained material to surround the rocks;
 - c) The distribution of the rocks is observed by, and acceptable to, our representative.
5. Rocks exceeding eight (8) inches in diameter should be taken off site, broken into smaller fragments, or placed in accordance with recommendations of this firm in areas designated suitable for rock disposal (see Plate G-4). On projects where significant large quantities of oversized materials are anticipated, alternate guidelines for placement may be included. If

significant oversize materials are encountered during construction, these guidelines should be requested.

6. In clay soil, dry or large chunks or blocks are common. If in excess of eight (8) inches minimum dimension, then they are considered as oversized. Sheepsfoot compactors or other suitable methods should be used to break up blocks. When dry, they should be moisture conditioned to provide a uniform condition with the surrounding fill.

Slope Construction

1. The contractor should obtain a minimum relative compaction of 90 percent out to the finished slope face of fill slopes. This may be achieved by either overbuilding the slope and cutting back to the compacted core, or by direct compaction of the slope face with suitable equipment.
2. Slopes trimmed to the compacted core should be overbuilt by at least three (3) feet with compaction efforts out to the edge of the false slope. Failure to properly compact the outer edge results in trimming not exposing the compacted core and additional compaction after trimming may be necessary.
3. If fill slopes are built "at grade" using direct compaction methods, then the slope construction should be performed so that a constant gradient is maintained throughout construction. Soil should not be "spilled" over the slope face nor should slopes be "pushed out" to obtain grades. Compaction equipment should compact each lift along the immediate top of slope. Slopes should be back rolled or otherwise compacted at approximately every 4 feet vertically as the slope is built.
4. Corners and bends in slopes should have special attention during construction as these are the most difficult areas to obtain proper compaction.
5. Cut slopes should be cut to the finished surface. Excessive undercutting and smoothing of the face with fill may necessitate stabilization.

Keyways, Buttress and Stabilization Fills

Keyways are needed to provide support for fill slope and various corrective procedures.

1. Side-hill fills should have an equipment-width key at their toe excavated through all surficial soil and into competent material and tilted back into the hill (Plates G-2, G-3). As the fill is elevated, it should be benched through surficial soil and slopewash, and into competent bedrock or other material deemed suitable by our representatives (See Plates G-1, G-2, and G-3).
2. Fill over cut slopes should be constructed in the following manner:
 - a) All surficial soils and weathered rock materials should be removed at the cut-fill interface.
 - b) A key at least one and one-half (1.5) equipment width wide (or as needed for compaction), and tipped at least one (1) foot into slope, should be excavated into competent materials and observed by our representative.
 - c) The cut portion of the slope should be excavated prior to fill placement to evaluate if stabilization is necessary. The contractor should be responsible for any additional earthwork created by placing fill prior to cut excavation. (see Plate G-3 for schematic details.)
3. Daylight cut lots above descending natural slopes may require removal and replacement of the outer portion of the lot. A schematic diagram for this condition is presented on Plate G-2.

4. A basal key is needed for fill slopes extending over natural slopes. A schematic diagram for this condition is presented on Plate G-2.
5. All fill slopes should be provided with a key unless within the body of a larger overall fill mass. Please refer to Plate G-3 for specific guidelines.

Anticipated buttress and stabilization fills are discussed in the text of the report. The need to stabilize other proposed cut slopes will be evaluated during construction. Plate G-5 shows a schematic of buttress construction.

1. All backcuts should be excavated at gradients of 1:1 or flatter. The backcut configuration should be determined based on the design, exposed conditions, and need to maintain a minimum fill width and provide working room for the equipment.
2. On longer slopes, backcuts and keyways should be excavated in maximum 250 feet long segments. The specific configurations will be determined during construction.
3. All keys should be a minimum of two (2) feet deep at the toe and slope toward the heel at least one foot or two (2%) percent, whichever is greater.
4. Subdrains are to be placed for all stabilization slopes exceeding 10 feet in height. Lower slopes are subject to review. Drains may be required. Guidelines for subdrains are presented on Plate G-5.
5. Benching of backcuts during fill placement is required.

Lot Capping

1. When practical, the upper three (3) feet of material placed below finish grade should be comprised of the least expansive material available. Preferably, highly and very highly expansive materials should not be used. We will attempt to offer advice based on visual evaluations of the materials during grading, but it must be realized that laboratory testing is needed to evaluate the expansive potential of soil. Minimally, this testing takes two (2) to four (4) days to complete.
2. Transition lots (cut and fill) both per plan and those created by remedial grading (e.g. lots above stabilization fills, along daylight lines, above natural slopes, etc.) should be capped with a minimum three foot thick compacted fill blanket.
3. Cut pads should be observed by our representative(s) to evaluate the need for overexcavation and replacement with fill. This may be necessary to reduce water infiltration into highly fractured bedrock or other permeable zones, and/or due to differing expansive potential of materials beneath a structure. The overexcavation should be at least three feet. Deeper overexcavation may be recommended in some cases.

ROCK PLACEMENT AND ROCK FILL GUIDELINES

If large quantities of oversize material would be generated during grading, it's likely that such materials may require special handling for burial. Although alternatives may be developed in the field, the following methods of rock disposal are recommended on a preliminary basis.

Limited Larger Rock

When materials encountered are principally soil with limited quantities of larger rock fragments or boulders, placement in windrows is recommended. The following procedures should be applied:

1. Oversize rock (greater than 8 inches) should be placed in windrows.
 - a) Windrows are rows of single file rocks placed to avoid nesting or clusters of rock.



- b) Each adjacent rock should be approximately the same size (within ~one foot in diameter).
- c) The maximum rock size allowed in windrows is four feet
2. A minimum vertical distance of three feet between lifts should be maintained. Also, the windrows should be offset from lift to lift. Rock windrows should not be closer than 15 feet to the face of fill slopes and sufficient space must be maintained for proper slope construction (see Plate G-4).
3. Rocks greater than eight inches in diameter should not be placed within seven feet of the finished subgrade for a roadway or pads and should be held below the depth of the lowest utility. This will allow easier trenching for utility lines.
4. Rocks greater than four feet in diameter should be broken down, if possible, or they may be placed in a dozer trench. Each trench should be excavated into the compacted fill a minimum of one foot deeper than the largest diameter of rock.
 - a) The rock should be placed in the trench and granular fill materials (SE>30) should be flooded into the trench to fill voids around the rock.
 - b) The over size rock trenches should be no closer together than 15 feet from any slope face.
 - c) Trenches at higher elevation should be staggered and there should be a minimum of four feet of compacted fill between the top of the one trench and the bottom of the next higher trench.
 - d) It would be necessary to verify 90 percent relative compaction in these pits. A 24 to 72 hour delay to allow for water dissipation should be anticipated prior to additional fill placement.

Structural Rock Fills

If the materials generated for placement in structural fills contains a significant percentage of material more than six (6) inches in one dimension, then placement using conventional soil fill methods with isolated windrows would not be feasible. In such cases the following could be considered:

1. Mixes of large rock or boulders may be placed as rock fill. They should be below the depth of all utilities both on pads and in roadways and below any proposed swimming pools or other excavations. If these fills are placed within seven (7) feet of finished grade, they may affect foundation design.
2. Rock fills are required to be placed in horizontal layers that should **not exceed two feet in thickness, or the maximum rock size present, which ever is less**. All rocks exceeding two feet should be broken down to a smaller size, windrowed (see above), or disposed of in non-structural fill areas. Localized larger rock up to 3 feet in largest dimension may be placed in rock fill as follows:
 - a) individual rocks are placed in a given lift so as to be roughly 50% exposed above the typical surface of the fill ,
 - b) loaded rock trucks or alternate compactors are worked around the rock on all sides to the satisfaction of the soil engineer,
 - c) the portion of the rock above grade is covered with a second lift.
3. Material placed in each lift should be well graded. No unfilled spaces (voids) should be permitted in the rock fill.

Compaction Procedures

Compaction of rock fills is largely procedural. The following procedures have been found to generally produce satisfactory compaction.

1. Provisions for routing of construction traffic over the fill should be implemented.
 - a) Placement should be by rock trucks crossing the lift being placed and dumping at its edge.
 - b) The trucks should be routed so that each pass across the fill is via a different path and that all areas are uniformly traversed.
 - c) The dumped piles should be knocked down and spread by a large dozer (D-8 or larger suggested). (Water should be applied before and during spreading.)
2. Rock fill should be generously watered (sluiced)
 - a) Water should be applied by water trucks to the:
 - i) dump piles,
 - ii) front face of the lift being placed and,
 - iii) surface of the fill prior to compaction.
 - b) No material should be placed without adequate water.
 - c) The number of water trucks and water supply should be sufficient to provide constant water.
 - d) Rock fill placement should be suspended when water trucks are unavailable:
 - i) for more than 5 minutes straight, or,
 - ii) for more than 10 minutes/hour.
3. In addition to the truck pattern and at the discretion of the soil engineer, large, rubber tired compactors may be required.
 - a) The need for this equipment will depend largely on the ability of the operators to provide complete and uniform coverage by wheel rolling with the trucks.
 - b) Other large compactors will also be considered by the soil engineer provided that required compaction is achieved.
4. Placement and compaction of the rock fill is largely procedural. Observation by trenching should be made to check:
 - a) the general segregation of rock size,
 - b) for any unfilled spaces between the large blocks, and
 - c) the matrix compaction and moisture content.
5. Test fills may be required to evaluate relative compaction of finer grained zones or as deemed appropriate by the soil engineer.
 - a) A lift should be constructed by the methods proposed, as proposed
6. Frequency of the test trenching is to be at the discretion of the soil engineer. Control areas may be used to evaluate the contractor's procedures.
7. A minimum horizontal distance of 15 feet should be maintained from the face of the rock fill and any finish slope face. At least the outer 15 feet should be built of conventional fill materials.

Piping Potential and Filter Blankets

Where conventional fill is placed over rock fill, the potential for piping (migration) of the fine grained material from the conventional fill into rock fills will need to be addressed.

The potential for particle migration is related to the grain size comparisons of the materials present and in contact with each other. Provided that 15 percent of the finer soil is larger than the effective

pore size of the coarse soil, then particle migration is substantially mitigated. This can be accomplished with a well-graded matrix material for the rock fill and a zone of fill similar to the matrix above it. The specific gradation of the fill materials placed during grading must be known to evaluate the need for any type of filter that may be necessary to cap the rock fills. This, unfortunately, can only be accurately determined during construction.

In the event that poorly graded matrix is used in the rock fills, properly graded filter blankets 2 to 3 feet thick separating rock fills and conventional fill may be needed. As an alternative, use of two layers of filter fabric (Mirafi 700 x or equivalent) could be employed on top of the rock fill. In order to mitigate excess puncturing, the surface of the rock fill should be well broken down and smoothed prior to placing the filter fabric. The first layer of the fabric may then be placed and covered with relatively permeable fill material (with respect to overlying material) 1 to 2 feet thick. The relative permeable material should be compacted to fill standards. The second layer of fabric should be placed and conventional fill placement continued.

Subdrainage

Rock fill areas should be tied to a subdrainage system. If conventional fill is placed that separates the rock from the main canyon subdrain, then a secondary system should be installed. A system consisting of an adequately graded base (3 to 4 percent to the lower side) with a collector system and outlets may suffice.

Additionally, at approximately every 25 foot vertical interval, a collector system with outlets should be placed at the interface of the rock fill and the conventional fill blanketing a fill slope.

Monitoring

Depending upon the depth of the rock fill and other factors, monitoring for settlement of the fill areas may be needed following completion of grading. Typically, if rock fill depths exceed 40 feet, monitoring would be recommended prior to construction of any settlement sensitive improvements. Delays of 3 to 6 months or longer can be expected prior to the start of construction.

UTILITY TRENCH CONSTRUCTION AND BACKFILL

Utility trench excavation and backfill is the contractor's responsibility. The geotechnical consultant typically provides periodic observation and testing of these operations. While efforts are made to make sufficient observations and tests to verify that the contractors' methods and procedures are adequate to achieve proper compaction, it is typically impractical to observe all backfill procedures. As such, it is critical that the contractor use consistent backfill procedures.

Compaction methods vary for trench compaction and experience indicates many methods can be successful. However, procedures that "worked" on previous projects may or may not prove effective on a given site. The contractor(s) should outline the procedures proposed, so that we may discuss them **prior** to construction. We will offer comments based on our knowledge of site conditions and experience.

1. Utility trench backfill in slopes, structural areas, in streets and beneath flat work or hardscape should be brought to at least optimum moisture and compacted to at least 90 percent of the laboratory standard. Soil should be moisture conditioned prior to placing in the trench.

2. Flooding and jetting are not typically recommended or acceptable for native soils. Flooding or jetting may be used with select sand having a Sand Equivalent (SE) of 30 or higher. This is typically limited to the following uses:
 - a) shallow (12 + inches) under slab interior trenches and,
 - b) as bedding in pipe zone.The water should be allowed to dissipate prior to pouring slabs or completing trench compaction.
3. Care should be taken not to place soils at high moisture content within the upper three feet of the trench backfill in street areas, as overly wet soils may impact subgrade preparation. Moisture may be reduced to 2% below optimum moisture in areas to be paved within the upper three feet below sub grade.
4. Sand backfill should not be allowed in exterior trenches adjacent to and within an area extending below a 1:1 projection from the outside bottom edge of a footing, unless it is similar to the surrounding soil.
5. Trench compaction testing is generally at the discretion of the geotechnical consultant. Testing frequency will be based on trench depth and the contractor's procedures. A probing rod would be used to assess the consistency of compaction between tested areas and untested areas. If zones are found that are considered less compact than other areas, this would be brought to the contractor's attention.

JOB SAFETY

General

Personnel safety is a primary concern on all job sites. The following summaries are safety considerations for use by all our employees on multi-employer construction sites. On ground personnel are at highest risk of injury and possible fatality on grading construction projects. The company recognizes that construction activities will vary on each site and that job site safety is the contractor's responsibility. However, it is, imperative that all personnel be safety conscious to avoid accidents and potential injury.

In an effort to minimize risks associated with geotechnical testing and observation, the following precautions are to be implemented for the safety of our field personnel on grading and construction projects.

1. Safety Meetings: Our field personnel are directed to attend the contractor's regularly scheduled safety meetings.
2. Safety Vests: Safety vests are provided for and are to be worn by our personnel while on the job site.
3. Safety Flags: Safety flags are provided to our field technicians; one is to be affixed to the vehicle when on site, the other is to be placed atop the spoil pile on all test pits.

In the event that the contractor's representative observes any of our personnel not following the above, we request that it be brought to the attention of our office.

Test Pits Location, Orientation and Clearance

The technician is responsible for selecting test pit locations. The primary concern is the technician's safety. However, it is necessary to take sufficient tests at various locations to obtain a representative sampling of the fill. As such, efforts will be made to coordinate locations with the grading contractors authorized representatives (e.g. dump man, operator, supervisor, grade checker, etc.),



and to select locations following or behind the established traffic pattern, preferably outside of current traffic. The contractors authorized representative should direct excavation of the pit and safety during the test period. Again, safety is the paramount concern.

Test pits should be excavated so that the spoil pile is placed away from oncoming traffic. The technician's vehicle is to be placed next to the test pit, opposite the spoil pile. This necessitates that the fill be maintained in a drivable condition. Alternatively, the contractor may opt to park a piece of equipment in front of test pits, particularly in small fill areas or those with limited access.

A zone of non-encroachment should be established for all test pits (see diagram below). No grading equipment should enter this zone during the test procedure. The zone should extend outward to the sides approximately 50 feet from the center of the test pit and 100 feet in the direction of traffic flow. This zone is established both for safety and to avoid excessive ground vibration, which typically decreases test results.

TEST PIT SAFETY PLAN

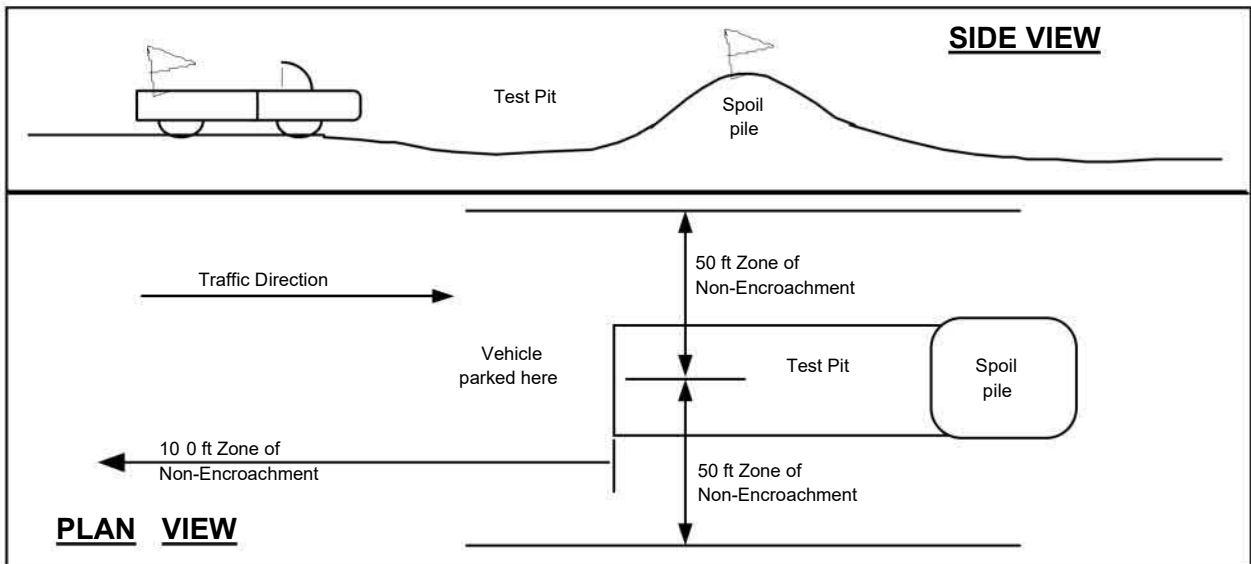

Slope Tests

When taking slope tests, the technician should park their vehicle directly above or below the test location on the slope. The contractor's representative should effectively keep all equipment at a safe operation distance (e.g. 50 feet) away from the slope during testing.

The technician is directed to withdraw from the active portion of the fill as soon as possible following testing. The technician's vehicle should be parked at the perimeter of the fill in a highly visible location.

Trench Safety

It is the contractor's responsibility to provide safe access into trenches where compaction testing is needed. Trenches for all utilities should be excavated in accordance with CAL-OSHA and any other applicable safety standards. Safe conditions will be required to enable compaction testing of the trench backfill.

All utility trench excavations in excess of 5 feet deep, which a person enters, are to be shored or laid back. Trench access should be provided in accordance with OSHA standards. Our personnel are directed not to enter any trench by being lowered or "riding down" on the equipment.

Our personnel are directed not to enter any excavation which;

1. is 5 feet or deeper unless shored or laid back,
2. exit points or ladders are not provided,
3. displays any evidence of instability, has any loose rock or other debris which could fall into the trench, or
4. displays any other evidence of any unsafe conditions regardless of depth.

If the contractor fails to provide safe access to trenches for compaction testing, our company policy requires that the soil technician withdraws and notifies their supervisor. The contractor's representative will then be contacted in an effort to affect a solution. All backfill not tested due to safety concerns or other reasons is subject to reprocessing and/or removal.

Procedures

In the event that the technician's safety is jeopardized or compromised as a result of the contractor's failure to comply with any of the above, the technician is directed to inform both the developer's and contractor's representatives. If the condition is not rectified, the technician is required, by company policy, to immediately withdraw and notify their supervisor. The contractor's representative will then be contacted in an effort to affect a solution. No further testing will be performed until the situation is rectified. Any fill placed in the interim can be considered unacceptable and subject to reprocessing, recompaction or removal.

In the event that the soil technician does not comply with the above or other established safety guidelines, we request that the contractor bring this to technician's attention and notify our project manager or office. Effective communication and coordination between the contractors' representative and the field technician(s) is strongly encouraged in order to implement the above safety program and safety in general.

The safety procedures outlined above should be discussed at the contractor's safety meetings. This will serve to inform and remind equipment operators of these safety procedures particularly the zone of non-encroachment.

The safety procedures outlined above should be discussed at the contractor's safety meetings. This will serve to inform and remind equipment operators of these safety procedures particularly the zone of non-encroachment.

ALTERNATES

Finish Grade

Original Ground

Loose Surface Materials

Suitable Material

4 feet typical

Construct Benches where slope exceeds 5:1

Slope to Drain

Suitable Material

Bottom of Cleanout to Be At Least 1.5 Times the Width of Compaction Equipment

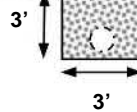

6" Perforated Pipe in 9 cubic feet per Lineal Foot Clean Gravel Wrapped in Filter Fabric

Finish Grade

Original Ground

Loose Surface Materials

Construct Benches where slope exceeds 5:1

Slope to Drain

Suitable Material

4 feet typical

Bottom of Cleanout to Be At Least 1.5 Times the Width of Compaction Equipment

6" Perforated Pipe in 9 cubic feet per Lineal Foot Clean Gravel Wrapped in Filter Fabric



1384 Poinsettia Avenue, Suite A
Vista, California 92083

**TYPICAL CANYON
CLEANOUT**

**STANDARD GRADING
GUIDELINES
PLATE G-1**

TYPICAL FILL SLOPE OVER NATURAL DESCENDING SLOPE

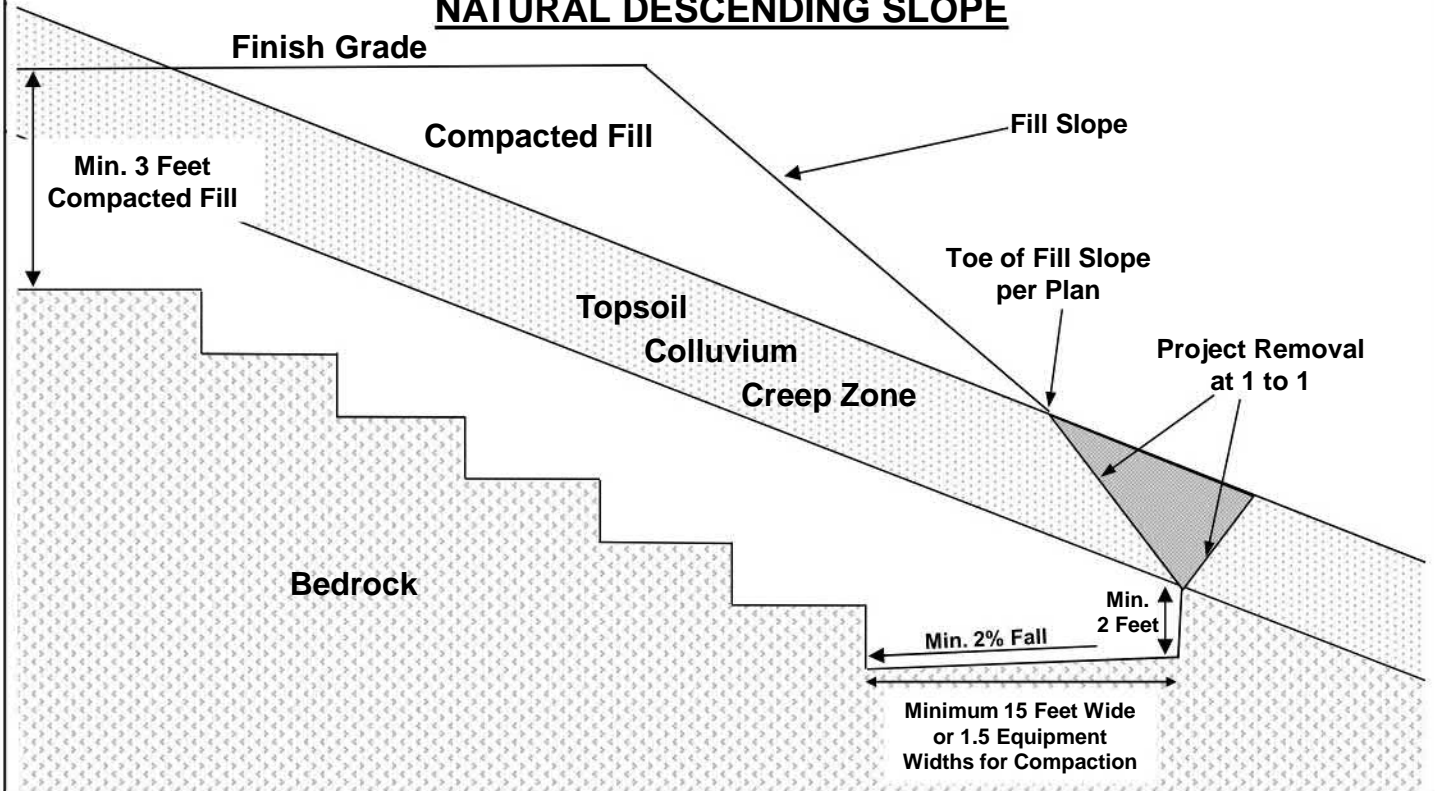

DAYLIGHT CUT AREA OVER NATURAL DESCENDING SLOPE

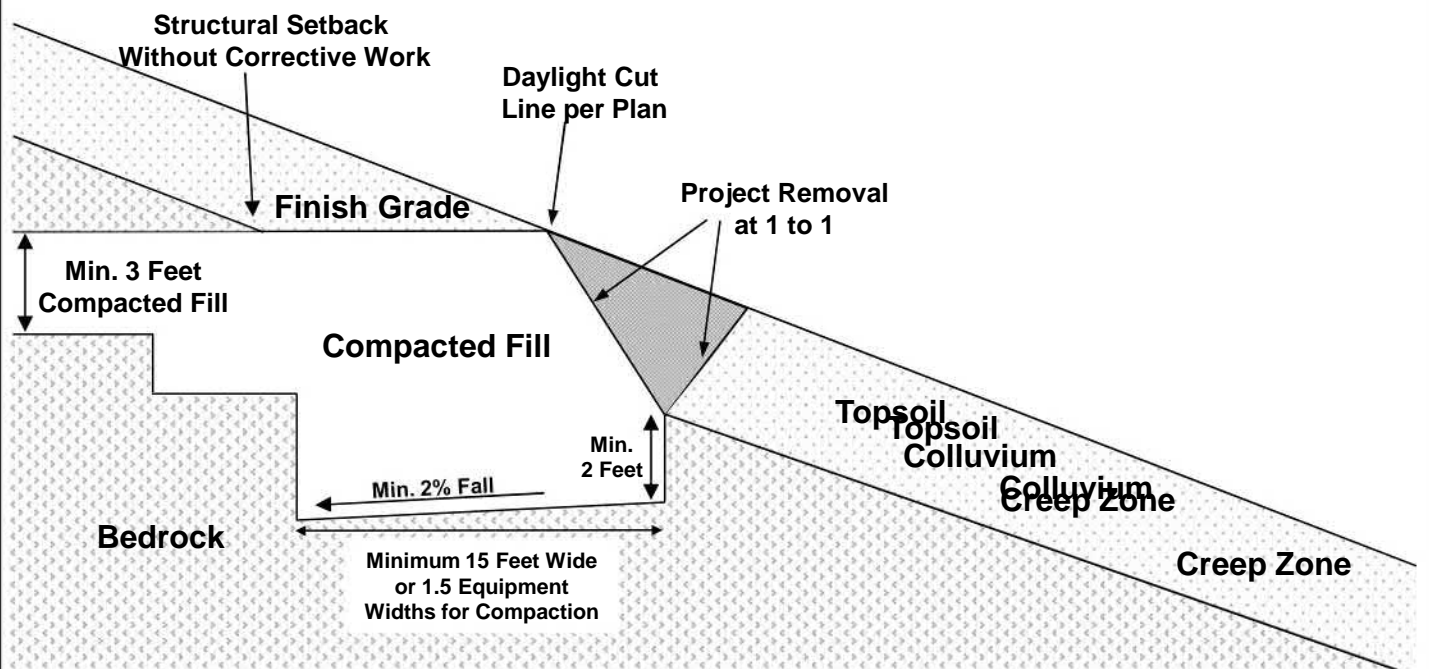

1384 Poinsettia Avenue, Suite A
Vista, California 92081-8505

**TREATMENT ABOVE
NATURAL SLOPES**

**STANDARD GRADING
GUIDELINES**

PLATE G-2

TYPICAL FILL SLOPE OVER CUT SLOPE

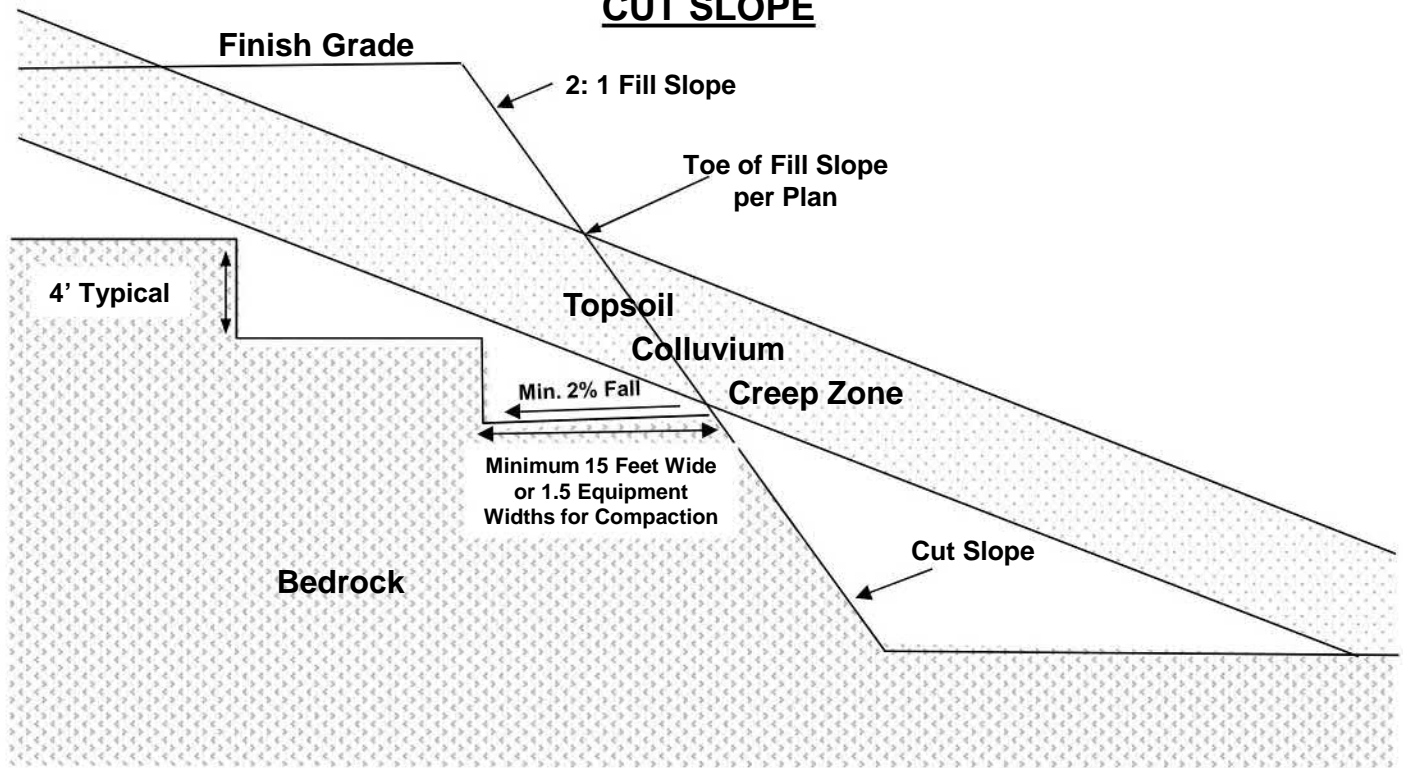

TYPICAL FILL SLOPE

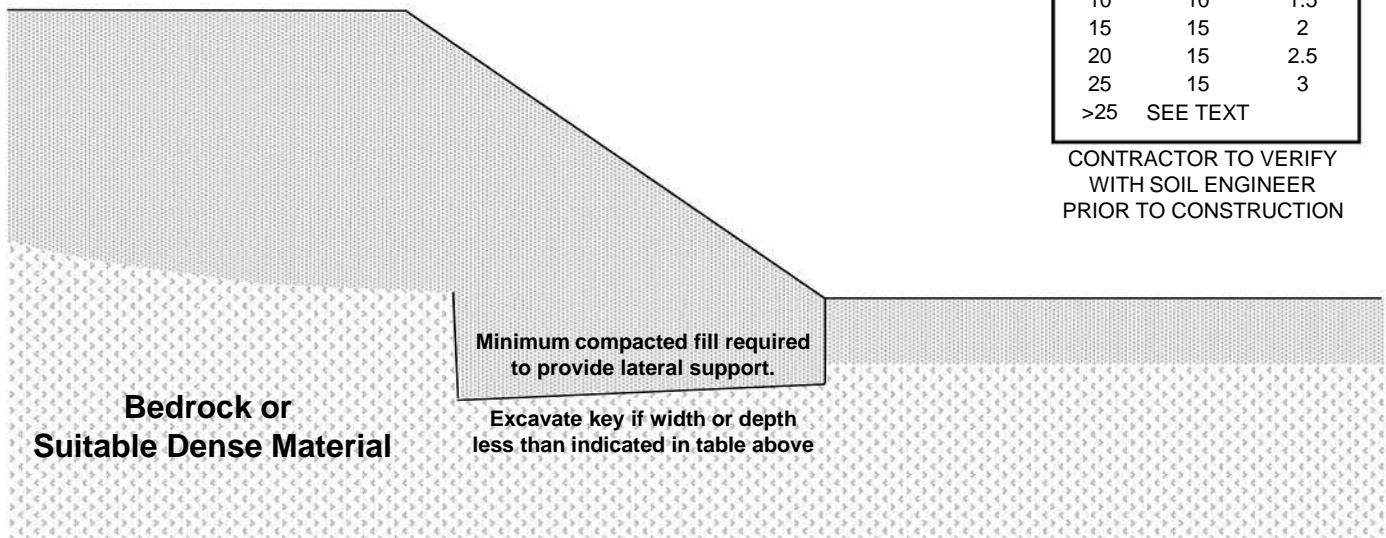

SLOPE HEIGHT	MIN. KEY WIDTH	MIN. KEY DEPTH
5	7	1
10	10	1.5
15	15	2
20	15	2.5
25	15	3
>25	SEE TEXT	

CONTRACTOR TO VERIFY WITH SOIL ENGINEER PRIOR TO CONSTRUCTION



1384 Poinsettia Avenue, Suite A
Vista, California 92081-8505

**COMMON FILL
SLOPE KEYS**

**STANDARD GRADING
GUIDELINES
PLATE G-3**

CROSS SECTIONAL VIEW

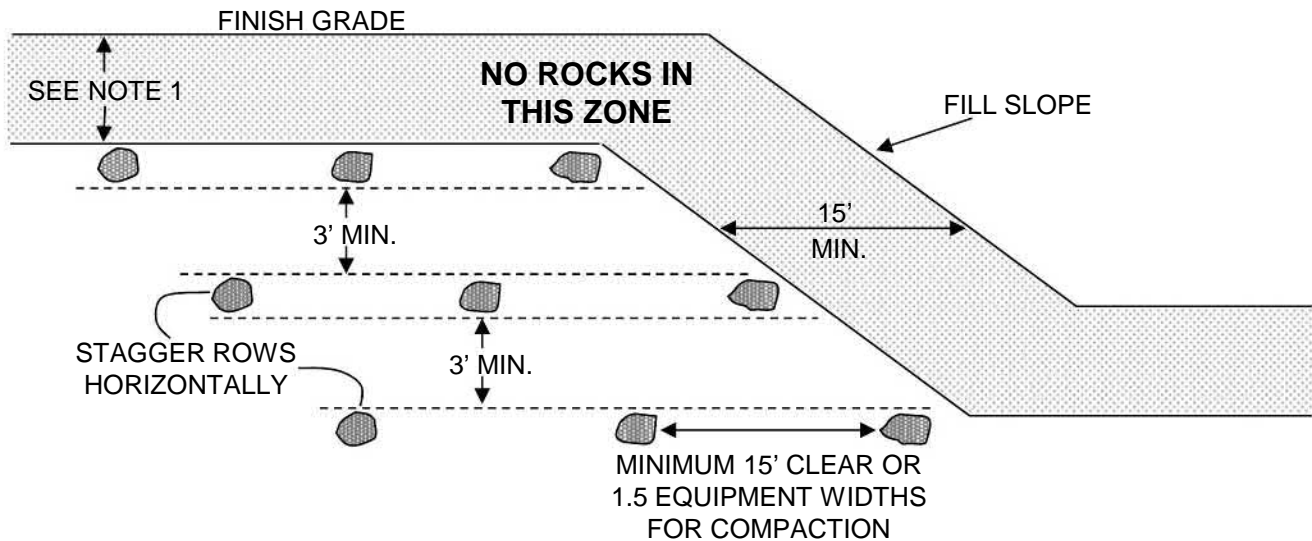

PLAN VIEW

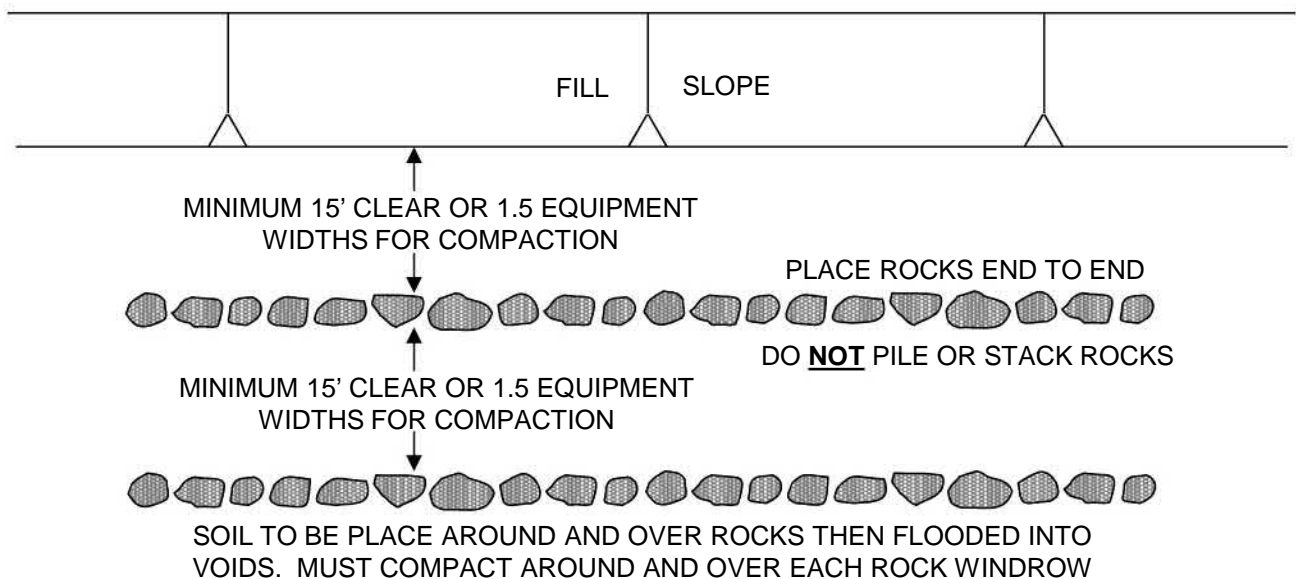

NOTES:

- 1) SOIL FILL OVER WINDROW SHOULD BE 7 FEET OR PER JURISDICTIONAL STANDARDS AND SUFFICIENT FOR FUTURE EXCAVATIONS TO AVOID ROCKS
- 2) MAXIMUM ROCK SIZE IN WINDROWS IS 4 FEET MINIMUM DIAMETER
- 3) SOIL AROUND WINDROWS TO BE SANDY MATERIAL SUBJECT TO SOIL ENGINEER ACCEPTANCE
- 4) SPACING AND CLEARANCES MUST BE SUFFICIENT TO ALLOW FOR PROPER COMPACTION
- 5) INDIVIDUAL LARGE ROCKS MAY BE BURIED IN PITS.



1384 Poinsettia Avenue, Suite A
Vista, California 92081-8505

**ROCK BURIAL
DETAILS**

**STANDARD GRADING
GUIDELINES
PLATE G-4**

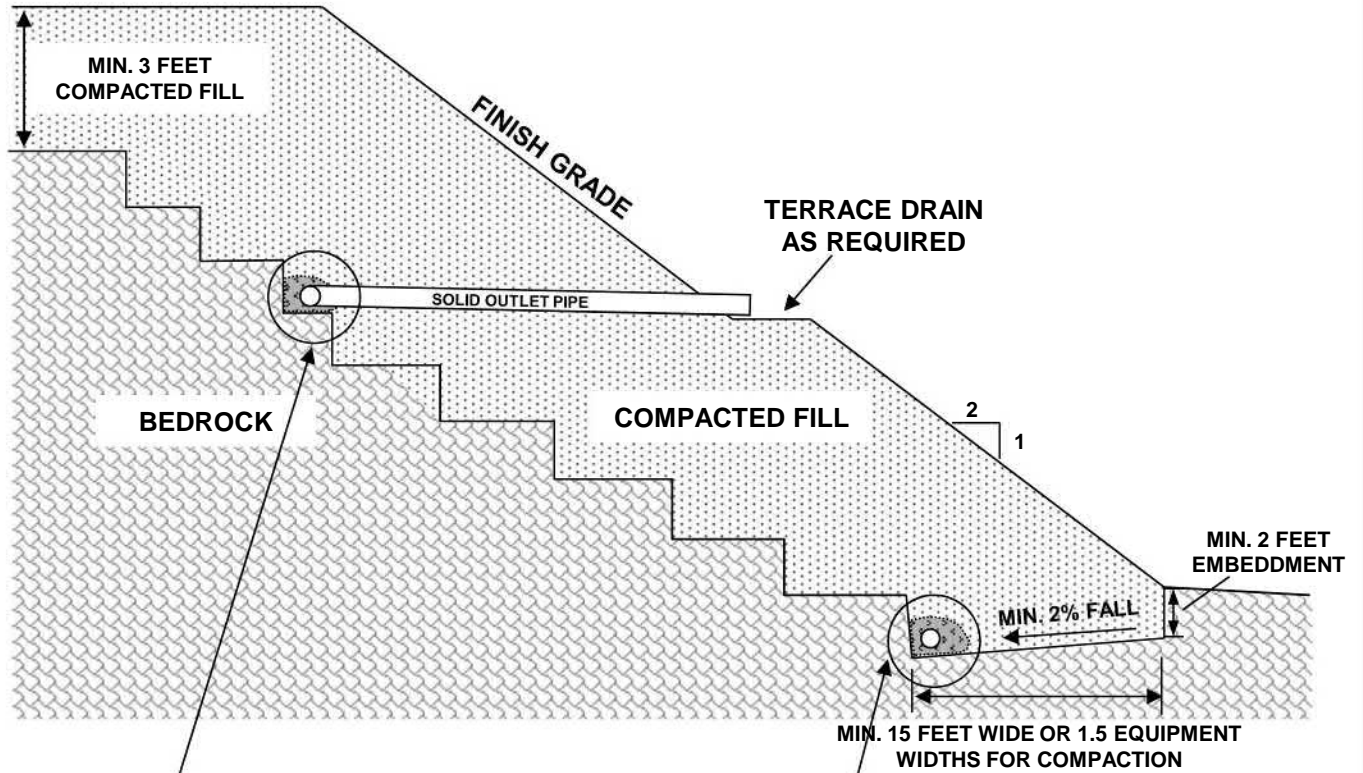

4" or 6" Perforated Pipe in 6 cubic feet per lineal foot clean gravel wrapped in filter fabric outlet pipe to gravity flow at 2% min.

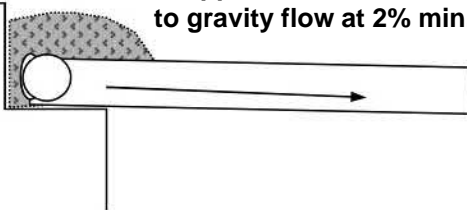

6" Perforated Pipe in 6 cubic feet per lineal foot clean gravel wrapped in filter fabric outlet pipe to gravity flow



1384 Poinsettia Avenue, Suite A
Vista, California 92083

Typical Buttress and Stabilization Fill

PLATE G-5

TRANSITION LOT

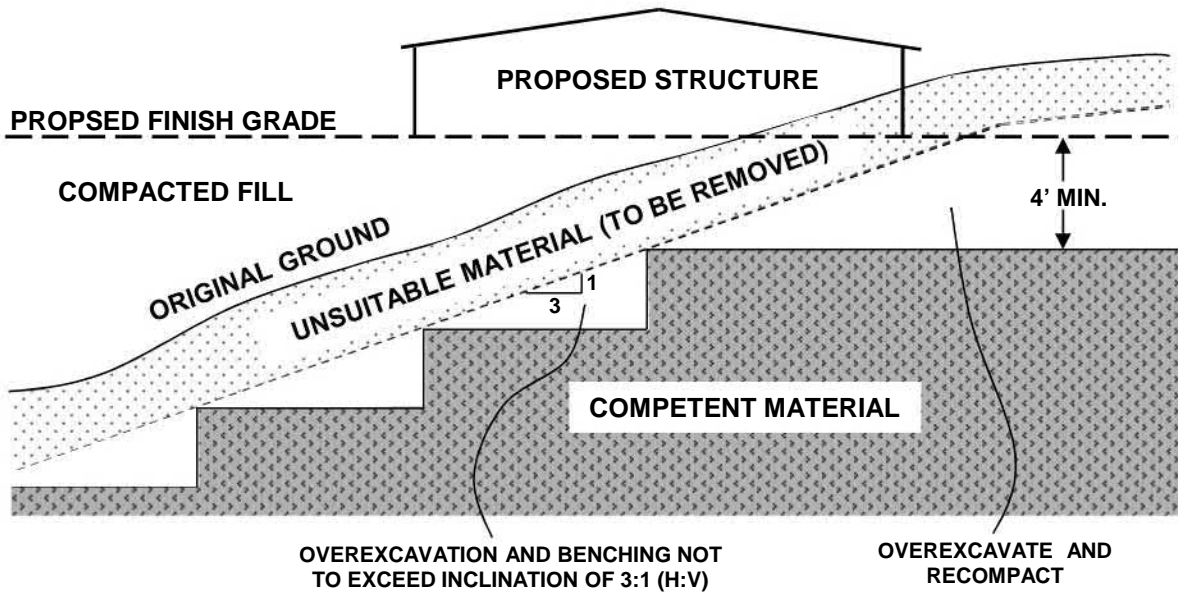

UNDERCUT LOT

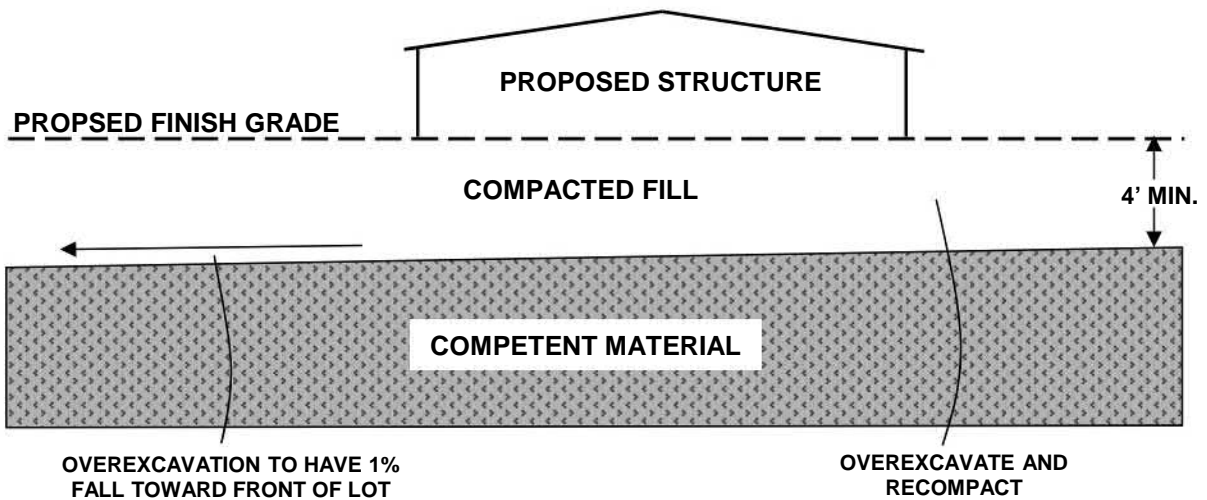

Notes:

1. Removed/overexcavated soils should be recompacted in accordance with recommendations included in the text of the report.
2. Location of cut/fill transition should be verified in the field during site grading.



1384 Poinsettia Avenue, Suite A
Vista, California 92081-8505

**TRANSITION &
UNDERCUT LOTS**

**STANDARD GRADING
GUIDELINES**

PLATE G-6

ATTACHMENT 7
Storm Water Quality Assessment Form

This is the cover sheet for Attachment 7.





City of Oceanside – Engineering Division – Clean Water Program
**STORM WATER QUALITY ASSESSMENT FOR PLANNING,
 ENGINEERING, AND BUILDING PERMIT APPLICATIONS**

All applications for Planning, Engineering, or Building Division permits are required to complete this assessment form and include it as part of the initial permit application submittal. Staff will review the permit application content to determine the applicability of State and City storm water requirements. Please note a storm water assessment cannot be provided without a complete permit application package.

Section 1 – Project Information	
Applicant Name: Sam Dimenstein and Sandra Dimenstein co-trustees of the Dimenstein Family Trust	Phone Number: (888) 357-3553
Project Name: Guajome Lake Road	Project Site Address: Unassigned Guajome Lake Road
Permit Applications Number(s):	Assessor Parcel Number(s): 157-412-15-00
Project Description: Construction of 83 single-family homes	Project Disturbed Area (square feet): 458,900
Existing Impervious Area (square feet): 6,500	Created or Replaced Impervious Area (square feet): 2581,300
Section 2 – Identify Applicable Priority Development Project Categories (Check All Boxes that Apply)	
<input checked="" type="checkbox"/>	New Development Project – A project that creates 10,000 square feet or more of impervious surfaces (collectively over the entire project site). This includes commercial, industrial, residential, mixed-use, and public development projects on public or private land.
<input type="checkbox"/>	Redevelopment Project – A project that creates and/or replaces 5,000 square feet or more of impervious surface (collectively over the entire project site on an existing site of 10,000 square feet or more of impervious surfaces). This includes commercial, industrial, residential, mixed-use, and public development projects on public or private land.
<input type="checkbox"/>	Restaurants – Category is defined as a facility that sells prepared foods and drinks for consumption, including stationary lunch counters and refreshment stands selling prepared foods and drinks for immediate consumption (SIC code 5812); where new or redevelopment projects create and/or replace 5,000 square feet or more impervious surface (collectively over the entire project site).
<input type="checkbox"/>	Hillside Development – Category includes development on any natural slope that is twenty-five percent or greater; where new or redevelopment projects create and/or replace 5,000 square feet or more impervious surface (collectively over the entire project site).
<input type="checkbox"/>	Parking Lots – Category is defined as a land area or facility for the temporary parking or storage of motor vehicles used personally, for business, or for commerce; where new or redevelopment projects create and/or replace 5,000 square feet or more impervious surface (collectively over the entire project site).
<input type="checkbox"/>	Streets, Roads, Highways, Freeways, and Driveways – Category is defined as any paved impervious surface used for the transportation of automobiles, trucks, motorcycles, and other vehicles; where new or redevelopment projects that create and/or replace 5,000 square feet or more impervious surface (collectively over the entire project site).
<input type="checkbox"/>	Water Quality Environmentally Sensitive Area – New or redevelopment projects that create and/or replace 2,500 square feet or more of impervious surface (collectively over the entire project site), and discharge directly to a Water Quality Environmentally Sensitive Area (WQESA). “Discharge directly to” includes flow that is conveyed overland a distance of 200 feet or less from the project to the WQESA, or conveyed in a pipe or open channel any distance as an isolated flow from the project to the ESA (i.e. not commingled with flows from adjacent lands).
<input type="checkbox"/>	Automotive Repair Shop – Category is defined as a facility that is categorized in any one of the following Standard Industrial Classification (SIC) codes: 5013, 5014, 5541, 7532-7534, or 7536-7539, where new or redevelopment projects create and/or replace 5,000 square feet or more impervious surface (collectively over the entire project site).
<input type="checkbox"/>	Retail Gasoline Outlet (RGOs) – Category includes RGOs that meet the following criteria (a) 5,000 square feet or more or (b) a projected Average Daily Traffic (ADT) of 100 or more vehicles per day; where new or redevelopment projects create and/or replace 5,000 square feet or more impervious surface (collectively over the entire project site).
<input checked="" type="checkbox"/>	Development Projects greater than one acre – New or redevelopment projects that result in the disturbance of one or more acres of land and are expected to generate pollutants post construction.



City of Oceanside – Engineering Division – Clean Water Program
**STORM WATER QUALITY ASSESSMENT FOR PLANNING,
 ENGINEERING, AND BUILDING PERMIT APPLICATIONS**

Section 3 – Identify Projects Not Subject to Permanent Stormwater Requirements (Check All Boxes that Apply)	
<input type="checkbox"/>	The project consists of work entirely within an existing structure.
<input type="checkbox"/>	The project consists of construction of overhead or underground utilities (no new impervious surfaces).
<input type="checkbox"/>	The project consists of routine maintenance.
<input type="checkbox"/>	The project consists of less than 50 yards of grading and presents no opportunities to improve water quality.
Section 4 – Project Category Determination	
<input checked="" type="checkbox"/>	Priority Development Project: If any item in Section 2 is applicable, the project is a Priority Development Project. <u>Please prepare a PDP SWQMP for the project.</u>
<input type="checkbox"/>	Standard Development Project: If none of the items in Section 2 or 3 are applicable, the project is a Standard Development Project. <u>Please prepare an SDP SWQMP.</u>
<input type="checkbox"/>	Project Not Subject to Permanent Stormwater Requirements: If any item in Section 3 is applicable, the project is not subject to Permanent Stormwater Requirements. <u>Please submit the project plans with this form.</u> Note: Projects in this category are subject to typical pollution prevention measures outlined by the pollution prevention checklist on the following page.
Section 5 – Applicant Certification	
Name of Responsible Party: Kevin Dunn for: Rincon Homes Inc.	Title: Managing member
Email Address (optional)	Phone Number: (888) 357-3553
I understand and acknowledge the City of Oceanside has adopted minimum requirements, as mandated by the San Diego Regional Water Quality Control Board – Order No. R9-2013-0001, as amended by Order Nos. R9-2015-0001 and R9-2015-0100 (NPDES NO. CAS0109266) for mitigating impacts associated with urban runoff, including storm water from construction and land development activities. I certify this assessment has been accurately completed to the best of my knowledge and is consistent with the proposed project. I acknowledge that non-compliance with the City Best Management Practice (BMP) Design Manual, Grading Ordinance, and Erosion Control Ordinance may result in enforcement action by the City, the California State Water Resources Control Board, and/or the San Diego Regional Water Quality Control Board. Enforcement action may include stop work orders, notice of violation, fines, or other actions.	
Applicant Signature:	Date: 2/21/2022



City of Oceanside – Engineering Division – Clean Water Program
**STORM WATER QUALITY ASSESSMENT FOR PLANNING,
 ENGINEERING, AND BUILDING PERMIT APPLICATIONS**

**Stormwater Pollution Prevention Measures
 for Projects Not Subject to Permanent Stormwater Requirements**

Project Activity	Yes	No	Required Pollution Prevention
Trash & Waste Generation **REQUIRED FOR ALL PROJECTS**	<input type="checkbox"/>	<input type="checkbox"/>	<ul style="list-style-type: none"> • Train/inform all employees of pollution prevention requirements • Collect and contain all construction trash, waste, and debris • Promptly contain and clean any spill on site • Routinely inspect site, remove loose trash and prevent spills • Properly dispose of any hazardous materials • Do not wash down surfaces unless water is collected or directed to landscape • Permanent trash collection areas require full structure/enclosure
Digging of Dirt – excavation, trenching, or grading	<input type="checkbox"/>	<input type="checkbox"/>	<ul style="list-style-type: none"> • Do not allow dirt to migrate into street, sidewalk, or storm drain • Preserve existing vegetation where feasible • Perimeter site controls such as silt fence or straw wattles • Cover exposed dirt using mulch, tarps, or erosion control devices • Install and secure tarps over dirt piles • Routinely sweep site to remove dirt
Landscaping and Irrigation Systems	<input type="checkbox"/>	<input type="checkbox"/>	<ul style="list-style-type: none"> • Do not store landscape materials in street • Do not allow dirt to migrate into street, sidewalk, or storm drain • Test irrigation system and prevent runoff/overspray • Install and secure tarps over piles of mulch or soil • Routinely sweep site to remove mulch or soil • Do not wash down surfaces unless water is collected or directed to landscape
Concrete, Paint, Mortar, or Stucco Work	<input type="checkbox"/>	<input type="checkbox"/>	<ul style="list-style-type: none"> • Contain wet mixing areas within confined area • Do not allow material to travel into site soil, street, or storm drain • Properly dispose of waste material
Temporary Storage of Materials Outside	<input type="checkbox"/>	<input type="checkbox"/>	<ul style="list-style-type: none"> • Elevate material off ground where possible, such as on pallets • Install and secure tarps over materials
Demolition of Structures	<input type="checkbox"/>	<input type="checkbox"/>	<ul style="list-style-type: none"> • Follow Required Pollution Prevention for "Digging of Dirt"
New Structure – house addition, shed, etc.	<input type="checkbox"/>	<input type="checkbox"/>	<ul style="list-style-type: none"> • Follow Required Pollution Prevention for "Digging of Dirt" • Direct downspouts to landscape, where feasible • Consider rainwater harvesting • Preserve existing vegetation and drainage patterns, where feasible
Patio, Driveway, or Sidewalk	<input type="checkbox"/>	<input type="checkbox"/>	<ul style="list-style-type: none"> • Consider use of pervious pavers or pervious concrete (refer to Section 3 of page 4 for routine maintenance information) • Direct runoff to landscape areas, where feasible
Re-Roofing	<input type="checkbox"/>	<input type="checkbox"/>	<ul style="list-style-type: none"> • Contain removed roof debris in waste containers • Follow Required Pollution Prevention for "Temporary Storage of Materials Outside"
Washing of Material, Equipment, or Surface	<input type="checkbox"/>	<input type="checkbox"/>	<ul style="list-style-type: none"> • Do not wash down surfaces unless water is collected or directed to landscape
Draining of Water Heater, Pool, or Spa	<input type="checkbox"/>	<input type="checkbox"/>	<ul style="list-style-type: none"> • Direct drain water to landscape areas where possible • Contact Stormwater Division if considering draining to sanitary system cleanout or storm drain system (760-643-2804)
Storm Drain at Industrial or Commercial Property	<input type="checkbox"/>	<input type="checkbox"/>	<ul style="list-style-type: none"> • Install "No Dumping" or similar signage at each storm drain inlet



City of Oceanside – Engineering Division – Clean Water Program
**STORM WATER QUALITY ASSESSMENT FOR PLANNING,
ENGINEERING, AND BUILDING PERMIT APPLICATIONS**

Completion Guidance

Please note – the Applicant is required to complete and submit this form as part of the project application. For definitions and additional information, please refer to the City of Oceanside BMP Design Manual. For assistance, please contact Development Services Staff at (760) 435-4373.

Section 1 – Project Information

1. Applicant Name – provide name of Individual completing form, i.e. Owner or Owner Representative
2. Phone Number – provide phone number of Individual completing form, i.e. Owner or Owner Representative
3. Project Name – provide project name (consistent with project application)
4. Project Site Address – provide a physical address for the proposed project, or nearest cross street
5. Permit Application Number(s) – provide all applicable permit application numbers
6. Assessor Parcel Number(s) – provide Assessor Parcel Number(s); refer to title documents or contact City Staff for assistance
7. Project Description – provide a brief project description (e.g. single-family dwelling, retail business, repair shop, etc)
8. Project Disturbed Area – provide the disturbed area for the entire project, including onsite and offsite work
9. Existing Impervious Area – provide the total existing impervious area within the property and project boundary
10. Created or Replaced Impervious Area – provide the total area of all newly created or replaced impervious surfaces within the project area

Section 2 – Identify Applicable Priority Development Project Categories

1. Review each category and check the appropriate boxes that apply to your project.
2. General identification of Automotive Repair Shop SIC (Standard Industrial Classifications) as follows:
5013 – Motor vehicle supplies and new parts, 5014 – Tires and tubes, 5541 – Gasoline service stations, 7532 – Top and body repair, and paint shops, 7533 – Auto exhaust system repair shops, 7534 – Tire retreading and repair shops, 7536 – Automotive glass replacement shops, 7537 – Automotive transmission repair shops, 7538 – General automotive repair shops, 7539 – Automotive repair shops-not elsewhere classified
3. Contact Staff for assistance in determining applicability of the Water Quality Environmentally Sensitive Area (WQESA) category

Section 3 – Identify Projects Not Subject to Permanent Stormwater Requirements

1. Please refer to Page 1-6 of the City of Oceanside BMP Design Manual for a complete list of routine maintenance activities.
2. Activities that expose native subgrade in the process of replacing impervious surfaces, are not considered routine maintenance.

Section 4 – Project Category Determination

1. PDP SWQMP – Priority Development Project Stormwater Quality Management Plan
2. SDP SWQMP – Standard Development Project Stormwater Quality Management Plan
3. Contact Staff for assistance in determining the Project Category

Section 5 – Applicant Certification

1. Name of Responsible Party – provide name of Owner
2. Title of Responsible Party – provide responsible party's title, if applicable
3. Phone Number – provide phone number of Owner
4. Email Address (Optional) – provide email address
5. Applicant Signature – provide signature of Individual completing form, i.e. Owner or Owner Representative
6. Date – provide date current date



